

## Commercial 240V Emergency Stop & Electric Timer

Model # 5550-240E

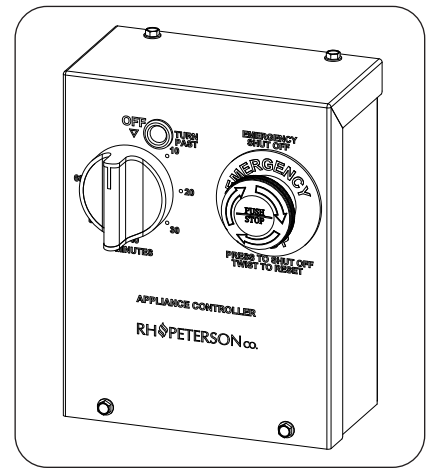

**⚠ WARNING:** For Outdoor Use Only.  
Installation and service must be performed by an NFI  
certified or other qualified professional service technician.

**INSTALLER:** Leave these instructions with consumer.  
**CONSUMER:** Retain for future reference.

### INSTALLATION REQUIREMENTS

**Observe all local codes and ordinances when installing this commercial controller.** If no local codes are applicable, installation MUST be in accordance with the latest National Electric Code, ANSI/NFPA 70, or the Canadian Electrical Code, CSA C22.1, as applicable. Installation must be performed by a qualified professional service technician. Your individual installation may vary.

- Commercial control MUST be installed at a minimum distance of 6 feet away from the appliance that it is easily accessible for electrical connection, maintenance, and service.
- Ensure control is at a minimum height above ground that meets all local codes and is out of reach of children.
- A waterproof, outdoor-rated conduit that meets all local code requirements is required for installation for electrical connections.
- Use any appropriate hardware for your application, provided it complies with all local codes, ordinances, and the National Electrical Code requirements.

### Specifications

- Maximum ambient operating range: from -20° F (-29° C ) to 175° F (79° C)
- Electrical supply must be rated for 230~240VAC (50 AMP maximum)

### Electrical Requirements

**Note:** All electrical components are pre-wired for this outdoor commercial control. Follow the requirements below for electrical installation as necessary for your installation.

**Important:** Electrical setup and installation of this outdoor commercial control MUST be performed by a licensed electrician.

- **TURN OFF THE MAIN ELECTRICAL SUPPLY TO THE INSTALLATION LOCATION.**
- This control must be powered by a dedicated GFCI circuit breaker.
- Electrical supply must be rated for 230~240VAC/ 50 AMP maximum.
- Electrical wiring not supplied; use appropriate size copper conductors only for your application.
- External wiring source can be installed through direct hard-wire or use an approved flexible conduit/cable suitable for outdoor installation.
- **Check that the control device type and rating are suitable for the appliance to be controlled.**

**IMPORTANT:** USE COPPER CONDUCTORS ONLY. DO NOT TIN CONDUCTORS. TAKE CAUTION THAT THERE ARE NO STRAY WIRE STRANDS.

# PRODUCT DIMENSIONS

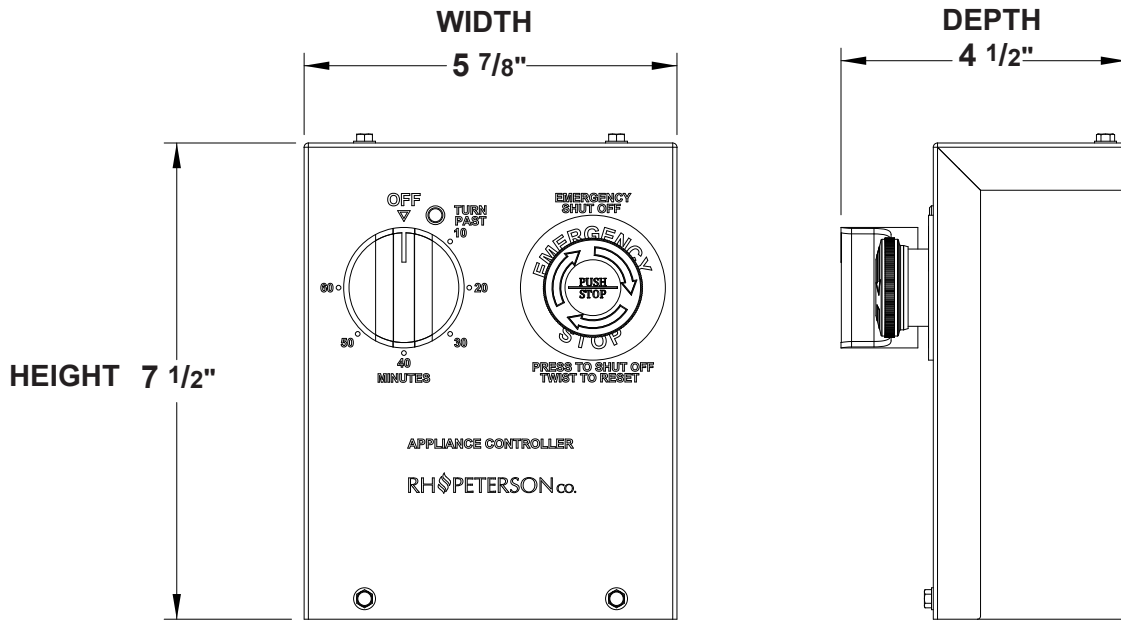

Fig. 2-1 Commercial dimensions

## INSTALLATION OVERVIEW

Follow ALL information found in this manual and in the appliance owner’s manual. Installation must be performed by a licensed professional service technician.

**CAUTION:** Ensure all electrical supply is OFF at the location of installation. The appliance must be completely cool prior to any installation. Observe the National Electric Code (NFPA70) and all local codes.

This control is designed to be mounted externally outdoors onto a wall's stable surface. It must be powered by a dedicated GFCI circuit breaker rated for 230~240VAC (50 AMP maximum). Refer to Fig. 2-2 as a reference for installation. Your installation may vary.

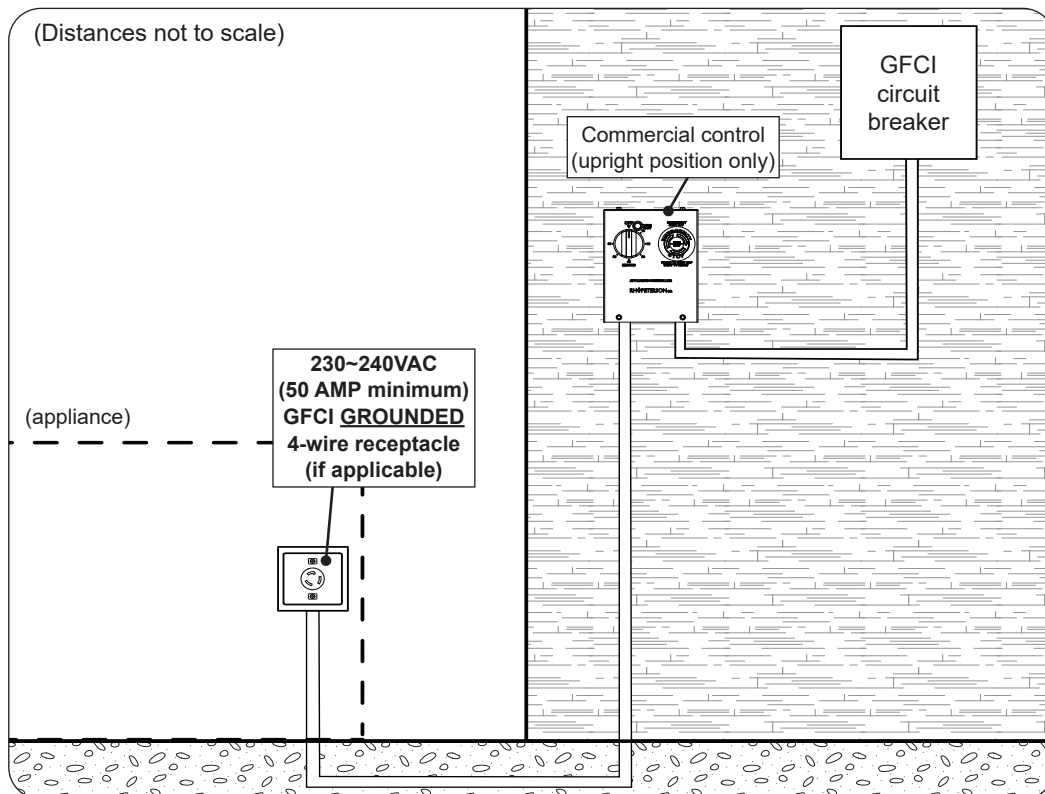

Fig. 2-2 Installation overview

## ELECTRICAL SETUP

**Important:** Electrical setup and installation of this outdoor commercial control MUST be performed by a licensed electrician.

- Verify proper polarity of the commercial control and a dedicated GFCI circuit breaker.
  - **TURN OFF THE MAIN ELECTRICAL SUPPLY TO THE INSTALLATION LOCATION.**
  - External wiring source can be installed through direct hard-wire or use an approved flexible conduit/cable suitable for outdoor installation.
  - Electrical wiring not supplied; use appropriate size copper conductors only for your application.
1. Determine the best location for the control position with a minimum height acceptable by all local codes and a minimum distance of 6 feet away from the intended appliance. The control must be secured in an upright position as shown in INSTALLATION OVERVIEW on the previous page. This needs to be able to supply sufficient voltage between the circuit breaker and the receptacle.
- Note:** The control must be mounted externally on a wall's stable surface. Consider the location of wall studs for mounting or any obstructions when planning for installation.
2. Route electrical supply to the control position as applicable to your installation. Ensure that all code and safety requirements have been met before continuing installation.

## INSTALLATION

1. Unscrew the  $\frac{3}{32}$ " set screw (found on left side of knob stem) then pull out the timer knob and set aside. See Fig. 3-1, A.
2. Using a  $\frac{1}{4}$ " socket driver or wrench, remove the four hex bolts from the top and bottom of the control (Fig. 3-1, B).
3. Pull the face plate outward as shown in Fig. 3-1, C.
4. Take caution to not disconnect any electrical wiring, and allow the face plate to hang gently.
5. Mark four (4) pilot holes with the inner component hex bolt holes as a guide and drill into wall. See Fig. 3-2, D.
6. Before mounting onto wall, apply silicone (not supplied), as shown in Fig. 3-2, E and F, to the back and inside of the control.
7. Use a  $\frac{5}{16}$ " socket driver to securely mount the control onto the wall surface with bolts and washers provided. Using alternate hardware appropriate for your individual installation is permitted.

Continue to next page for electrical connections.

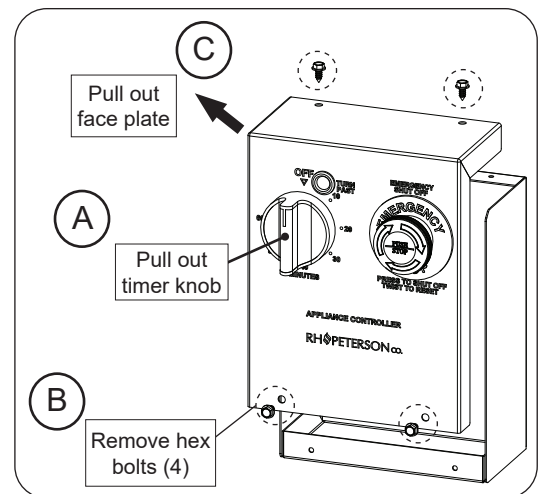

Fig. 3-1 Remove face plate

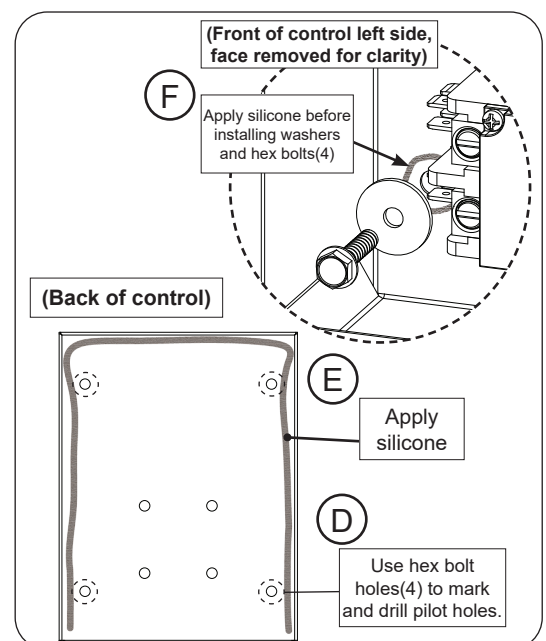

Fig. 3-2 Mount control

## ELECTRICAL CONNECTIONS

1. Route electrical wiring to the control as required for your installation. Use the appropriate knockouts (1/2" or 3/4" trade size) to run wiring to controller. See Fig. 4-1 and the wire diagram on the following page.
2. Make all connections and ensure they are fully secured.
3. Re-install the face plate as shown in Fig. 4-2 and secure into place with hex bolts (4), then reattach the timer knob with its set screw.

**Important:** Avoid overtightening to prevent box damage.

4. Switch ON the electrical system to test the power to the unit.

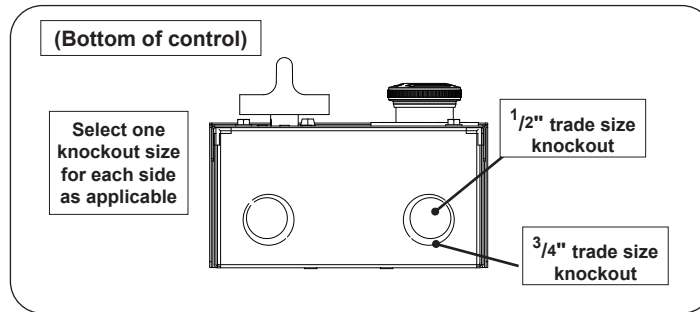

Fig. 4-1 Run electrical wiring

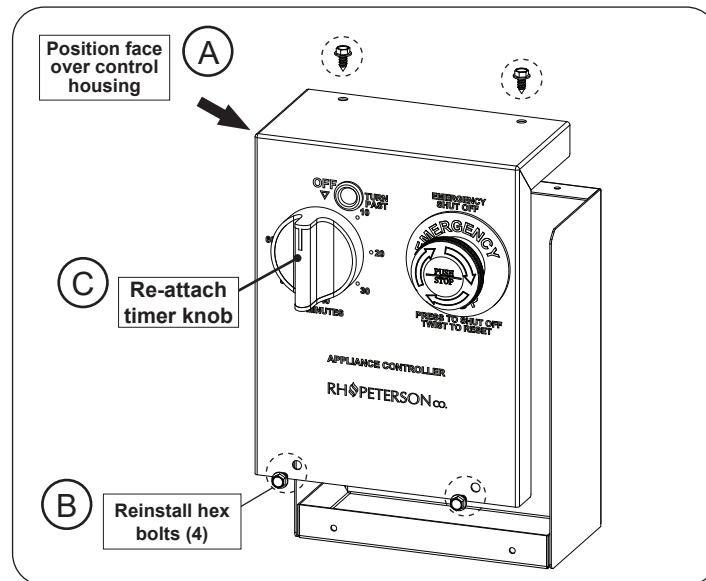

Fig. 4-2 Re-install face plate

Proceed to the following page for wire diagrams.

# COMMERCIAL 240V EMERGENCY STOP & ELECTRIC TIMER WIRE DIAGRAM

## LED indicator wires:

- one wire must be connected to Hot OUT (black wire)
- one wire must be connected to neutral (white wire)

## 3-WIRE HOOK UP

The emergency stop button offers connections to external devices. NC (Normally Closed) is for the control application, while NO (Normally Open) is for optional devices (alarms, lights, etc.) that will activate when button is pressed. See image below.

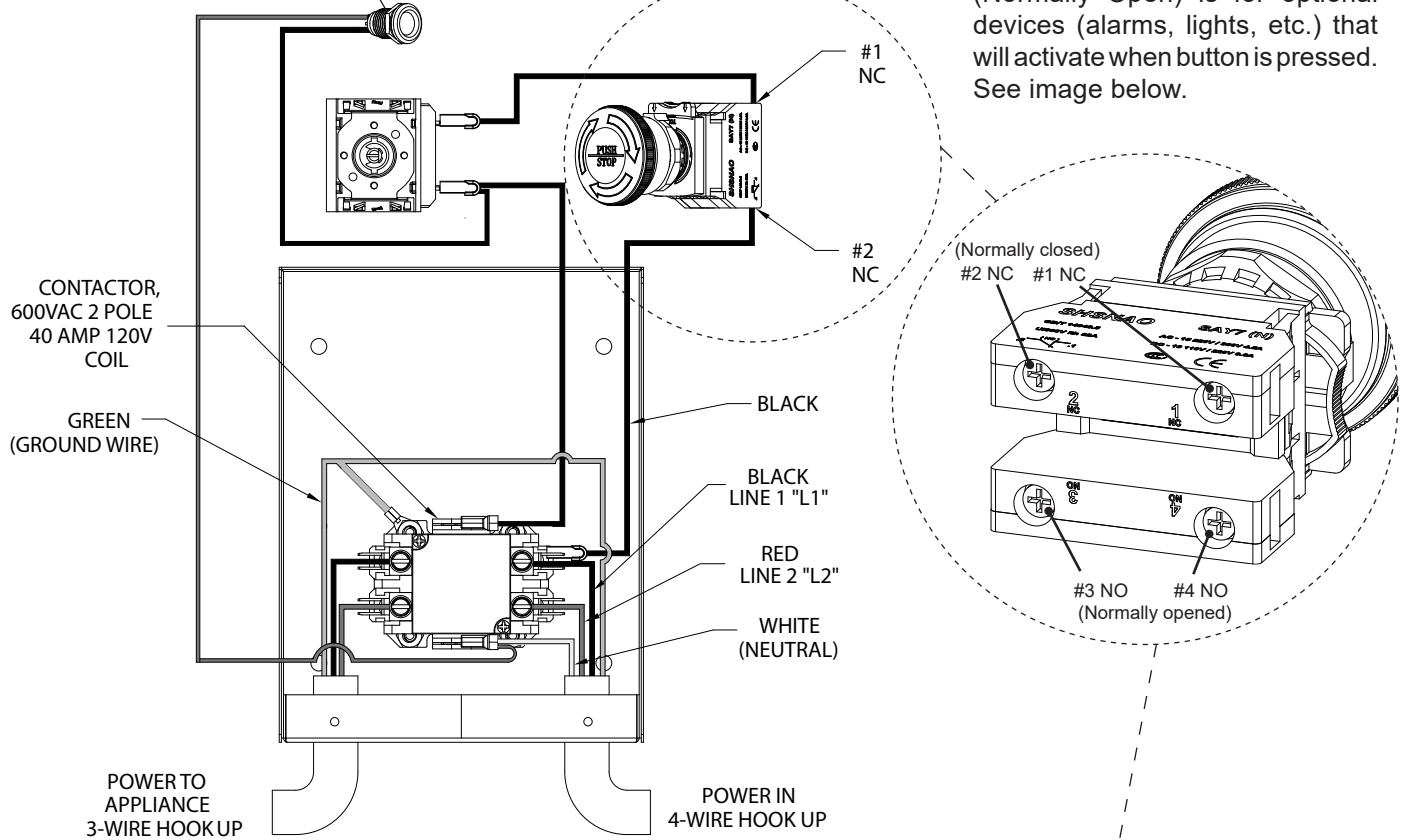

## LED indicator wires:

- one wire must be connected to Hot OUT (black wire)
- one wire must be connected to neutral (white wire)

## 4-WIRE HOOK UP

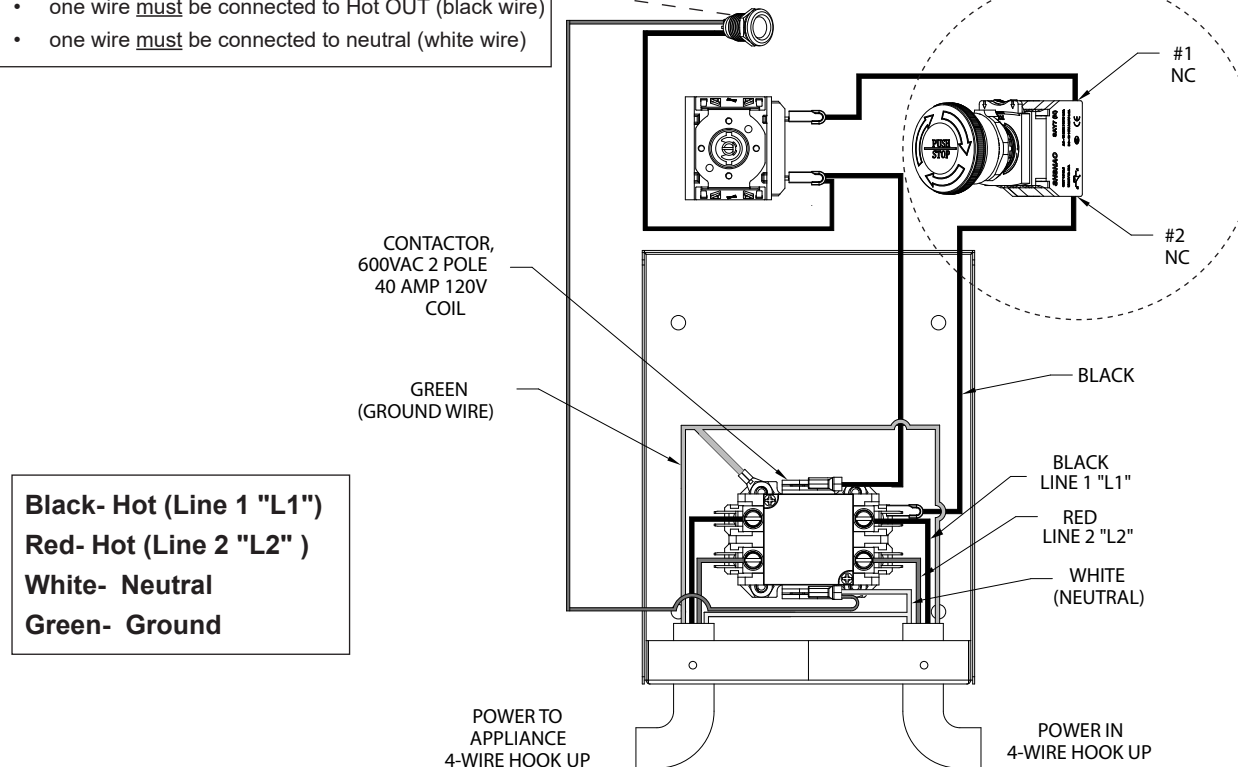

**Black- Hot (Line 1 "L1")**  
**Red- Hot (Line 2 "L2")**  
**White- Neutral**  
**Green- Ground**

## OPERATION

### 1-hr Timer

When activated, the timer will provide power to the appliance for the selected duration of time.

To use, turn the timer knob past 10 minutes ↻ clockwise (to activate timer), then set to desired time. LED indicator light will illuminate indicating power is ON.

To stop the timer and turn off the unit, turn the knob to the OFF position until you hear an audible click. LED indicator light will turn off indicating time has elapsed and power is OFF.

### Emergency Stop

In case of an emergency, press the red emergency stop button to shut the power OFF immediately. Twist the stop button ↻ clockwise to reset the button and restore electrical current to the unit.

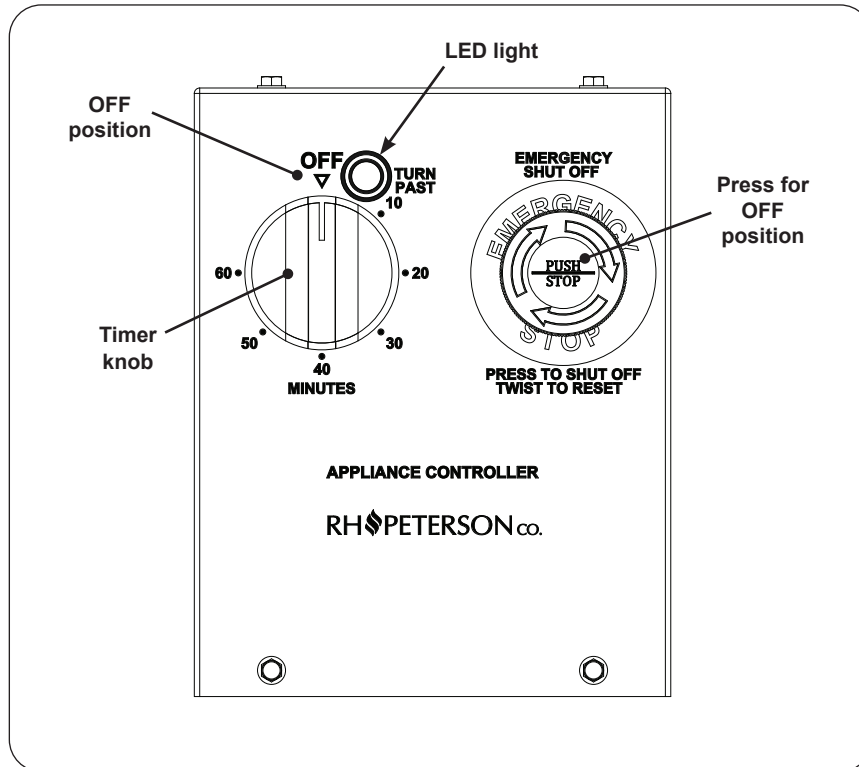

Fig. 6-1 Operation

#### WARNING: AFTER EACH USE:

- ENSURE THAT THE APPLIANCE CONTROLS ARE IN THE OFF POSITION
- IF TIMER IS ON, SLOWLY TURN IT TO THE OFF POSITION

Please use this page to record any information that you may want to have at hand.

# WARRANTY



## COMMERCIAL / MULTI-USER LIMITED WARRANTY

When used in a commercial / multi-user setting\* including but not limited to apartment complexes, multi-family dwelling complexes, schools, hotels, fire stations, police stations, etc.

\*Excluding restaurants and other professional cooking settings.

R.H. Peterson Co. ("RHP") warrants your product to be free from defects in material and workmanship.

RHP Stainless steel housings are warranted for **FIVE (5) YEARS**.

All other components, except batteries, are warranted for **THREE (3) YEARS**.

### A COPY OF YOUR SALES SLIP FOR PROOF OF PURCHASE IS REQUIRED

This warranty applies to the original purchaser for products which are installed in the United States or Canada. This warranty is valid only with proof of purchase, commences on the date of purchase, and terminates (both as to original and any replacement products) on the anniversary date of the original purchase of the product per the above schedules.

This warranty **does not** cover parts which become defective as a result of negligence, misuse, use not in compliance with the Installation and Owner's Manual, accidental damage, improper handling, improper storage, improper installation, **lack of required routine maintenance** (as specified in the Installation and Owner's Manual), or electrical damage. Product must be installed as specified in the Installation and Owner's Manual by a **qualified professional installer**. This warranty **does not** apply to rust, corrosion, oxidation, or discoloration unless the affected part becomes inoperable. RHP products including valves, pilots and controls are designed and certified to be used as a system. Modifications to products which are not specifically authorized will void this warranty and could render the product to be unsafe. Warrantied items will be repaired or replaced at RHP's sole discretion. This warranty **does not** cover labor or labor related charges, except as provided by separate specific written programs from RHP. All repair work must be performed by a qualified professional service person and requires prior approval of RHP.

RHP may require the defective product or part to be returned to the factory to determine the cause of failure. RHP will pay freight charges if the product or part is determined to be defective. This warranty does not cover breakage in shipment from our independent distributor to its customer if the damage is determined to have occurred during that shipment.

This warranty specifically excludes liability for **indirect, incidental, or consequential** damages. Some states and provinces do not allow the exclusion or limitation of incidental or consequential damages, so the above exclusion may not apply to you. This warranty gives you specified legal rights, and you may have other rights that vary from state to state or province.

For additional information regarding this warranty, or to place a warranty claim, contact the RHP dealer where the product was purchased.

When contacting your RHP dealer or the R.H. Peterson Co., please provide the following information:

- Your name, address, telephone number, e-mail
- Sales receipt showing where purchased and date purchased
- Model number, serial number of product, date code
- Relevant information: installer, additions, repairs, when defect was first noted

**TO REGISTER YOUR PRODUCT ONLINE GO TO: [WWW.RHPETERSON.COM](http://WWW.RHPETERSON.COM), AND CLICK ON PRODUCT REGISTRATION. THANK YOU FOR YOUR PURCHASE.**

<b>Quality Check</b>	<b>Date:</b> _____	<b>Model #:</b> _____  <b>Serial #:</b> _____
<b>Electrical Leak Test:</b> _____		
<b>Operation Test:</b> _____		
<b>Inspector:</b> _____		