

GENESIS



SMART
SE-EPX-335
SE-SPX-435

LPG OWNER'S MANUAL



REGISTER TODAY.

We are so glad that you have joined us on the journey to grilling greatness. Register your grill and gain access to fun and engaging WEBER information, including tips, tricks and how to get the most out of your grilling experience.

Keep this Owner's Manual for future reference, thoroughly read through it, and if you have any questions please contact us today.

30644

042022
enASIA

Important Safety Information

DANGER, WARNING, and CAUTION statements are used throughout this Owner's Manual to emphasise critical and important information. Read and follow these statements to help ensure safety and prevent property damage. The statements are defined below.

- ⚠ **DANGER:** Indicates a hazardous situation which, if not avoided, **will result in death or serious injury.**
- ⚠ **WARNING:** Indicates a hazardous situation which, if not avoided, **could result in death or serious injury.**
- ⚠ **CAUTION:** Indicates a hazardous situation which, if not avoided, **could result in minor or moderate injury.**

⚠ DANGER

If you smell gas:

- Shut off gas to the appliance (barbecue).
- Extinguish any open flame.
- Open lid.
- If odour continues, keep away from the appliance (barbecue) and immediately call your gas supplier or the emergency fire services.

⚠ WARNING:

- Do not store or use gasoline or other flammable liquids or vapours in the vicinity of this (barbecue) or any other appliance.
- An LPG cylinder not connected for use shall not be stored in the vicinity of this (barbecue) or any other appliance.

USE OUTDOORS ONLY.

READ THE INSTRUCTIONS BEFORE USING THE APPLIANCE (BARBECUE).

NOTICE TO INSTALLER: These instructions must be left with the consumer.

NOTICE TO CONSUMER: Retain these instructions for future reference.

Installation and Assembly

- ⚠ **DANGER:** This barbecue is not intended to be installed in or on recreational vehicles or boats.
- ⚠ **WARNING:** Do not use this barbecue unless all parts are in place and the barbecue was properly assembled according to the assembly instructions.
- ⚠ **WARNING:** Do not build this model of barbecue in any built-in or slide-in construction.
- ⚠ **WARNING:** Do not modify the appliance. **LPG is not natural gas. The conversion or attempted use of natural gas in an LPG gas unit or LPG gas in a natural gas unit is unsafe and will void your warranty.**
 - Any parts sealed by the manufacturer must not be altered by the user.

Operation

- ⚠ **DANGER:** Only use the barbecue outdoors in a well-ventilated area. Do not use in a garage, building, breezeway, tent, any other enclosed area, or beneath an overhead combustible structure.
- ⚠ **DANGER:** Do not use the barbecue in any vehicle or in any storage or cargo area of any vehicle. This includes, but is not limited to, cars, trucks, station wagons, mini-vans, sport utility vehicles, recreational vehicles, and boats.
- ⚠ **DANGER:** When in use, combustible materials should not be within 61 cm (24 inches) of the back or sides of the barbecue.
- ⚠ **DANGER:** Keep the cooking area clear of flammable vapours and liquids such as petrol, alcohol, etc., and combustible materials.
- ⚠ **DANGER:** This appliance must be kept away from flammable materials during use.
- ⚠ **DANGER:** Do not put a barbecue cover or anything flammable on, or in the storage area under the barbecue while it is in operation or is hot.
- ⚠ **DANGER:** Should a grease fire occur, turn off all burners and leave lid closed until fire is out.
- ⚠ **WARNING:** Accessible parts may be very hot. Keep young children away.
- ⚠ **WARNING:** The use of alcohol, prescription drugs, non-prescription drugs, or illegal drugs may impair the consumer's ability to properly and safely assemble, move, store, or operate the barbecue.
- ⚠ **WARNING:** Never leave the barbecue unattended during pre-heating or use. Exercise caution when using this barbecue. The entire cookbox gets hot when in use.
- ⚠ **WARNING:** Use heat-resistant barbecue mitts or gloves (conforming to EN 407, Contact Heat rating level 2 or greater) when operating barbecue.
- ⚠ **WARNING:** Do not move the appliance during use.
- ⚠ **WARNING:** Keep any electrical supply cord and the fuel supply hose away from any heated surfaces.
- ⚠ **CAUTION:** This product has been safety-tested and is only certified for use in a specific country. Refer to country designation located on outside of box.
- Do not use charcoal, briquettes or lava rock in the barbecue.

Storage and/or Nonuse

- ⚠ **WARNING:** Turn off the gas supply at the gas cylinder after use.
- ⚠ **WARNING:** LPG cylinders must be stored outdoors out of the reach of children and must not be stored in a building, garage or any other enclosed space.
- ⚠ **WARNING:** After a period of storage and/or nonuse, the barbecue should be checked for gas leaks and burner obstructions before use.
- Storage of the barbecue indoors is permissible only if the LPG cylinder is disconnected and removed from the barbecue.

Electrical Supply

- ⚠ **WARNING:** This appliance is not intended for use by persons (including children) with reduced physical, sensory or mental capabilities, or lack of experience and knowledge, unless they have been given supervision or instruction concerning use of the appliance by a person responsible for their safety.
- ⚠ **WARNING:** Children should be supervised to ensure that they do not play with the appliance.
- ⚠ **WARNING:** Only use the power supply unit provided with this appliance.
- ⚠ **WARNING:** This appliance incorporates an earth connection for functional purposes only.
- ⚠ **WARNING:** To protect against risk of electric shock, do not immerse cord or plugs in water or other liquid.
- ⚠ **WARNING:** Unplug from outlet when not in use and before cleaning. Allow to cool before putting on or taking off parts.
- ⚠ **WARNING:** Do not operate any outdoor cooking gas appliance with a damaged cord, plug, or after the appliance malfunctions or has been damaged in any manner. Contact the Customer Service Representative in your area using the contact information on our web site. Log onto www.weber.com.
- ⚠ **WARNING:** Do not let the cord hang over the edge of a table or touch hot surfaces.
- ⚠ **WARNING:** Do not use an outdoor cooking gas appliance for purposes other than intended.
- ⚠ **WARNING:** When connecting, first connect the plug to the outdoor cooking gas appliance then plug appliance into the outlet.
- ⚠ **WARNING:** Use only a Ground Fault Interrupter (GFI) protected circuit with this outdoor cooking gas appliance.
- ⚠ **WARNING:** Never remove the grounding plug or use with an adapter of 2 prongs.
- ⚠ **WARNING:** Use only extension cords with a 3 prong grounding plug, rated for the power of the equipment, and approved for outdoor use with a W-A marking.
- Do not connect two or more extension cords together.

HELLO!

We are so glad that you have joined us on the journey to grilling happiness. Please take some time to read through this Owner's Manual to ensure that you are up and grilling quickly and easily. We want to be with you for the life of your grill, so please take just a couple of minutes to register your grill. When you sign up for a WEBER-ID as part of your registration, we will deliver special grill-related content just for you to enjoy.

So, come along and join us online, on your smart device or however else you'd like to stay in touch.

Thank you for choosing WEBER. We are happy you are here.



Even your grill can update its status

1 DOWNLOAD THE FREE APP



3 CONNECT AND MONITOR

2 INSERT PROBE

4 PERFECT RESULTS

FEATURE	BENEFIT
REMOTE GRILL MONITOR	WI-FI AND BLUETOOTH® GRILL MONITORING Remote grilling access gives you the freedom to walk away and monitor the heat from your smart device.
STEP-BY-STEP GRILLING	PERFECTLY GRILLED FOOD Know when it's time to flip, rest, and serve directly from your smart device. Receive notifications on everything from when it's time to flip food, to a countdown that displays when it's ready.
APP ENABLED FOOD THERMOMETERS	INSTANT FOOD STATUS READOUT View food temperature & doneness without lifting the lid. The food probes monitor doneness from beginning to end and will notify you via the app when it's time to flip, rest, and serve.
RECIPES & INSTRUCTION	WEBER RECIPES AND COOK PROGRAMS Weber recipes and cook programs that provide real time, step-by-step grilling instructions specific to your cook preference and cut of meat.
LED DISPLAY	DASHBOARD The LED display dashboard on your module is where you can visually check temperatures, receive notifications, view connectivity status, and check the status of your cook.



TABLE OF CONTENTS

- 2 Welcome to Weber
 - Important Safety Information
- 4 The Weber Promise
- 5 Product Features
 - GENESIS Smart Features
 - High Performance Grilling
- 6 Getting Started
 - Important Information about LP Gas & Gas Connections
 - Installing the LPG Cylinder
 - Connecting the LPG Cylinder and Leak Checking
- 14 Operation
 - The Very First Time You Grill
 - Every Time You Grill
 - Igniting the Grill
 - Using the sear zone
 - Igniting the Side Burner
 - Integrated WEBER CONNECT Technology
 - Using the WEBER CONNECT Module
 - Food Temperature Probe Care
- 20 Tips and Hints
 - The Flame - Direct or Indirect
 - Discover What's Possible
 - Grilling Do's and Don'ts
 - Real Smoke Flavor
 - Extra on the Side
 - More Cooking Space
 - Grilling at Night
- 24 Product Care
 - Cleaning and Maintenance
- 26 Troubleshooting
- 32 Grilling Guide
- 33 Replacement Parts

The WEBER Promise

At WEBER, we pride ourselves on two things: making barbecues that last and providing a lifetime of excellent customer service.

Thank you for purchasing a WEBER product. Weber-Stephen Products LLC, 1415 S. Roselle Road, Palatine, Illinois 60067 ("WEBER") prides itself on delivering a safe, durable, and reliable product.

This is WEBER's Voluntary Warranty provided to you at no extra charge. It contains the information you will need to have your WEBER product repaired in the unlikely event of a failure or defect.

Pursuant to applicable PRC laws, the Owner has several rights in case the product is defective. Those rights may include repair, replacement, or refund of the defective product, as appropriate depending on the actual circumstance. Those rights include supplementary performance or replacement, abatement of the purchasing price, and compensation. In the European Union, for example, this would be a two-year statutory warranty starting on the date of the handover of the product. These and other statutory rights remain unaffected by this warranty provision. In fact, this warranty grants additional rights to the Owner that are independent from statutory warranty provisions.

WEBER'S VOLUNTARY WARRANTY

WEBER warrants, to the purchaser of the WEBER product (or in the case of a gift or promotional situation, the person for whom it was purchased as a gift or promotional item), that the WEBER product is free from defects in material and workmanship for the period(s) of time specified below when assembled and operated in accordance with the accompanying Owner's Manual. Note: If you lose or misplace your WEBER Owner's Manual, a replacement is available online at www.weber.com, or such country-specific website to which Owner may be redirected.) Under normal, private single family home or flat use and maintenance, Weber agrees within the framework of this warranty to repair or replace defective parts within the applicable time periods, limitations and exclusions listed below. **TO THE EXTENT ALLOWABLE BY APPLICABLE LAW, THIS WARRANTY IS EXTENDED ONLY TO THE ORIGINAL PURCHASER WHO HAS PURCHASED WEBER PRODUCT FROM WEBER'S AUTHORIZED DEALERS AND RETAILERS AND IS NOT TRANSFERABLE TO SUBSEQUENT OWNERS, EXCEPT IN THE CASE OF GIFTS AND PROMOTIONAL ITEMS AS NOTED ABOVE.**

OWNER'S RESPONSIBILITIES UNDER THIS WARRANTY

To ensure trouble-free warranty coverage, it is important (but it is not required) that you register your Weber product online at www.weber.com or such country-specific website to which you may be redirected. Please also retain your original sales receipt and/or invoice. Registering your WEBER product confirms your warranty coverage and provides a direct link between you and WEBER in case we need to contact you.

The above warranty only applies if the Owner takes reasonable care of the WEBER product by following all assembly instructions, usage instructions, and preventative maintenance as outlined in the accompanying Owner's Manual, unless the Owner can prove that the defect or failure is independent of non-compliance with the above-mentioned obligations. If you live in a coastal area, or have your product located near a pool, maintenance includes regular washing and rinsing of the exterior surfaces as outlined in the accompanying Owner's Manual.

WARRANTY HANDLING / EXCLUSION OF WARRANTY

If you believe that you have a part which is covered by this Warranty, please contact WEBER Customer Service using the contact information on our website (www.weber.com, or such country-specific website to which Owner may be redirected). WEBER will, upon investigation, repair or replace (at its option) a defective part that is covered by this Warranty. In the event that repair or replacement are not possible, Weber may choose (at its option) to replace the barbecue in question with a new barbecue of equal or greater value. WEBER may ask you to return parts for inspection, shipping charges to be pre-paid.

This WARRANTY lapses if there are damages, deteriorations, discolourations, and/or rust for which WEBER is not responsible caused by:

- Abuse, misuse, alteration, modification, misapplication, vandalism, neglect, improper assembly or installation, and failure to properly perform normal and routine maintenance;
- Insects (such as spiders) and rodents (such as squirrels), including but not limited to damage to burner tubes and/or gas hoses;
- Exposure to salt air and/or chlorine sources such as swimming pools and hot tubs/spas;
- Severe weather conditions such as hail, hurricanes, earthquakes, tsunamis or surges, tornadoes or severe storms.

The use and/or installation of parts on your WEBER product that are not genuine WEBER parts will void this Warranty, and any damages that result hereby are not covered by this Warranty. Any conversion of a gas barbecue not authorised by WEBER and not performed by a WEBER authorised service technician will void this Warranty.

PRODUCT WARRANTY PERIODS

Cookbox:

12 years, no rust through/burn through
(2 years paint excluding fading or discolouration)

Lid assembly:

12 years, no rust through/burn through
(2 years paint excluding fading or discolouration)

Stainless steel burner tubes:

10 years, no rust through/burn through

Stainless steel cooking grates:

10 years, no rust through/burn through

Stainless steel FLAVORIZER BARS:

10 years, no rust through/burn through

Porcelain-enamelled cast iron cooking grates:

10 years, no rust through/burn through

WEBER CONNECT Components:

3 years

All remaining parts:

5 years

Warranty period commences from the date of sales receipt or invoice. You will be required to present the original sales receipt or invoice in claiming the warranty.

DISCLAIMERS

APART FROM THE WARRANTY AND DISCLAIMERS AS DESCRIBED IN THIS WARRANTY STATEMENT, THERE ARE EXPLICITLY NO FURTHER WARRANTY OR VOLUNTARY DECLARATIONS OF LIABILITY GIVEN HERE WHICH GO BEYOND THE STATUTORY LIABILITY APPLYING TO WEBER. **THE PRESENT WARRANTY STATEMENT ALSO DOES NOT LIMIT OR EXCLUDE SITUATIONS OR CLAIMS WHERE WEBER HAS MANDATORY LIABILITY AS PRESCRIBED BY STATUTE.**

NO WARRANTIES SHALL APPLY AFTER THE APPLICABLE PERIODS OF THIS WARRANTY. NO OTHER WARRANTIES GIVEN BY ANY PERSON, INCLUDING A DEALER OR RETAILER, WITH RESPECT TO ANY PRODUCT (SUCH AS ANY "EXTENDED WARRANTIES"), SHALL BIND WEBER. THE EXCLUSIVE REMEDY OF THIS WARRANTY IS REPAIR OR REPLACEMENT OF THE PART OR PRODUCT UNLESS OTHERWISE MANDATORILY REQUIRED BY APPLICABLE LAW.

IN NO EVENT UNDER THIS VOLUNTARY WARRANTY SHALL RECOVERY OF ANY KIND BE GREATER THAN THE AMOUNT OF THE PURCHASE PRICE OF THE WEBER PRODUCT SOLD.

YOU ASSUME THE RISK AND LIABILITY FOR LOSS, DAMAGE, OR INJURY TO YOU AND YOUR PROPERTY AND/OR TO OTHERS AND THEIR PROPERTY ARISING OUT OF THE MISUSE OR ABUSE OF THE PRODUCT OR FAILURE TO FOLLOW INSTRUCTIONS PROVIDED BY WEBER IN THE ACCOMPANYING OWNER'S MANUAL.

PARTS AND ACCESSORIES REPLACED UNDER THIS WARRANTY ARE WARRANTED ONLY FOR THE BALANCE OF THE ABOVE MENTIONED ORIGINAL WARRANTY PERIOD(S).

THIS WARRANTY APPLIES TO PRIVATE SINGLE FAMILY HOME OR FLAT USE ONLY AND DOES NOT APPLY TO WEBER BARBECUES USED IN COMMERCIAL, COMMUNAL OR MULTI-UNIT SETTINGS SUCH AS RESTAURANTS, HOTELS, RESORTS, OR RENTAL PROPERTIES.

WEBER MAY FROM TIME TO TIME CHANGE THE DESIGN OF ITS PRODUCTS. NOTHING CONTAINED IN THIS WARRANTY SHALL BE CONSTRUED AS OBLIGATING WEBER TO INCORPORATE SUCH DESIGN CHANGES INTO PREVIOUSLY MANUFACTURED PRODUCTS, NOR SHALL SUCH CHANGES BE CONSTRUED AS AN ADMISSION THAT PREVIOUS DESIGNS WERE DEFECTIVE.

Refer to International Business Units list at the end of this Owner's Manual for additional contact information.



PROTECT YOUR INVESTMENT

Shield your grill from the elements with a heavy-duty premium grill cover.

GENESIS Smart FEATURES

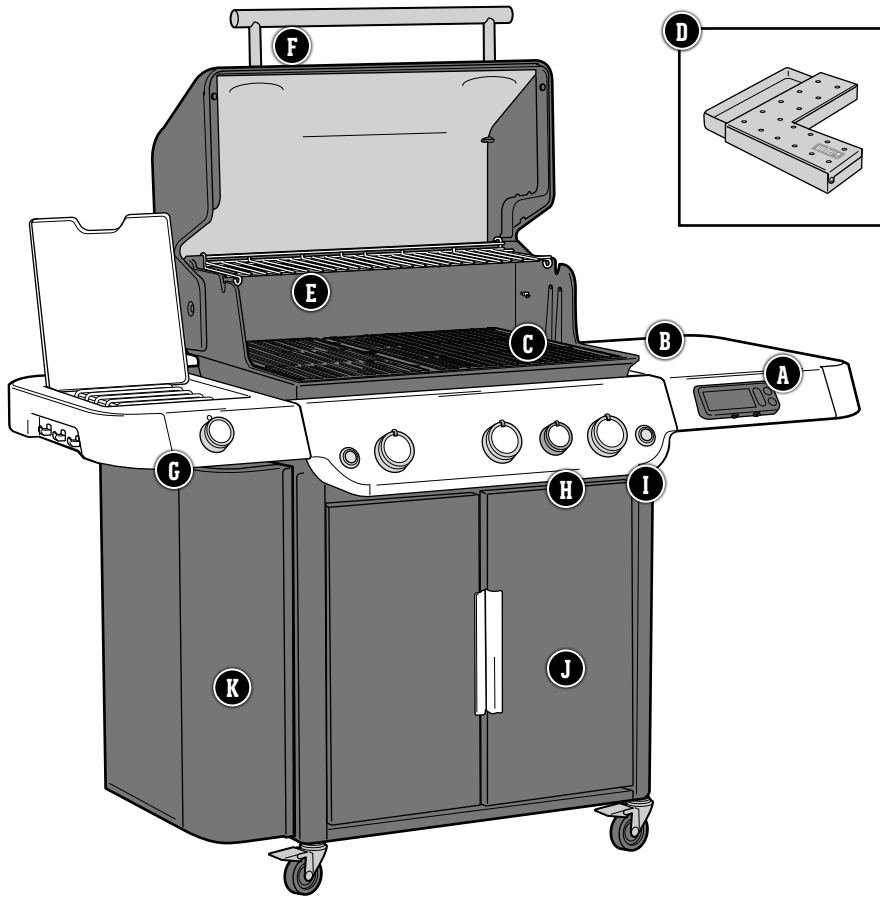

A WEBER CONNECT

Confidently tend to the grill and your guests while using the integrated WEBER CONNECT technology. This device monitors internal grill temperature and uses food temperature probes allowing you to monitor the temperature of your food. You can also monitor your grill from your smart device with the WEBER CONNECT app via Bluetooth® or Wi-Fi connection.

One food temperature probe is included. Additional food probes are sold separately.

B Prep & Serve Table

Use the side tables to keep platters, seasonings, and tools within arm's reach. Hang your essential grilling tools on the hooks for easy access and organization of your backyard workspace.

C WEBER CRAFTED Outdoor Kitchen Collection Cooking Grates and Frame

Your grill is Outdoor Kitchen Collection Ready with the included cooking grates and frame. Additional WEBER CRAFTED grillware sold separately. (Premium stainless steel cooking grates available on SE models only)

D Genesis Smoker Box

Positioned beneath the cooking grates, the smoker box adds continuous smoke to your cook. (SE models only)

E Expandable Top Cooking Grate

Keeps food warm, or toasts buns, while the main course finishes grilling on the grate. Fold it out when you need a secondary cooking surface.

F Grill Lighting

Integrated with the lid handle, LED lights illuminate the cooking surface to keep grilling as the sun goes down. (SE and Premium models only)

G Side Burner

Use the side burner to simmer BBQ sauce or sauté veggies while the main course grills under the lid.

H Sear zone

The sear zone is designed to create an intense heat zone to quickly add sear marks to your meat.

I Lighted Control Knobs

With a push of a button, the control knobs light up to offer optimal control while night-time grilling. (Premium models only)

J Grill Cabinet

The grill cabinet adds enclosed storage space for all of your essential grilling tools and accessories.

K WEBER CRAFTED Grill Locker

Convenient side storage makes it easy to access all of your WEBER CRAFTED grillware.

Some features listed are only available on select models.

HIGH PERFORMANCE GRILLING

The high performance grilling system sets the standard in the world of gas grilling, and lands Weber in a class of its own. This powerful grilling system is based on over 65 years of grilling experience, culinary expertise, and most importantly, the wants and needs of the people who matter most – our grilling community. Each component was uniquely designed for ease-of-use and to provide an unequalled satisfaction to your backyard grilling experience.

1 INFINITY Ignition



The Infinity Ignition is guaranteed to ignite. Rest assured that you'll be up-and-grilling the first time, every time.

2 Burners

The unique, tapered shape delivers a consistent gas flow from front to back. This provides ultimate heat distribution, ensuring that food grills evenly and consistently anywhere on the cooking grates.

3 FLAVORIZER BARS

Stainless Steel FLAVORIZER BARS are angled just right to catch drippings that smoke and sizzle, adding that irresistible smoky flavor that we all know and love to your food.

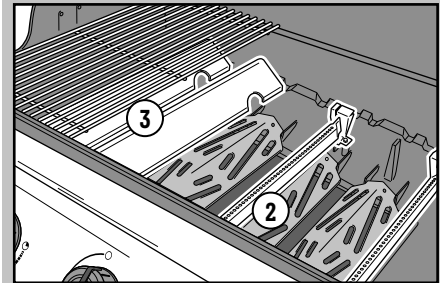

4 Grease Management System

Drippings that are not vaporized by the FLAVORIZER BARS are funneled away from the burners into the disposable drip tray, located within the removable catch pan under the cookbox. Simply remove the catch pan and replace the drip tray as needed.

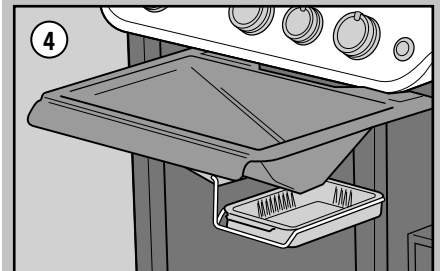

The grills illustrated in this Owner's Manual may vary slightly from the model purchased.

Important Information about LP Gas & Gas Connections

What is LPG?

Liquefied petroleum gas, also called LPG or LP gas, is the flammable, petroleum-based product used to fuel your barbecue. It is a gas at moderate temperatures and pressure when it is not contained. But at moderate pressure inside a container, such as a cylinder, LPG is a liquid. As pressure is released from the cylinder, the liquid readily vaporises and becomes gas.

Safe Handling Tips for LPG Cylinders

- A dented or rusty LPG cylinder may be hazardous and should be checked by your LP gas supplier. Do not use a cylinder with a damaged valve.
- Although your LPG cylinder may appear to be empty, gas may still be present, and the cylinder should be transported and stored accordingly.
- The LPG cylinder must be installed, transported, and stored in an upright, secure position. Cylinders should not be dropped or handled roughly.
- Never store or transport the LPG cylinder where temperatures can reach 50°C (125°F) (the cylinder will become too hot to hold by hand).

LPG Cylinder Requirements

- Use cylinders with a minimum capacity of 3 kg and a maximum capacity of 13 kg.

What is a Regulator?

Your gas barbecue is equipped with a pressure regulator, which is a device to control and maintain uniform gas pressure as gas is released from the LPG cylinder.

Regulator and Hose Requirements

- In Great Britain, this barbecue must be fitted with a regulator complying with BS 3016, having a nominal output of 37 millibars.
- The length of the hose must not exceed 1.5 metres.
- Avoid kinking the hose.
- Replacement regulator and hose assemblies must be as specified by Weber-Stephen Products LLC.

GENESIS Burner Valve Orifice Sizes & Consumption Data

BURNER VALVE ORIFICE SIZES			
Country	Gas Category	335 Models	435 Models
China, Cyprus, Czech Republic, Denmark, Estonia, Finland, Hong Kong, Hungary, Iceland, India, Israel, Japan, Korea, Latvia, Lithuania, Malta, the Netherlands, Norway, Romania, Russia, Singapore, Slovakia, Slovenia, South Africa, Sweden, Turkey	I_{3B/P} (30 mbar or 2.8 kPa)	Main Burners 1.02 mm Sear Burner 1.02 mm Side Burner 1.02 mm	Main Burners 0.98 mm Sear Burner 0.98 mm Side Burner 1.02 mm
Belgium, France, Great Britain, Greece, Ireland, Italy, Luxembourg, Portugal, Spain, Switzerland	I_{3s} (28-30/37 mbar)	Main Burners 0.94 mm Sear Burner 0.94 mm Side Burner 0.96 mm	Main Burners 0.92 mm Sear Burner 0.92 mm Side Burner 0.96 mm
Poland	I_{3B/P} (37 mbar)	Main Burners 0.94 mm Sear Burner 0.94 mm Side Burner 0.96 mm	Main Burners 0.92 mm Sear Burner 0.92 mm Side Burner 0.96 mm
Austria, Germany	I_{3B/P} (50 mbar)	Main Burners 0.86 mm Sear Burner 0.86 mm Side Burner 0.85 mm	Main Burners 0.84 mm Sear Burner 0.84 mm Side Burner 0.85 mm

CONSUMPTION DATA		
Gas Category	335 Models	435 Models
I_{3B/P} (30 mbar or 2.8 kPa)	18.7 kW Propane	21.1 kW Propane
	21.6 kW Butane	24.5 kW Butane
	1336 g/h Propane 1572 g/h Butane	1505 g/h Propane 1784 g/h Butane
I_{3s} (28-30/37 mbar)	18.7 kW Propane	21.1 kW Propane
	18.7 kW Butane	21.1 kW Butane
	1336 g/h Propane 1361 g/h Butane	1505 g/h Propane 1533 g/h Butane
I_{3B/P} (37 mbar)	18.7 kW Propane	21.1 kW Propane
	21.6 kW Butane	24.5 kW Butane
	1336 g/h Propane 1572 g/h Butane	1505 g/h Propane 1784 g/h Butane
I_{3B/P} (50 mbar)	18.7 kW Propane	21.1 kW Propane
	21.6 kW Butane	24.5 kW Butane
	1336 g/h Propane 1572 g/h Butane	1505 g/h Propane 1784 g/h Butane

△ IMPORTANT: We recommend that you replace the gas hose assembly on your gas barbecue every five years. Some countries may have requirements that the gas hose be replaced within less than five years, in which case that country's requirement would take precedence.

For replacement hose, regulator, and valve assemblies, contact the Customer Service Representative in your area using the contact information on our web site.
Log on to weber.com.

Installing the LPG Cylinder

LPG Cylinder Placement

There are two possible locations for installing the LPG cylinder:

- Secured inside the cabinet; or,
- Placed on the ground, outside the cabinet.

Note: For customers in Japan, the LPG cylinder must be placed on the ground, outside the cabinet only.

Cabinet Requirements

For the LPG cylinder to fit inside the grill cabinet, the maximum size requirements for cylinders are:

- Cylinder Capacity:** 13 kg maximum
- Cylinder Height:** 587 mm maximum
- Cylinder Width:** 289 mm maximum (rectangular footprint) or 318 mm maximum (round footprint)

The base of the cylinder must fit within the tank holder and rest flat on the bottom.

Several possible cylinder models approved for installation inside the cabinet are illustrated, with dimensions included.

Placing the LPG Cylinder on the Ground

If the LPG cylinder exceeds the maximum size requirements to fit inside the cabinet, then it must be placed on the ground, outside the cabinet.

Follow the instructions that pertain to the cylinder you are using.

Customers in Japan Must Place the LPG Cylinder on the Ground Only

Regulations in Japan require the LPG cylinder to be placed on the ground, outside of the cabinet only. Follow the instructions for placement of the cylinder on the ground.

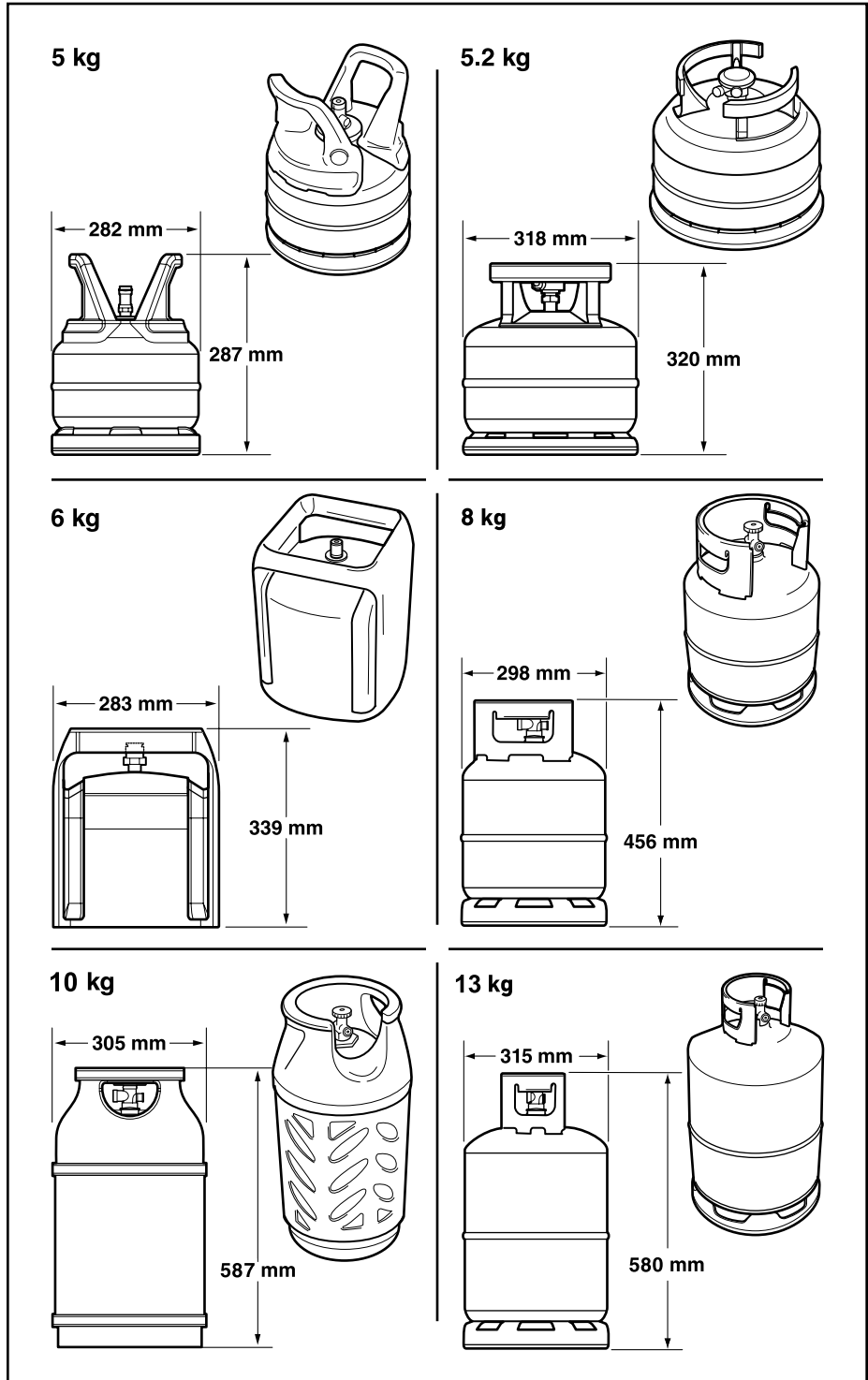
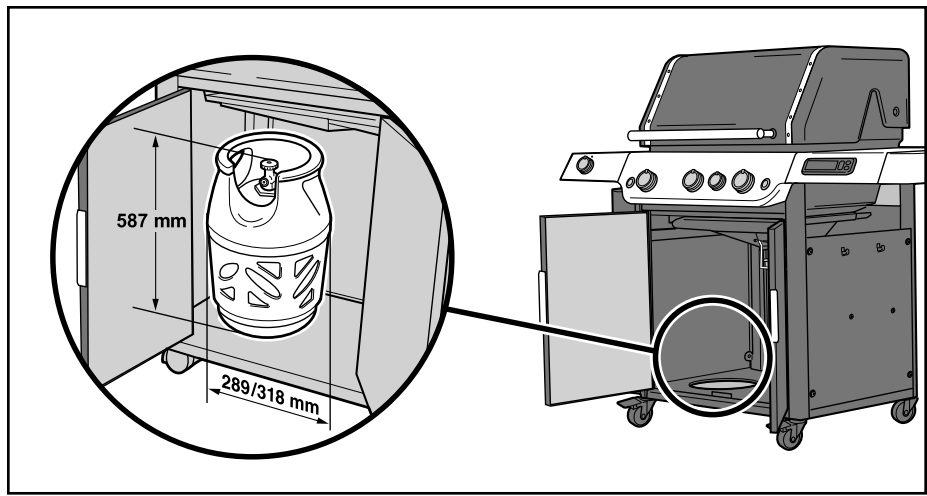

⚠ WARNING: Do not use an LPG cylinder inside the cabinet if it does not meet the cylinder size requirements for placement inside the cabinet.

Installation of the Gas Hose and Regulator

If the gas hose and regulator were not factory installed to the grill, first attach the gas hose to the bulkhead inside the cabinet on the left side panel.

- 1) Open cabinet doors.
- 2) Slide hose retention bracket **(A)** along hose.
Note: The hose retention bracket is only used when the LPG cylinder is installed inside the cabinet.
- 3) Attach the gas hose to the bulkhead **(B)**. Finger tighten the fitting. Then, using a wrench to hold the bulkhead, tighten the fitting a 1/4 turn more with a second wrench.

Leak checks must be performed after connecting the regulator to the LPG Cylinder. Refer to "CONNECTING THE LPG CYLINDER & LEAK CHECKING."

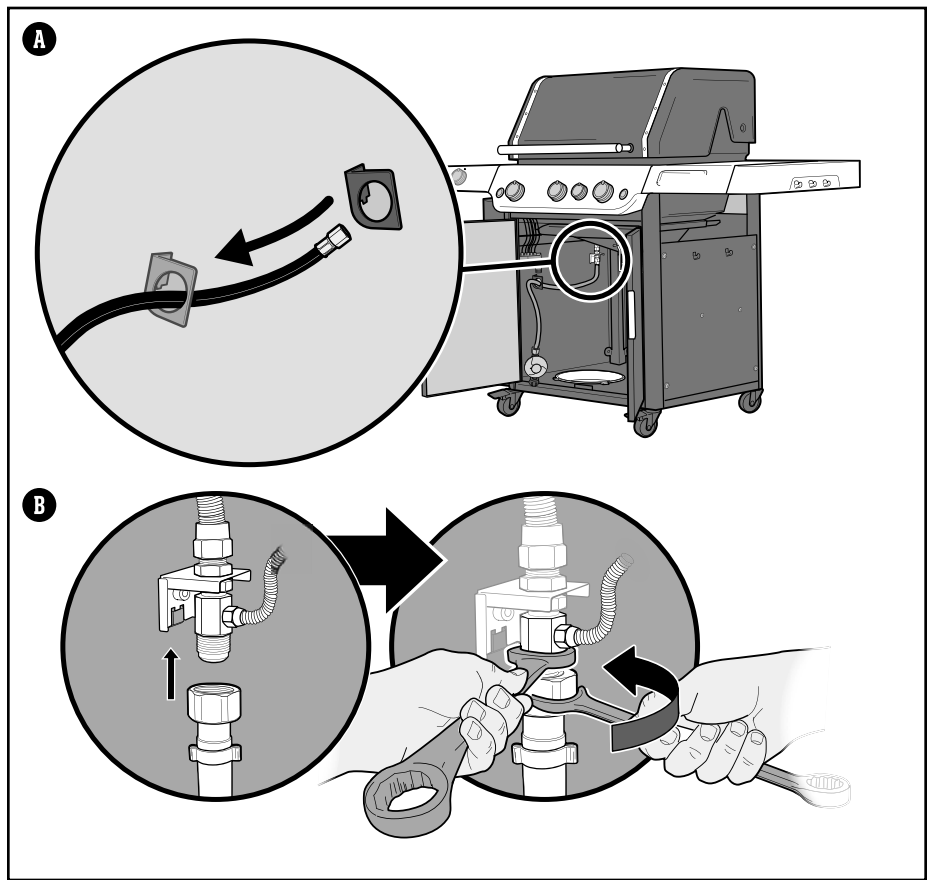

Prepare to Install the LPG Cylinder Inside the Cabinet

For installing the LPG cylinder inside the cabinet, the gas hose must be secured to the side panel with the supplied hose retention bracket.

- 1) Open cabinet doors.
- 2) Slide hose retention bracket (A) along hose to align with mounting tab inside left panel. Secure with one Phillips head screw.

LPG Cylinder Installation

- 1) Lift and place the cylinder into the cylinder holder (B) on the bottom panel. The base of the cylinder must fit within the cylinder holder.
- 2) Turn the cylinder so the valve opening faces the front of the grill.
- 3) Secure the cylinder with the cylinder strap (C).
- 4) Connect the regulator to the LPG cylinder. Refer to "CONNECT THE REGULATOR TO THE CYLINDER."

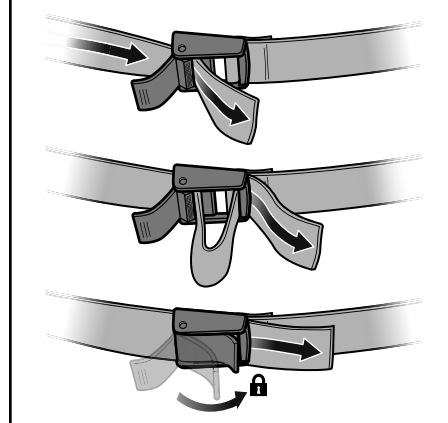
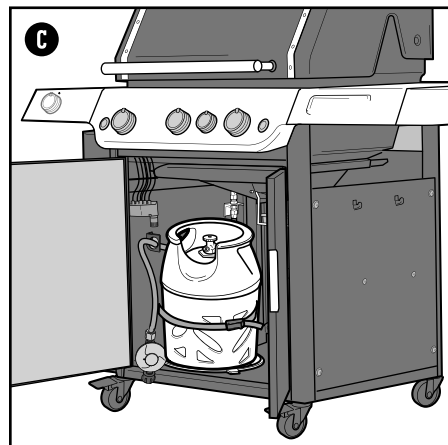
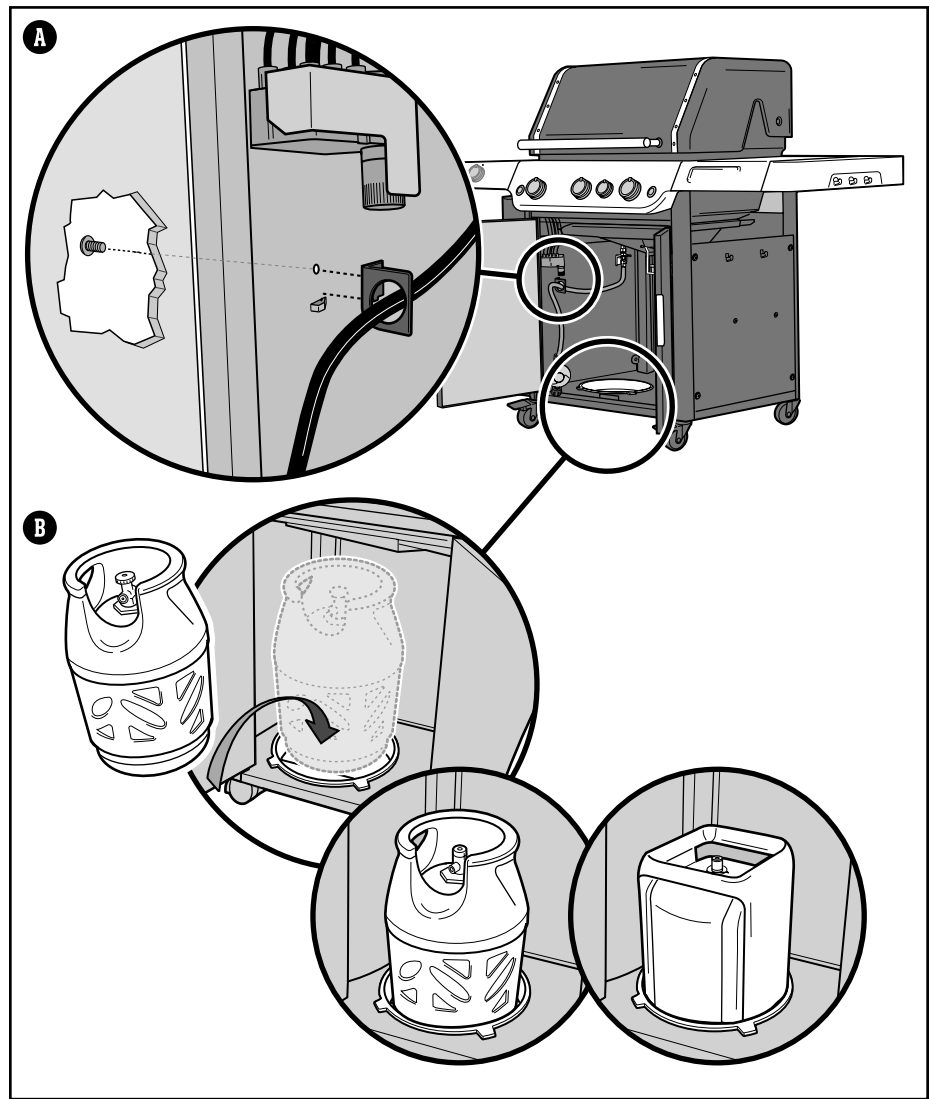

⚠ WARNING: The hose must be secured to the side panel with the hose retention bracket. Failure to do so could cause damage to the hose resulting in a fire or explosion, which can cause serious bodily injury or death, and damage to property.

Maximum LPG cylinder capacity INSIDE cabinet is 13 kg.
The length of hose must not exceed 1.5 metres.

Placement of the LPG Cylinder on Ground

If the LPG cylinder exceeds the maximum size requirements to fit inside the cabinet, then it must be placed on the ground, outside the cabinet.

- 1) Open cabinet door.
- 2) Detach the hose retention bracket from the side panel by loosening the screw **(A)**.
- 3) Pass the hose and regulator out through the back panel opening.
- 4) Place the cylinder on the ground, outside the cabinet, behind the grill **(B)**.
- 5) Turn the LPG cylinder so the opening of the valve is facing away from the grill.
- 6) Connect the regulator to the cylinder. Refer to "CONNECT THE REGULATOR TO THE CYLINDER."

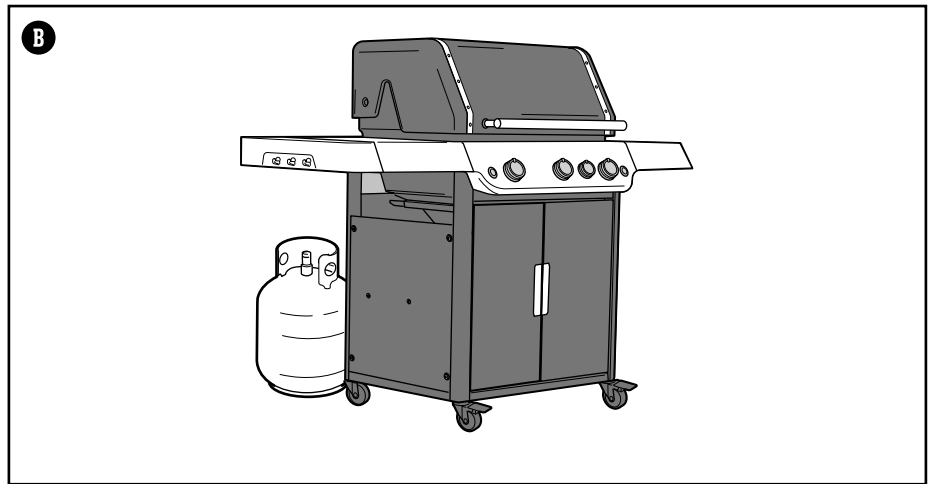
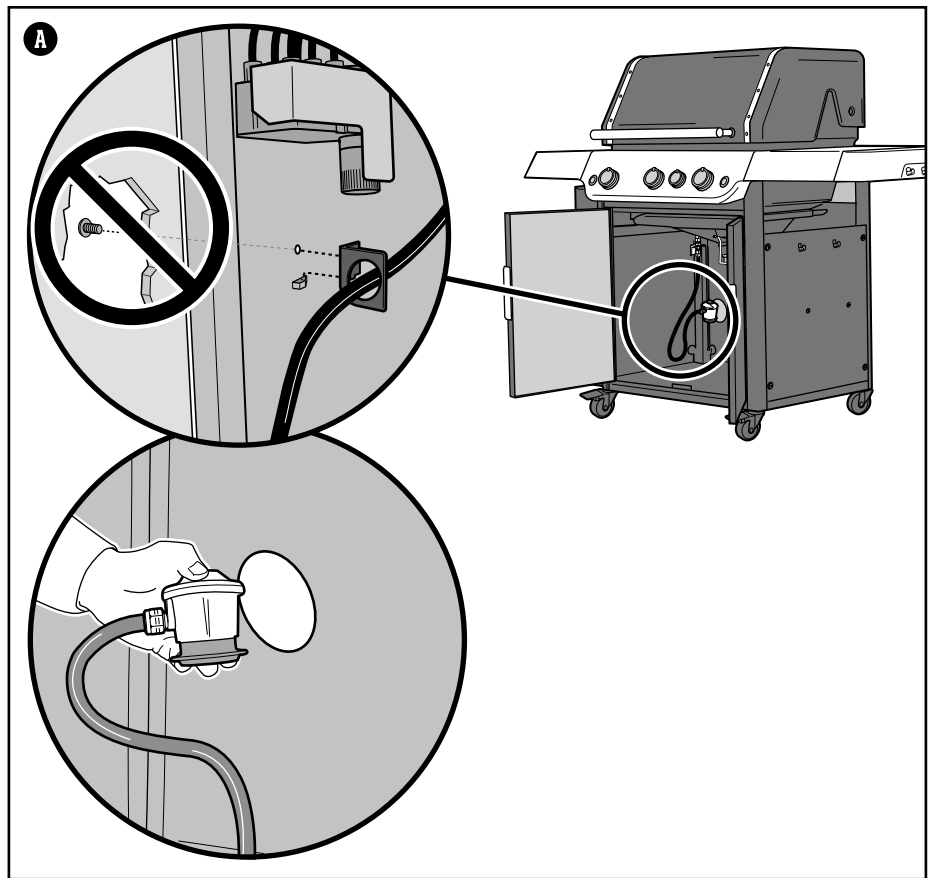

Connecting the LPG Cylinder & Leak Checking

Connect the Regulator to the Cylinder

1) Check that all burner control knobs are in the off O position. Check by pushing in and turning knobs clockwise.

2) Identify your regulator type and connect the regulator to the LPG cylinder by following the appropriate connection instructions.

Note: Confirm that the LPG cylinder valve or regulator lever is closed before connecting.

Connect by Turning Clockwise (A)

Screw regulator onto cylinder by turning fitting clockwise (a). Position the regulator so that the vent hole (b) faces down.

Connect by Turning Anti-Clockwise (B)

Screw regulator onto cylinder by turning fitting anti-clockwise.

Connect by Turning Lever and Snapping into Position (C)

Turn regulator lever (a) clockwise to the off position. Push regulator down on cylinder valve until regulator snaps into position (b).

Connect by Sliding Collar (D)

Make sure regulator lever is in the off position (a). Slide the collar of the regulator up (b). Push the regulator down onto the cylinder valve and maintain pressure. Slide collar down to close (c). If regulator does not lock, repeat procedure.

Note: The regulator illustrations shown in this manual may not be similar to the regulator you are using for your barbecue, due to different country or regional regulations.

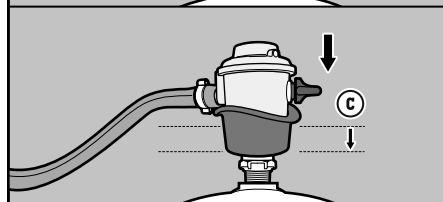
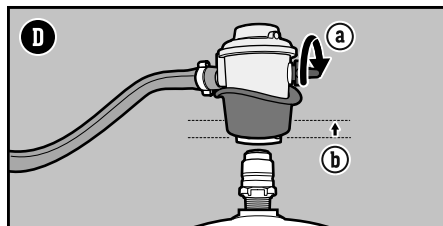
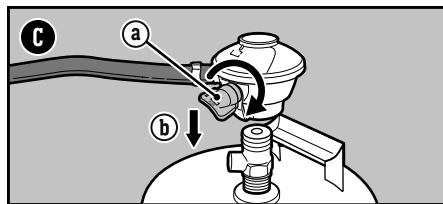
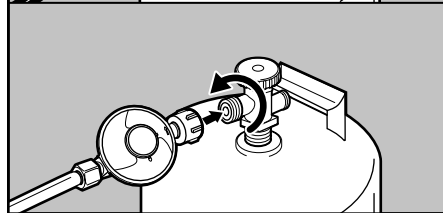
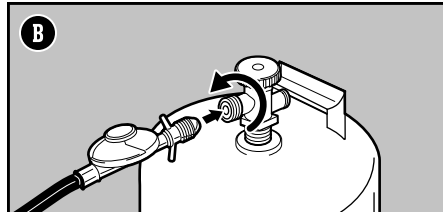
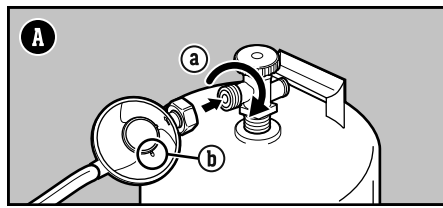

⚠ DANGER: Do not use a flame to check for gas leaks. Be sure there are no sparks or open flames in the area while you check for leaks.

⚠ DANGER: Leaking gas may cause a fire or explosion.

⚠ DANGER: Do not operate the barbecue if there is a gas leak present.

⚠ DANGER If you see, smell, or hear the hiss of gas escaping from the LPG cylinder:

1. Move away from LPG cylinder.
2. Do not attempt to correct the problem yourself.
3. Call the emergency fire services.

⚠ DANGER: Always close the cylinder valve before disconnecting the regulator. Do not attempt to disconnect the gas regulator and hose assembly or any gas fitting while this barbecue is in operation.

⚠ DANGER: Do not store a spare LPG cylinder under or near this barbecue. Never fill the cylinder beyond 80% full. Failure to follow these statements exactly may result in a fire causing death or serious injury.

What is a Leak Check?

Once the LPG cylinder is properly installed, it is necessary to perform a leak check. A leak check is a reliable way to verify that gas is not escaping after you connect the cylinder. The following fittings should be tested each time a cylinder is refilled and reinstalled:

- Where the regulator connects to the cylinder.
- Where the gas hose connects to the bulkhead.
- Where the bulkhead connects to the corrugated gas line.

Checking for Gas Leaks

- 1) Wet fittings with a soap and water solution, using a spray bottle, brush or rag. You can make your own soap and water solution by mixing 20% liquid soap with 80% water; or, you can purchase leak check solution in the plumbing section of any hardware store.
- 2) Identify your regulator type. Turn gas supply on by turning cylinder valve anti-clockwise **(G)** or by moving regulator lever to the on position **(H)**.

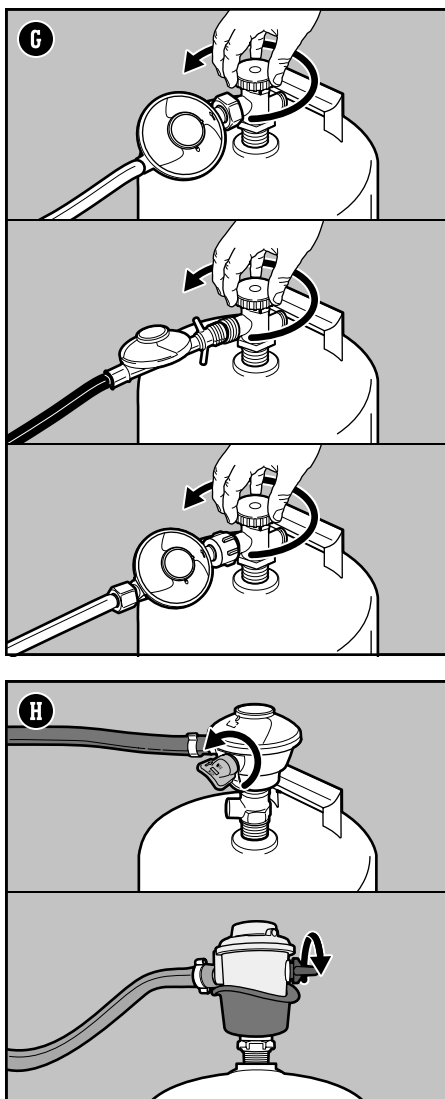

⚠ **DANGER:** Do not use a flame to check for gas leaks. Be sure there are no sparks or open flames in the area while you check for leaks.

⚠ **DANGER:** Leaking gas may cause a fire or explosion.

⚠ **DANGER:** Do not operate the barbecue if there is a gas leak present.

⚠ **DANGER:** If you see, smell, or hear the hiss of gas escaping from the LPG cylinder:

1. Move away from LPG cylinder.
2. Do not attempt to correct the problem yourself.
3. Call the emergency fire services.

⚠ **DANGER:** Always close the cylinder valve before disconnecting the regulator. Do not attempt to disconnect the gas regulator and hose assembly or any gas fitting while this barbecue is in operation.

⚠ **DANGER:** Do not store a spare LPG cylinder under or near this barbecue. Never fill the cylinder beyond 80% full. Failure to follow these statements exactly may result in a fire causing death or serious injury.

3) If bubbles appear there is a leak:

- a) If the leak is at the regulator-to-cylinder connection or the regulator hose-to-regulator connection (I), turn gas supply off. DO NOT OPERATE THE BARBECUE.
- b) If the leak is at any fittings indicated in illustration (J), re-tighten fitting with a wrench and recheck for leaks with soap and water solution. If leak persists, turn off the gas. DO NOT OPERATE THE BARBECUE.
- c) If the leak is at any fittings indicated in illustration (K), turn off the gas. DO NOT OPERATE THE BARBECUE.

If a leak is present, contact the Customer Service Representative in your area using the contact information on our website.

4) If bubbles do not appear, leak checking is complete:

- a) Turn gas supply off and rinse connections with water.

NOTE: Since some leak test solutions, including soap and water, may be slightly corrosive, all connections should be rinsed with water after checking for leaks.

Additional Leak Check Precautions

The following fittings should be tested for gas leaks each time a tank is refilled and reinstalled:

- At the regulator and where the regulator connects to the cylinder (I).

Follow the instructions for "Checking for Gas Leaks".

Disconnect the Regulator from the Cylinder

To remove a cylinder:

- 1) Confirm that the LPG cylinder valve or regulator lever are fully closed.
- 2) From inside cabinet release the clasp on the cylinder retention strap.
- 3) Disconnect the regulator.
- 4) Remove the cylinder.

Use caution if replacing an LP cylinder (tank) during a cook. The entire cookbox and grease management system gets hot when in use. Always wear heat resistant gloves or Mitts when handling the LP Cylinder (tank). Fasten cylinder strap after connecting new cylinder.

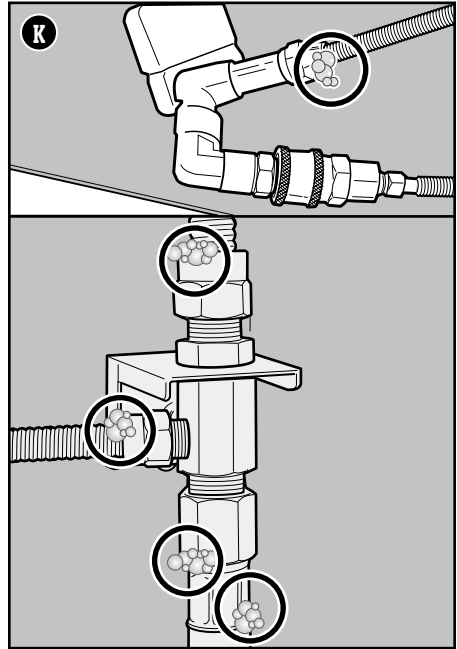
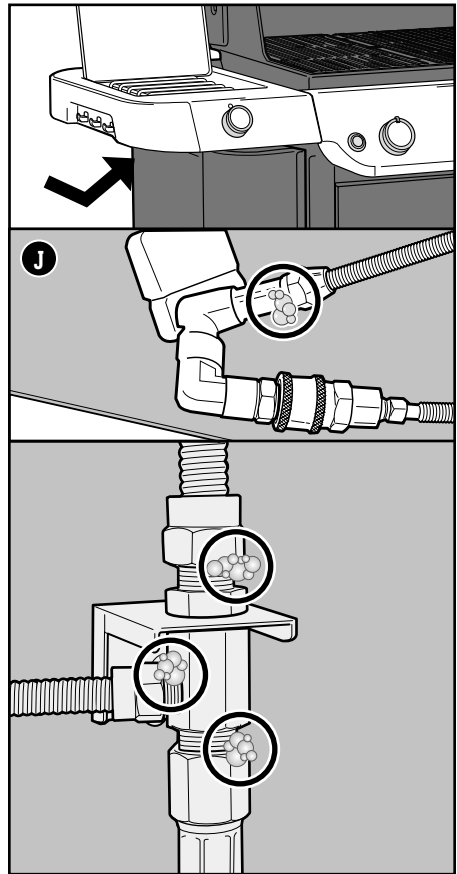
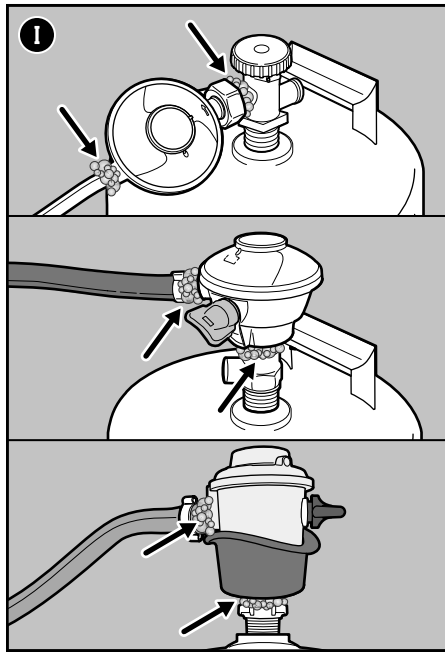

The Very First Time You Grill

Perform an Initial Burn-Off

Heat the grill on the highest setting, with the lid closed, for at least 20 minutes prior to grilling for the first time.

Every Time You Grill

Meal-to-Meal Maintenance

The Meal-To-Meal Maintenance plan includes the following simple, yet important, steps that should always be performed prior to grilling.

Check for Grease

Your grill was built with a grease management system that funnels grease away from food and into a disposable container. As you cook, grease is channeled down the slide-out grease tray and into a disposable drip tray that lines the catch pan. This system should be cleaned each and every time you grill to prevent fires.

1. Confirm that the grill is off and cool.
2. Open the doors.
3. Access the slide-out grease tray by pulling the tray towards you until it stops (A). Remove excess grease with a plastic scraper. Scrape the grease down through the opening in the grease tray, into the catch pan below.
4. Remove the catch pan (B). Check for excessive amounts of grease in the disposable drip pan that lines the catch pan. Discard disposable drip pan when necessary and replace with a new one.
5. Reinstall all components.

Inspect the Hose

Routine inspection of the hose is necessary.

1. Confirm that the grill is off and cool.
2. Check hose for any signs of cracking, abrasions, or cuts (C). If the hose is found to be damaged in any way, do not use the grill.

Check the Power Cord

Routine inspection of the power cord is necessary.

1. Confirm that the grill is off and cool.
2. Check the power cord for any signs of cuts or damage. If the power cord is found to be damaged in any way, do not use the grill.
3. Plug the power cord into the port beneath the side table (D) before plugging it into a grounded electrical outlet.
4. Turn on the main power switch (E).

Preheat the Grill

Preheating the grill is critical to successful grilling. Preheating helps to prevent food from sticking to the grate and gets the grate hot enough to sear properly. It also burns off residue of a previously cooked meal.

1. Open the grill lid.
2. Ignite your grill according to the ignition instructions in this Owner's Manual.
3. Close lid.
4. Preheat the grill with all burners on the start/high position for 15 minutes (F).

Clean the Cooking Grate

After preheating, any bits of food or debris left over from previous use will be easier to remove. Cleaned grates will also prevent your next meal from sticking.

1. Brush the grates with a stainless steel bristle grill brush immediately after preheating (G).

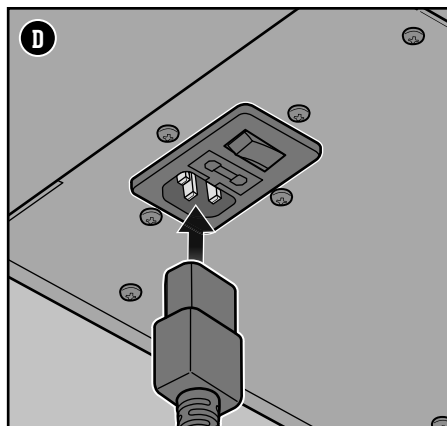
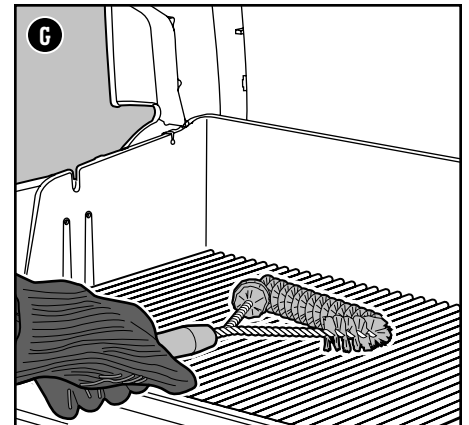
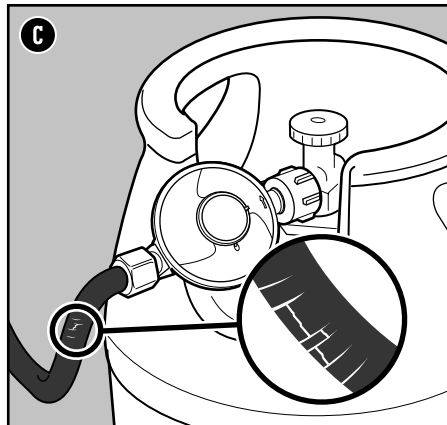
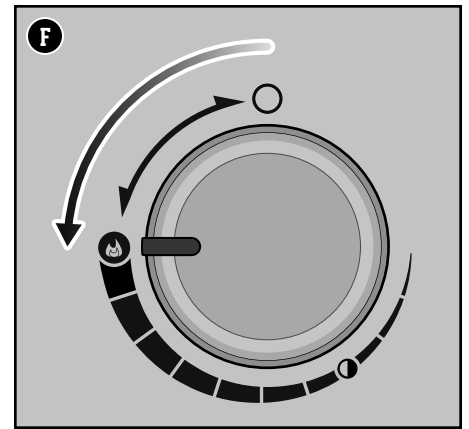
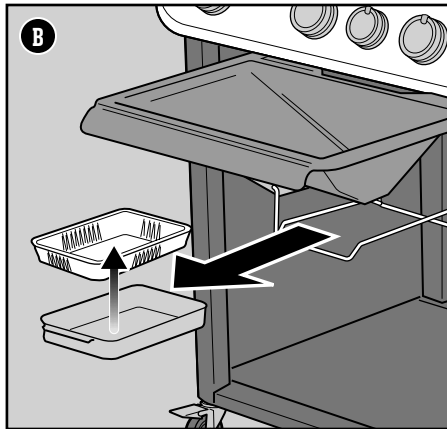
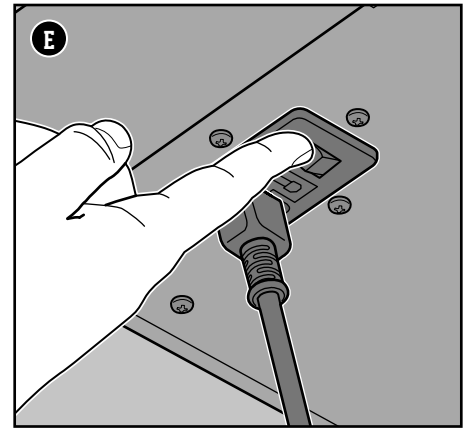
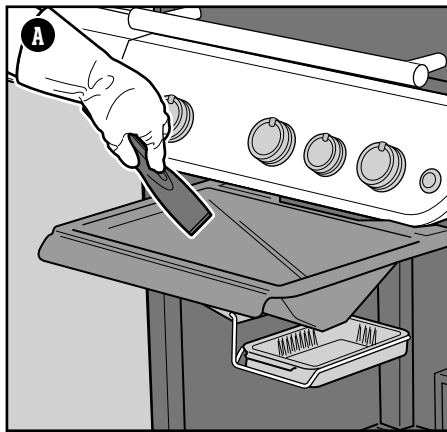

⚠ **DANGER:** Do not line the slide-out grease tray or cookbox with aluminum foil.

⚠ **DANGER:** Check the slide-out grease tray and catch pan for grease build-up before each use. Remove excess grease to avoid a grease fire.

⚠ **WARNING:** Use caution when removing catch pan and disposing of hot grease.

⚠ **WARNING:** Use heat-resistant barbecue mitts or gloves when operating grill.

⚠ **WARNING:** Grill brushes should be checked for loose bristles and excessive wear on a regular basis. Replace brush if any loose bristles are found on cooking grates or brush. WEBER recommends purchasing a new stainless steel bristle grill brush at the beginning of every spring.

⚠ **WARNING:** If the hose is found to be damaged in any way, do not use the grill. Replace using only WEBER authorized replacement hose.





⚠ **WARNING:** Keep ventilation openings around tank clear and free of debris.

⚠ **WARNING:** Keep any electrical supply cord and the fuel supply cord away from heated surfaces.

Igniting the Grill

Using the Electronic Ignition System to Ignite the Grill

Each control knob operates an individual burner, and each burner ignites independently. Ignite the burners starting from left to right. All burners should be lit for preheating, however, all burners do not have to be lit while grilling.

- 1) Open the grill lid (A).
- 2) Check that all burner control knobs are in the off  position. Check by pushing in and turning knobs clockwise (B).
Note: It is important that all burner control knobs are in the off  position before turning on the LPG cylinder.
- 3) Turn gas supply on by turning cylinder valve anti-clockwise or by moving regulator lever to the on position depending on your regulator/cylinder connection.
- 4) Begin with the burner furthest to the left. Push the burner control knob in and turn it anti-clockwise to the start/high  position (C).
- 5) Push and hold the electronic ignition button (D). You will hear it ticking.
- 6) Check that the burner is lit by looking through the cooking grates and through the half-circle cutout in the FLAVORIZER BARS.
- 7) If the burner does not ignite, turn burner control knob to the off  position and wait five minutes to allow the gas to clear before attempting to light the burner again.
- 8) If the burner ignites, repeat steps 4 through 6 to light the remaining burners.

Should the burners fail to ignite using the electronic ignition, refer to the TROUBLESHOOTING section. There you will find instructions on igniting the grill with a match to help determine the exact problem.

To Extinguish Burners

- 1) Push each burner control knob in and then turn clockwise all the way to the off  position.
- 2) Turn gas supply off at the LPG cylinder.

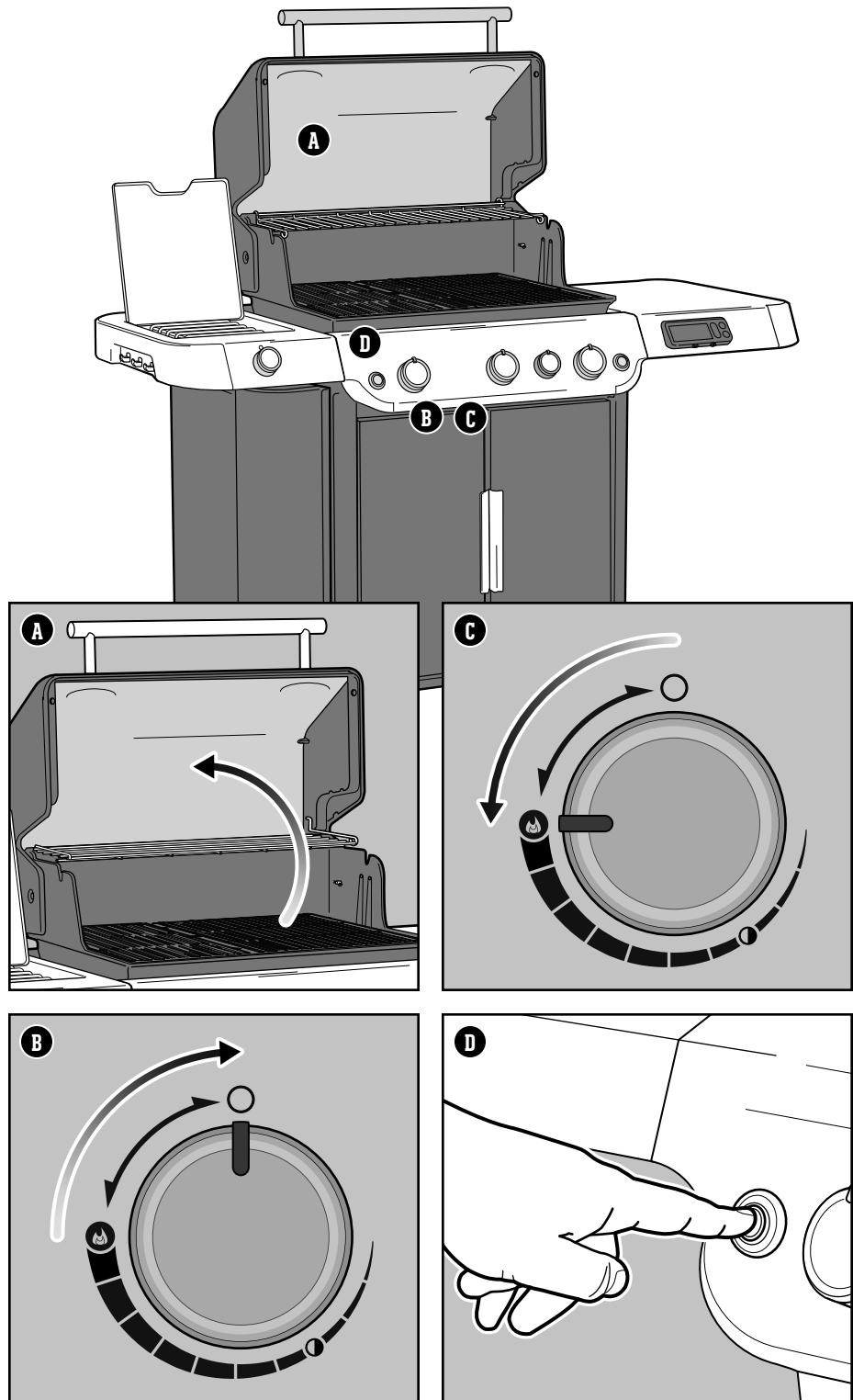



- ⚠ WARNING: Open lid during ignition.
- ⚠ WARNING: Do not lean over open grill while igniting or cooking.
- ⚠ WARNING: Each burner must be ignited individually by pushing the electronic ignition button.
- ⚠ WARNING: If ignition does not occur within four seconds of attempting to light the first burner, turn the burner control knob to the off position. Wait five minutes to allow accumulated gas to dissipate, and then repeat the lighting procedure.

Using the sear zone

Searing is a direct grilling technique used on meats, such as steak, poultry parts, fish and chops. Searing browns the surface of the food at a high temperature. By searing both sides of the meat, you caramelize the food surface, creating a more desirable flavor.

Ignition of the sear burner is the same as ignition of a main burner, each burner ignites independently.

- 1) Open the lid and ignite all of the burners, including the sear burner. Refer to USING THE ELECTRONIC IGNITION SYSTEM TO IGNITE THE GRILL.
- 2) Preheat the grill with the lid closed and with all burners on the start/high  position for 15 minutes.
- 3) After preheating, leave the sear burner control knob and the adjacent burner control knobs in the start/high  position (A). The sear burner works in tandem with adjacent burners (B). The remaining burner(s) can be turned to off or low.
- 4) Place meat directly over the sear zone and close lid. Sear each side anywhere from one to four minutes (C), depending on the type and thickness of meat. Once searing is complete, the meat can be moved to moderate heat over and cooked to your desired doneness.

Note: Always cook with the lid closed to achieve maximum heat and to avoid flare-ups.

As you gain experience using the sear zone we encourage you to experiment with different searing times to find the results that work best for your taste.

To Extinguish Burners



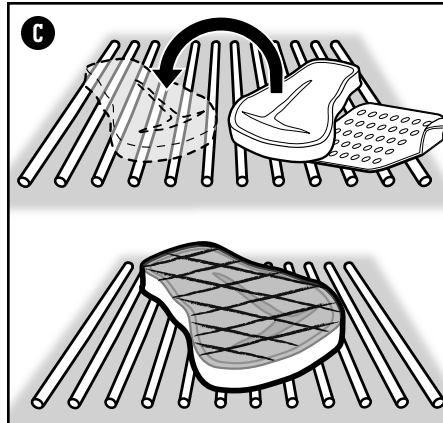
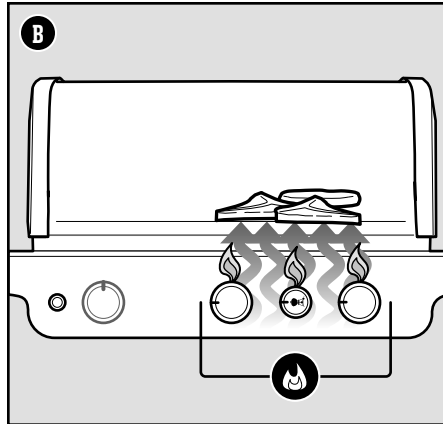
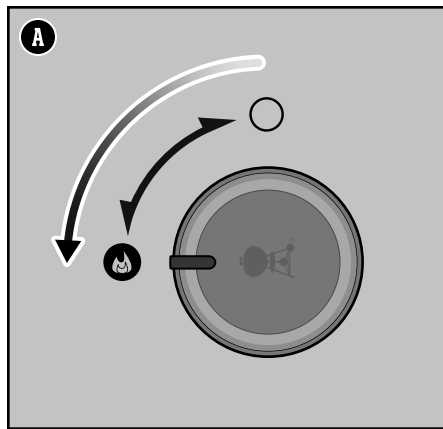

- 1) Push each burner control knob in and then turn clockwise all the way to the off  position.
- 2) Turn gas supply off.



Igniting the Side Burner

Using the Electronic Ignition to Ignite the Side Burner

If one or more of the main burners on your grill are already lit and you would like to ignite the side burner, skip to step 3. If none of the main burners are lit and you are only using the side burner, start with step 1.

- 1) Check that the side burner control knob is in the off  position. Check by pushing in and turning knob clockwise (A). Also check that all main burner control knobs are in the off  position.
Note: It is important that all burner control knobs are in the off  position before turning on the LPG cylinder.
- 2) Turn gas supply on by turning cylinder valve anti-clockwise or by moving regulator lever to the on position depending on your regulator/cylinder connection.
- 3) Open the side burner lid (B).
- 4) Push in and turn side burner control knob anti-clockwise to start/high  position (C).
- 5) Push and hold in the electronic ignition button (D). You will hear the igniter clicking. Check that the side burner is lit. The side burner flame may be difficult to see on a bright sunny day.
- 6) Once side burner is ignited, continue turning the knob anti-clockwise until you reach the desired position.
- 7) If the side burner does not ignite within 4 seconds, turn side burner control knob to the off  position and wait five minutes to allow the gas to clear before attempting to light the burner again.

Should the side burner fail to ignite using the electronic ignition, refer to the TROUBLESHOOTING section. There you will find instructions on igniting the side burner with a match to help determine the exact problem.

To Extinguish Side Burner

- 1) Push side burner control knob in and then turn clockwise all the way to the off  position.
- 2) Turn gas supply off at the LPG cylinder.

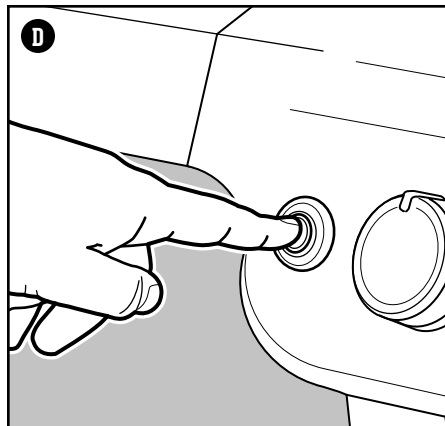
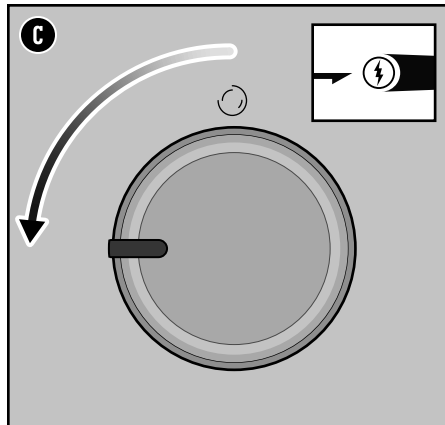
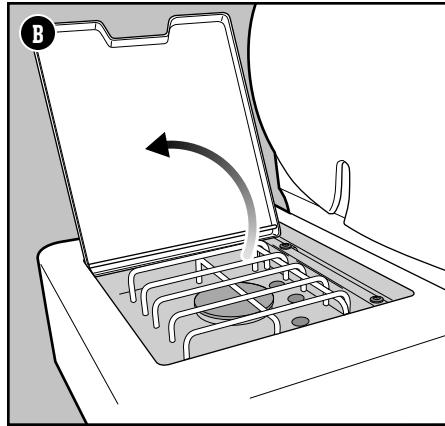
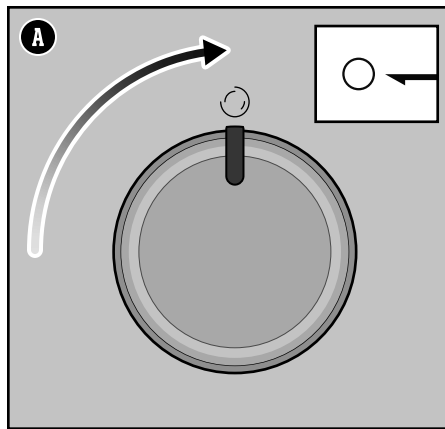

⚠ WARNING: Open side burner lid during ignition.

⚠ WARNING: Do not lean over side burner while igniting or cooking.

⚠ WARNING: If ignition does not occur within four seconds of attempting to light the side burner, turn the burner control knob to the off position. Wait five minutes to allow accumulated gas to dissipate, and then repeat the lighting procedure.

Integrated WEBER CONNECT Technology



Weber Connect App

First things first.

Download the WEBER CONNECT app.

Open the app to receive:

- Flip and serve notifications
- Food Readiness Countdowns
- Custom Food Doneness Alerts
- Step-by-step Grilling Assistance

Connecting Your Grill To Bluetooth® or Wi-Fi Network

To connect your WEBER grill via Bluetooth® or your local Wi-Fi network, follow these steps:

NOTE: WEBER recommends that your smart device be running the latest version of its operating system before attempting to connect your grill to Bluetooth® or your Wi-Fi network.

- 1) Push any button located on the temperature controller to turn ON the WEBER CONNECT module.
- 2) Verify that your smart device is connected to Bluetooth® or your local Wi-Fi network.
- 3) From your smart device, download the new WEBER CONNECT app from the App Store on Apple devices, or the Play Store on Android devices.
- 4) Open the WEBER CONNECT app and follow the in-app instructions for connecting to your WEBER grill.

NOTE: In order to successfully connect your smart device to your grill via a local Wi-Fi network, first make sure your grill is paired via Bluetooth® and that your grill is within range of your Wi-Fi router. If your attempts to connect have been unsuccessful, try moving the grill within range of the Wi-Fi router or adding a signal extender for a stronger signal.

Using the WEBER CONNECT Module

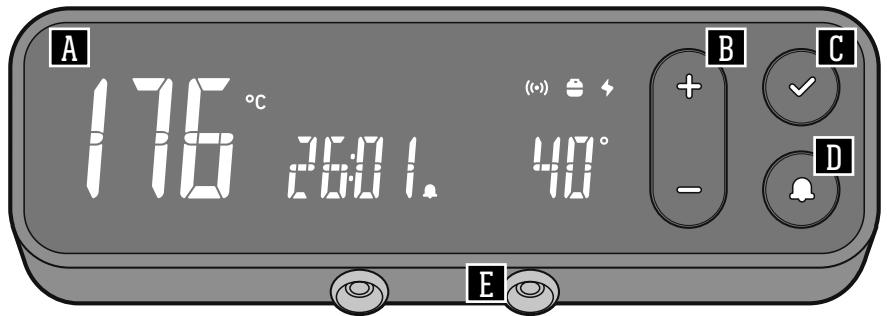



Model: WC2 CONTROLLER

A Dashboard

The LED display dashboard on your module is where you can visually check temperatures, receive notifications, view connectivity status, and check the status of your cook.





B

Push the  or  buttons to increase or decrease target temperatures. Push the  button to confirm your selection.

C Confirm Selection / Turn Display Off

After selecting a target temperature, push the  button confirm the selection. Hold the same button for three seconds to turn off the display.



D Target Temperature Alert

Push the  button to set an alert for the grill and/or meat probe temperatures. Push the  or  buttons to increase or decrease the desired target temperature. Push the  button to confirm the target temperature alert. To clear alert, select desired input and press/hold the  button until dash marks appear.

E Food Temperature Probes

Your new WEBER CONNECT module can handle up to two separate food temperature probes (one probe included) to gain superior control of your grill for perfect results every time.

NOTE: Download the WEBER CONNECT app to get the latest grill software and features.

Notifications	
	Power Indication
	A green wireless symbol is shown on the WEBER CONNECT module display when connected to the WEBER CONNECT app via your local Wi-fi network. A blue wireless symbol is shown on the WEBER CONNECT module display when connected to the WEBER CONNECT app via Bluetooth®.
	A bell alert icon will display when a target temperature is set.

Setting a Grill Temperature Notification

Please follow these steps for setting a notification to alert you when your grill has reached a target internal temperature:

- 1) Push any button located on the temperature controller to turn ON the WEBER CONNECT module.
- 2) Push the BELL button to activate grill temperature notification.
- 3) While the display is blinking, push the + or - buttons to set the target grill temperature. Push the CHECKMARK button to confirm your selection.
- 4) Repeat steps 2 and 3 to update or set a new target temperature.
- 5) Once the grill reaches the target temperature, the BELL button will blink, the controller will ding, and if using the WEBER CONNECT app, you will receive a push notification on your smart device.
- 6) All of these WEBER CONNECT module functions can also be set wirelessly via Wi-fi or Bluetooth® from the WEBER CONNECT app on your smart device.

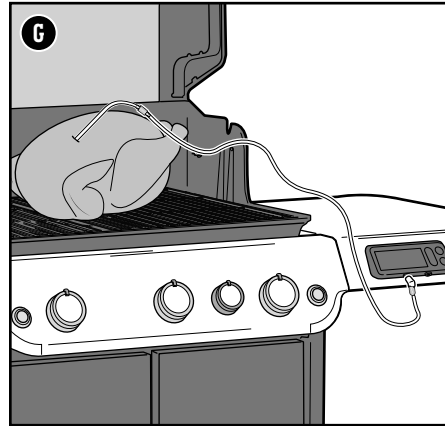
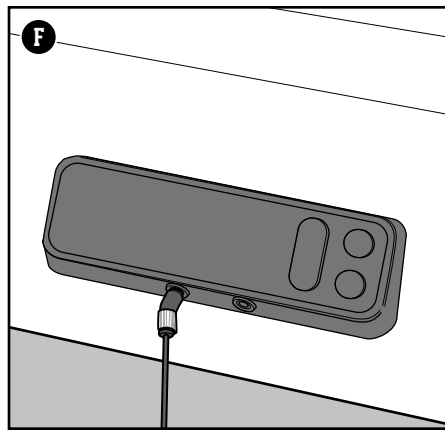

Grilling with Food Temperature Probes

Use the included food temperature probe to monitor your WEBER grill for the perfect food, every time.

Please follow these steps for using food temperature probes:

- 1) Once the grill has been preheated, open the grill lid and clean the cooking grates using a grill brush or scraper, then set the control knobs to the desired grill temperature.
- 2) Place your food on the grates.
- 3) Plug the food temperature probe(s) into the ports of the WEBER CONNECT module (F) and, using heat resistant grill mitts or gloves, route food temperature probe cables through the side channel on the grill (G).
- 4) Insert food probe(s) into the center of the thickest part of your food.
- 5) Close the grill lid.
- 6) Push any button located on the temperature controller to turn ON the WEBER CONNECT module.
- 7) Push the BELL button to navigate between grill temperature and food temperature probes 1 and 2.
- 8) Once you select which probe you are using, push the + or - buttons to set the target food temperature. Push the CHECKMARK button to confirm your selection.
- 9) Repeat steps 7 and 8 to update or set a new target temperature.
- 10) Once the probe reaches the target temperature, the BELL button will blink, the controller will ding, and if using the WEBER CONNECT app, you will receive a push notification on your smart device.
- 11) All of these WEBER CONNECT module functions can also be set wirelessly via Wi-fi or Bluetooth® from the WEBER CONNECT app on your smart device.

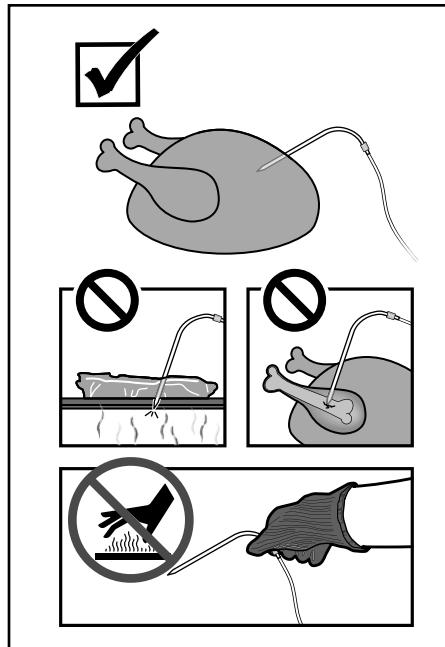

Food Temperature Probe Care

Cleaning the Food Temperature Probe

Clean probe before first use. The probe should be cleaned by wiping with water and a damp cloth.

The food temperature probes are not dishwasher safe or waterproof and damage may result from excessive water exposure. Never submerge the probes directly in water or other liquids.

Storing Food Temperature Probe

Once cleaned, neatly wrap the probe when not in use and store indoors.

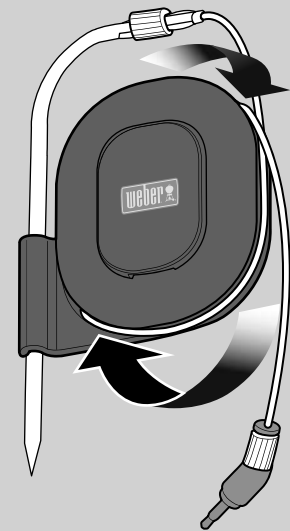
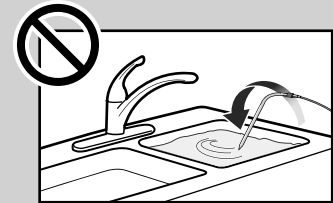

⚠ WARNING:

⚠ Risk of injury! The food temperature probes are very sharp. Please be careful when handling probes.

⚠ Risk of burns! Handling the food temperature probes without hand protection will result in severe burns. The colored probe indicators are not intended to be touched with bare hands while using the grill as they are not heat-insulated. Please wear heat-resistant gloves at all times while using this product in order to avoid being burned.

The Flame - Direct or Indirect

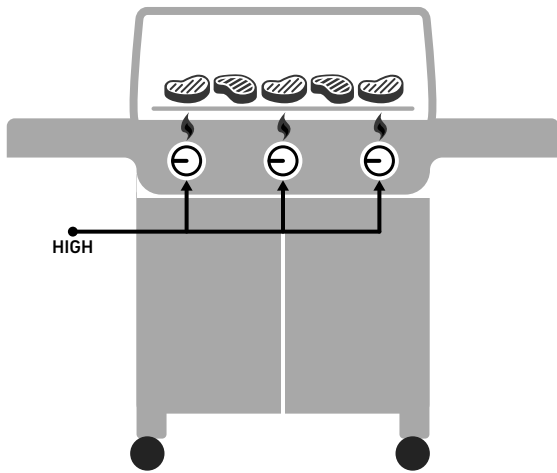

DIRECT HEAT SETUP

Use the direct method for small, tender pieces of food that take less than 20 minutes to cook, such as: hamburgers, steaks, chops, kabobs, boneless chicken pieces, fish fillets, shellfish, and sliced vegetables.

With direct heat, the fire is right below the food. It sears the surfaces of the food, developing flavors, texture, and delicious caramelization while cooking the food all the way to the center.

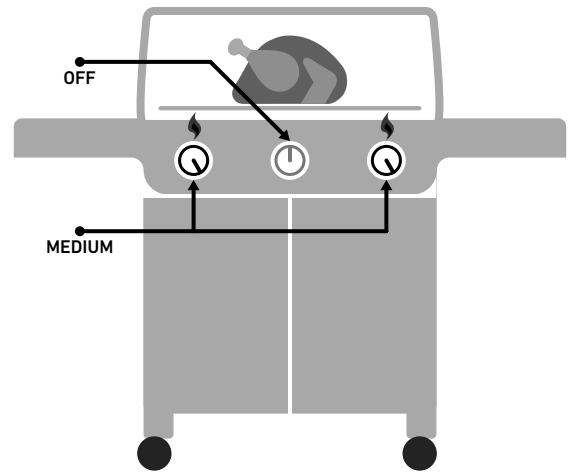

INDIRECT HEAT SETUP

Use the indirect method for larger cuts of meat that require 20 minutes or more of grilling time, or for foods so delicate that direct exposure to the heat would dry them out or scorch them, such as: roasts, bone-in poultry pieces, whole fish, delicate fish fillets, whole chickens, turkeys, and ribs. Indirect heat can also be used for finishing thicker foods or bone-in cuts that have been seared or browned first over direct heat.

With indirect heat, the heat is on both sides of the grill, or off to one side of the grill. The food sits over the unlit part on the cooking grate.

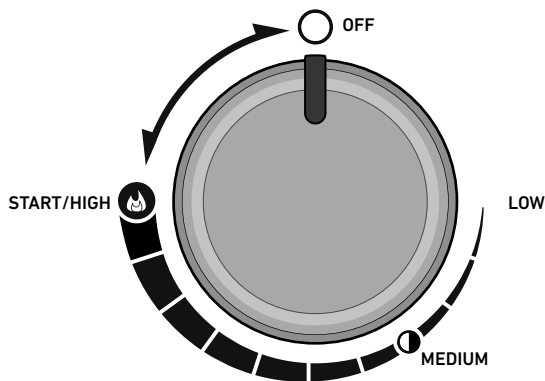

BARBECUE MITTS

When in doubt, wear them. The good ones are insulated and protect both hand and forearm.

MUST-HAVE GRILLING TOOLS • MUST-HAVE GRILLING TOOLS • MUST-HAVE GRILLING TOOLS • MUST-HAVE GRILLING TOOLS • MUST-HAVE GRILLING TOOLS

Discover What's Possible

WEBER CRAFTED Outdoor Kitchen Collection Ready

This feature is only available on select models.

Some models are Outdoor Kitchen Collection Ready with the included Grates and Frame. Remove the right-hand cooking grate. Place the Frame on the right-hand side of the cookbox for the widest range of heat control **(A)**.

The Spacer included with your grill is used only when cooking with the WEBER CRAFTED Outdoor Kitchen Collection **(B)**.

Look for these and other accessories on weber.com.

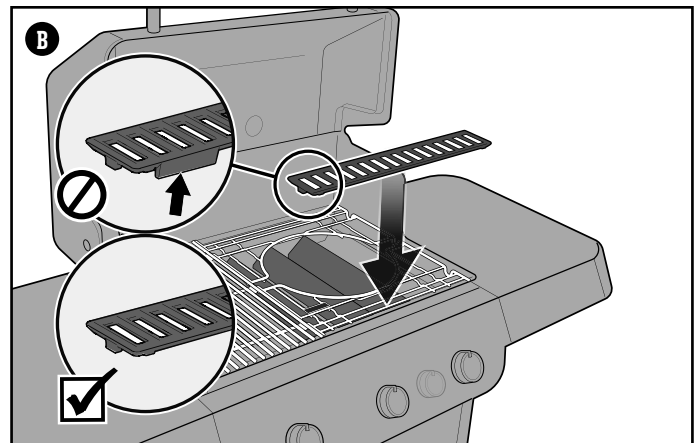
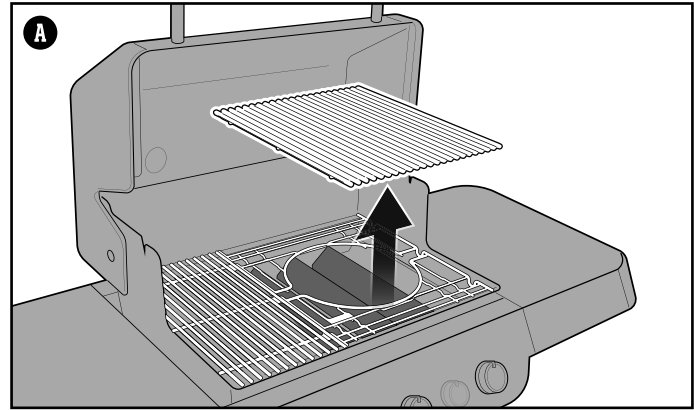

Grilling Do's and Don'ts

Preheat each and every time.

If the cooking grates aren't hot enough, food will stick, and you will likely never have a chance of searing properly or developing those handsome grill marks. Even if a recipe calls for medium or low heat, always preheat the grill on the highest setting first. Open the lid, turn up the heat, close the lid, and then let the cooking grate heat up for 15 minutes on high.

Don't grill on dirty grates.

Tossing food onto the cooking grates before they have been cleaned is never a good idea. Leftover "stuff" on the grates acts like glue, binding it to the grates and your new food. To avoid tasting last night's dinner on today's lunch, make sure you are grilling on a clean cooking grate. Once the grates are preheated, use a stainless steel bristle grill brush to make a clean, smooth surface.

Be present in the process.

Before firing up your grill, make sure that everything you need is within arm's reach. Don't forget your essential grilling tools, already oiled and seasoned food, glazes or sauces, and clean cooking platters for cooked food. Having to run back to your kitchen not only means missing out on the fun, but could also result in burning your food. French chefs call this "mise en place" (meaning, "put in place"). We call it "being present".

Create a little elbow room.

Packing too much food onto the cooking grates restricts your flexibility. Leave at least one-quarter of the cooking grates clear with plenty of space between each food item in order to get your tongs in there and easily move the food around. Sometimes grilling involves split-second decisions and the ability to jockey food from one area to another. So give yourself enough room to operate.

Try not to peek.

The lid on your grill is for more than just keeping the rain out. Most importantly, it's for preventing too much air from getting in and too much heat and smoke from getting out. When the lid is closed, the cooking grates are hotter, the grilling times are faster, the smoky tastes are stronger, and the flare-ups are fewer. So put a lid on it!

Only flip once.

What's better than a juicy steak with a deep sear and plenty of beautifully caramelized bits? The key to accomplishing these results is to keep your food in place. Sometimes we have the tendency to flip our food before it reaches the desirable level of color and flavor. In nearly all cases, you should turn food just once. If fiddling with it more than that, you are probably also opening the lid too much, which causes its own set of problems. So step back and trust the grill.

Know when to tame the flame.

When grilling, sometimes the most important thing to know is when to stop. The most reliable way to test doneness of your food is to invest in an instant-read thermometer. This slim little gem will help you pinpoint that critical moment when your food is at its best.

Don't be afraid to experiment.

Back in the 1950s, grilling meant one thing: meat (and only meat) charred over open flames. The modern day backyard chef doesn't need a kitchen in order to prepare a full course meal. Use your grill to make char-grilled appetizers, sides, and even desserts. Register your grill to receive special content that will inspire you along the way. We'd love to join you on your grilling adventures.

Real Smoke Flavor

Using the Smoker Box

This feature is only available on select models.

Use dry wood chips in the smoker box as they ignite quickly and create smoke faster. For longer cooking foods such as roasts, chicken, and turkeys, etc., fill the entire length of the smoker box with wood chips. The wood chips will ignite on the end of the smoker box which is positioned over the burner and slowly continue to burn inside the smoker box to provide smoke throughout the cook. As you gain experience in using your smoker, we encourage you to experiment with different combinations of wood chips to find the smoke flavor that best suits your taste.

Option 1: Setting up for Indirect Cooking

- 1) Open the grill lid.
- 2) Check that all burner control knobs are in the off position and the grill is cool. Check by pushing in and turning knobs clockwise.
- 3) Remove the cooking grates to expose the FLAVORIZER BARS (A).
- 4) Open the lid of the smoker box.
- 5) Fill the smoker box with wood chips from end to end (B). Close the smoker box lid.
- 6) With the grill off, position the smoker box over the two right-hand side FLAVORIZER BARS, near the front of the grill, making sure only the narrow end with the WEBER logo will be directly over a lit burner (C). This is the end where the wood chips ignite first. The main body of the smoker box aligns on a FLAVORIZER BAR without a lit burner beneath it.
- 7) Add water to the water pan of the smoker box (D) for more flavorful smoke during the cook.
- 8) Reinstall the cooking grates over the smoker box (E).
- 9) Ignite the grill and preheat for 10 minutes with only the main burners on high. Refer to "Igniting the Grill". After preheating, turn off center burner and reduce outer burners to low (F).

Smoke will start in approximately 10 minutes and last as long as 90 minutes. Do not attempt to move hot components to refill the smoker with wood chips. Keep the lid of the grill closed while cooking.

Option 2: Setting up for Direct Cooking

The smoker box is positioned where the Weber logo is over the center burner during grilling, with main burners set on low (G).

NOTES

For best smoking results, burners in use should be on low. Do not place the main body of the smoker box directly over a burner. This could ignite all of the wood chips at once resulting in reduced smoking times.

Always grill with the lid closed to allow the smoke to fully penetrate the food.

When you're finished smoking, turn burners off and close the grill lid until the wood chips have extinguished.

Remove smoker box from the grill if not in use.

Cleaning the Smoker Box

Before each use, empty the smoker of ash to allow proper air flow.

Note: Smoking will leave a "smoke" residue on the surface of the smoker. This residue cannot be removed and will not affect the function of the smoker. To a lesser degree, a "smoke" residue will accumulate on the inside of your gas grill. This residue need not be removed and will not adversely affect the function of your gas grill.

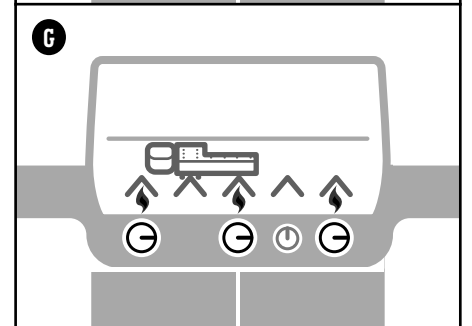
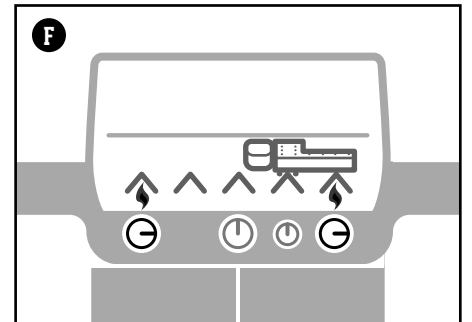
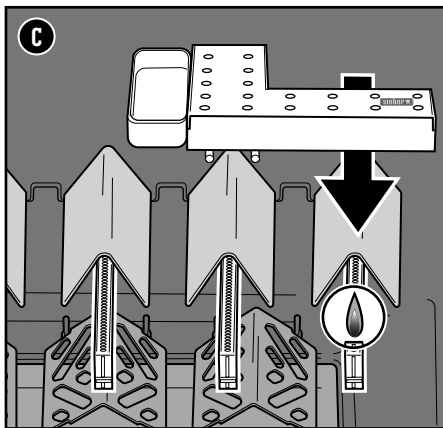
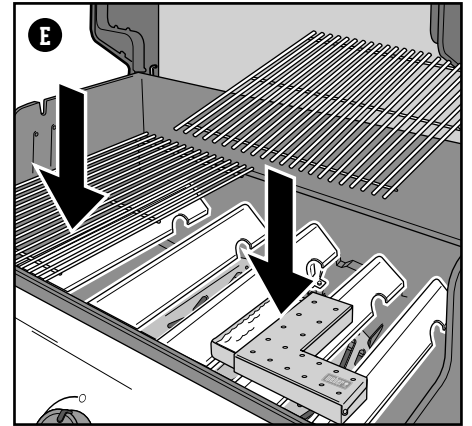
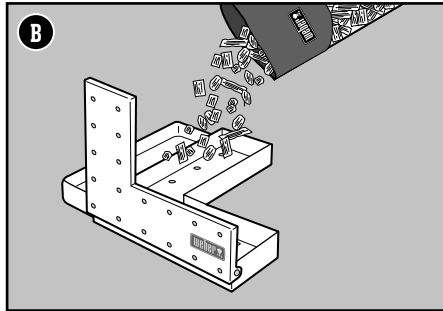
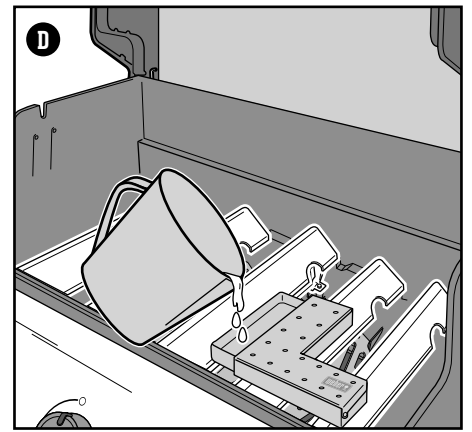
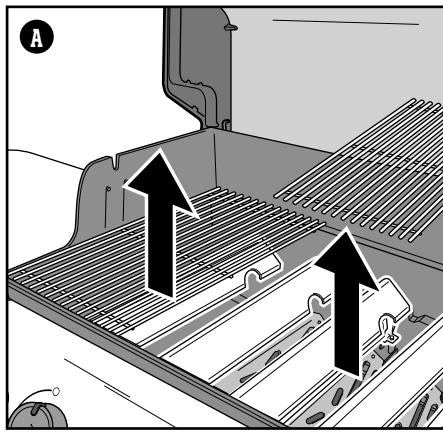

⚠ DANGER Do not use any flammable fluid or combustible products in the smoker to ignite the wood chips. This will cause serious bodily injury.

⚠ WARNING: Do not remove hot components from the grill while in use.

⚠ WARNING: Never use wood that has been treated or exposed to chemicals.

⚠ Always avoid soft, resinous woods like pine, cedar, and aspen.

	APPLE FIRESPIKE	CHERRY FIRESPIKE	PECAN FIRESPIKE	HICKORY FIRESPIKE	MESQUITE FIRESPIKE
	✓	✓	✓		
	✓	✓	✓	✓	
	✓	✓	✓	✓	✓
			✓		✓
			✓	✓	✓
	✓	✓			

Extra on the Side

WEBER CRAFTED Grill Locker

This feature is only available on select models.

The side storage area (A) is ideal for storing accessories and grillware.

Adjustable condiment basket keeps smaller items close at hand.

Always make sure the rubber mat is in place to protect surfaces.

Storage Hooks

Use the double-sided hooks on the side of the cabinet (B) for convenient storage of cooking grates on the outside of the grill. Additional hooks on the inside of the cabinet store the WEBER CRAFTED spacer grate, which can be used with WEBER CRAFTED Outdoor Kitchen Collection grillware..

Note: Do not place hot cooking grates on storage hooks.

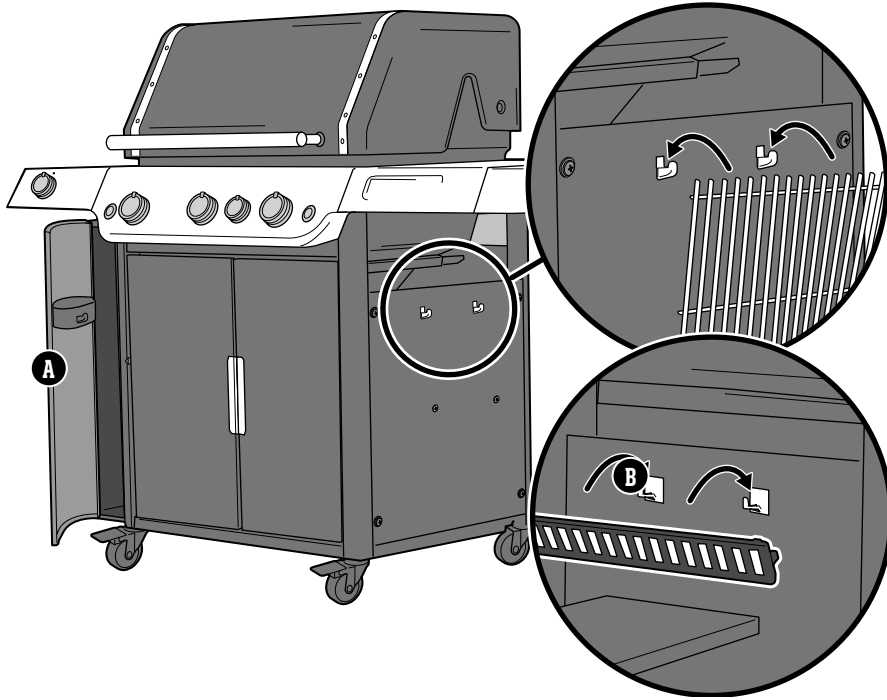

More Cooking Space

Using the Expandable Top Cooking Grate

Use it as a warming rack to keep food warm (A) or unfold it when you need a secondary cooking surface. To unfold, lift the front half of the grate slightly and rotate outward (B). For storage, fold the grate and lift the entire grate from the cookbox (C). Hang the grate vertically on the back edge of the cookbox. Use heat-resistant mitts or gloves when adjusting rack.

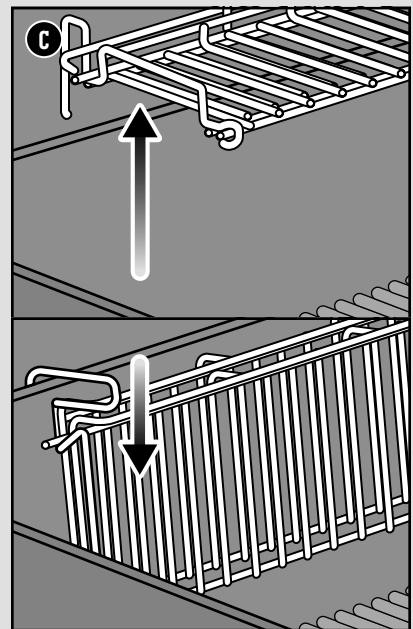
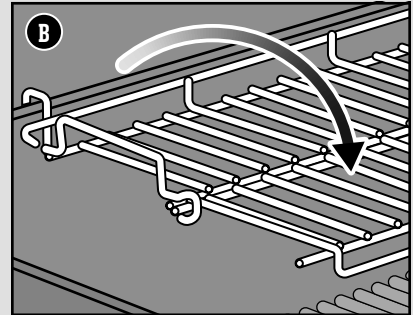
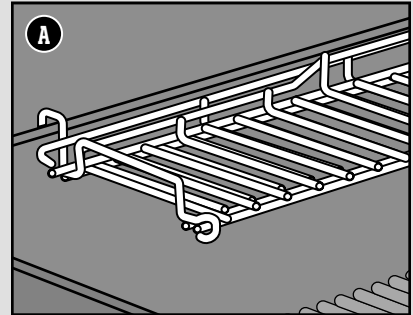

Grilling at Night

This feature is only available on select models.

Using the Grill Lighting

To activate the grill light press the awake button. The grill light has a tilt sensor that will turn on the light if the grill lid is opened and turn off the light when the grill lid is closed. If the lid is left open or closed for more than 30 minutes, the grill light will automatically deactivate. To turn the light back on, press the awake button.

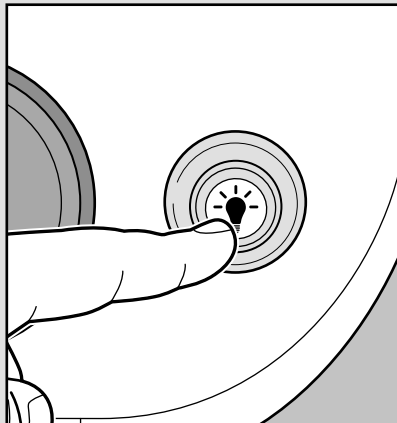
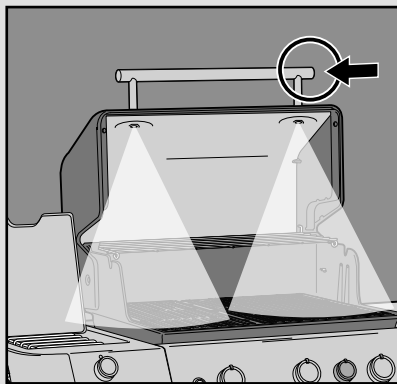

Using the Lighted Control Knobs

The burner control knobs light up with the push of a button. To turn on or off, simply push the power button located on the right side of the control panel.

Cleaning and Maintenance

Cleaning the Inside of the Grill

Over time, the performance of your grill can diminish if it has not been maintained properly. Low temperatures, uneven heat, and food sticking to cooking grates are all signs that cleaning and maintenance are overdue. When your grill is off and cool, start by cleaning the inside, from the top down. A thorough cleaning is recommended at least twice a year. Consistent use may require quarterly cleanings.

Cleaning the Lid

From time to time you may notice 'paint-like' flakes on the inside of the lid. During use, grease and smoke vapors slowly change into carbon and deposit on the inside of your lid. These deposits will eventually peel, and look very similar to paint. These deposits are non-toxic, but the flakes could fall onto your food if you do not clean the lid regularly.

- 1) Brush the carbonized grease from the inside of the lid with a stainless steel bristle grill brush (A). To minimize further build-up, the inside of the lid can be wiped with a paper towel after grilling while the grill is still warm (not hot).

Cleaning the Cooking Grates

If you have been cleaning your cooking grates as recommended, the debris on your grates should be minimal.

- 1) With grates installed, brush the debris off your cooking grate with a stainless steel bristle grill brush (B).
- 2) Take the grates out and set aside.

Cleaning the FLAVORIZER BARS

FLAVORIZER BARS catch drippings that smoke and sizzle, adding flavor to your food. Any drippings that are not vaporized by the FLAVORIZER BARS are funneled away from the burners. This helps prevent flare-ups inside of your grill, and protects the burners from getting clogged.

- 1) Scrape the FLAVORIZER BARS with a plastic scraper (C).
- 2) If necessary, brush the FLAVORIZER BARS with a stainless steel bristle grill brush.
- 3) Remove FLAVORIZER BARS and set aside.

Cleaning the Burners

Two areas on the burners that are key to optimum performance are the ports (small raised openings running along the length of the burners) and the spider/insect screens on the ends of the burner. Keeping these areas clean is essential for safe operation.

Cleaning the Burner Ports

- 1) Use a clean stainless steel bristle grill brush to clean the outside of the burners by brushing across the top of the burner ports (D).
- 2) When cleaning the burners, avoid damaging the ignition electrode by carefully brushing around it (E).

Cleaning the Spider Screens

- 1) Locate the ends of the burners on the underside of the control panel where they meet the valves.
- 2) Clean the spider/insect screens on each of the burners using a soft bristle brush (F).

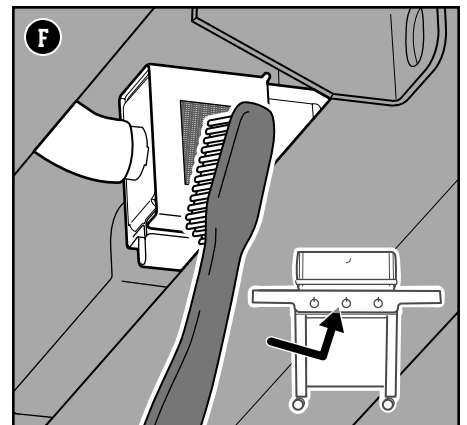
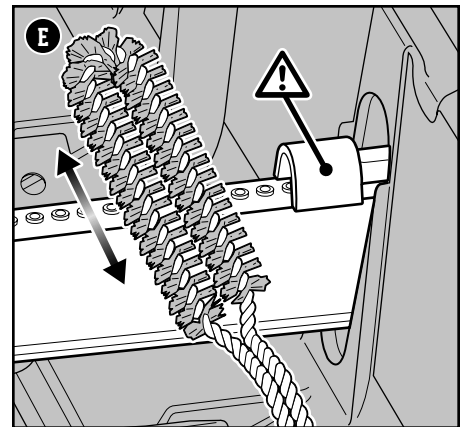
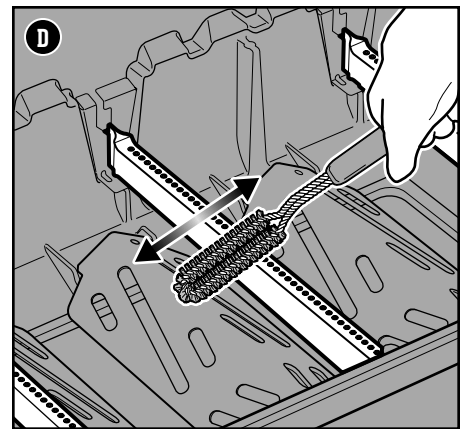
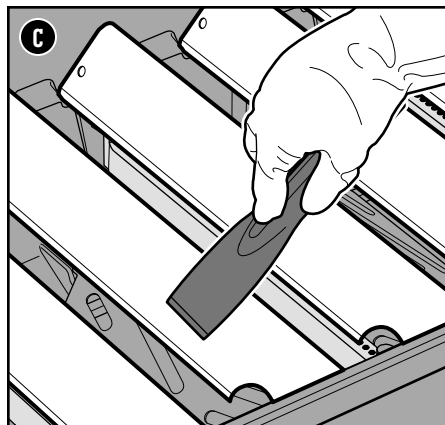
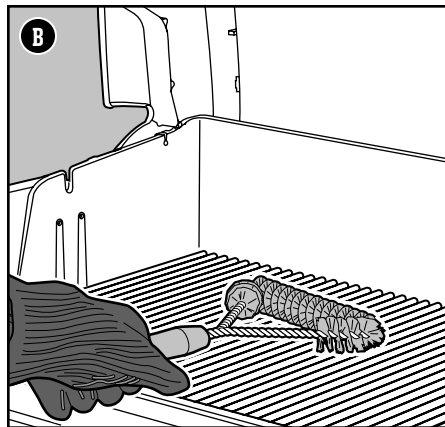
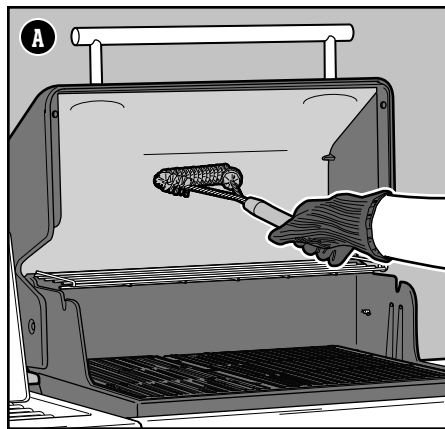

⚠ **WARNING:** Turn your grill off and wait for it to cool before thoroughly cleaning.

⚠ **WARNING:** Over time, the development of rough surfaces can form on the FLAVORIZER BARS. Wearing gloves is recommended when handling. Do not clean FLAVORIZER BARS or cooking grates in a sink, dishwasher, or self-cleaning oven.

⚠ **WARNING:** When cleaning the burners, never use a brush that has already been used to clean the cooking grates. Never put sharp objects into the burner port holes.

⚠ **CAUTION:** Do not place any grill components onto the side tables as they may scratch the paint or stainless steel surfaces.

⚠ **CAUTION:** Do not use any of the following to clean your grill: abrasive stainless steel polishes or paints, cleaners that contain acid, mineral spirits or xylene, oven cleaner, abrasive cleansers (kitchen cleansers), or abrasive cleaning pads.

MAIN BURNER(S) or SIDE BURNER WILL NOT IGNITE

SYMPTOM

• Main burners or side burner do(es) not ignite when following the electronic ignition instructions in the “Operation” section of this owner’s manual.

CAUSE

There is a problem with gas flow.

SOLUTION

If any burner does not ignite, the first step is to determine if there is gas flowing to the burner(s). To check this, follow the instructions below for “Lighting Your Barbecue with a Long-Reach Lighter.”

If burner lighting IS NOT successful, follow the “GAS FLOW” troubleshooting suggestions on the next page.





There is a problem with the electronic ignition system.

If any burner does not ignite, the first step is to determine if there is gas flowing to the burner(s). To check this, follow the instructions below for “Lighting Your Barbecue with a Long-Reach Lighter.”





If burner lighting IS successful, follow the instructions for “Checking the Components of the Electronic Ignition System.”

Lighting Your Grill with a Long-Reach Lighter

Using a Long-Reach Lighter or Long Match to Determine if there is Gas Flow to the Main Burners

- 1) Open the grill lid.
- 2) Check that all burner control knobs (including side burner control knob) are in the off  position. Check by pushing in and turning knobs clockwise.
Note: It is important that all burner control knobs are in the off  position before turning on the LPG cylinder.
- 3) Turn gas supply on by turning cylinder valve anti-clockwise or by moving regulator lever to the on position depending on your regulator/cylinder connection.
- 4) Begin with the burner furthest to the left. Insert lit long-reach lighter down through the cooking grates, past the FLAVORIZER bars and next to the burner **(A)**.
- 5) Push the burner control knob in and slowly turn it anti-clockwise toward the start/high  position.
- 6) Check that the burner is lit by looking through the cooking grates and through the cutout in the FLAVORIZER bar.
- 7) If the burner does not ignite within 4 seconds, turn burner control knob to the off  position and wait five minutes to allow the gas to clear before attempting to light the burner again. If repeated attempts fail, follow the gas flow troubleshooting instructions on the next page.
- 8) If the burner ignites, the problem lies in the ignition system. Follow the instructions for “Checking the Components of the Electronic Ignition System”.

Using a Long-Reach Lighter or Long Match to Determine if there is Gas Flow to the Side Burner

- 1) Open the side burner lid.
- 2) Check that all burner control knobs (including side burner control knob) are in the off  position. Check by pushing in and turning knobs clockwise.
Note: It is important that all burner control knobs are in the off  position before turning on the LPG cylinder.
- 3) Turn gas supply on by turning cylinder valve anti-clockwise or by moving regulator lever to the on position depending on your regulator/cylinder connection.
- 4) Hold lit long-reach lighter by the side burner **(B)**.
- 5) Push the side burner control knob in and slowly turn it anti-clockwise toward the start/high  position.
- 6) Check that the side burner is lit. The side burner flame may be difficult to see on a bright sunny day.
- 7) If the side burner does not ignite within 4 seconds, turn side burner control knob to the off  position and wait five minutes to allow the gas to clear before attempting to light the burner again. If repeated attempts fail, follow the gas flow troubleshooting instructions on the next page.
- 8) If the burner ignites, follow the instructions for “Checking the Components of the Electronic Ignition System”.

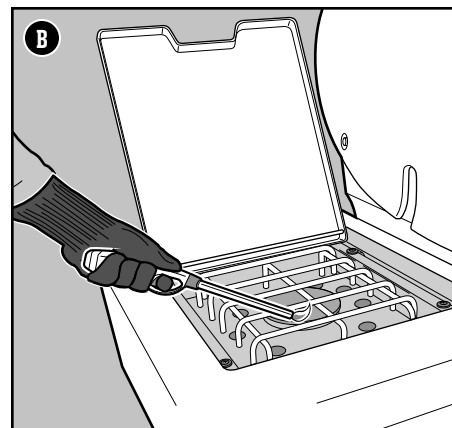
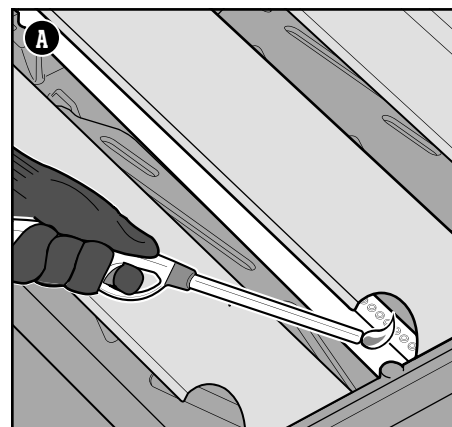
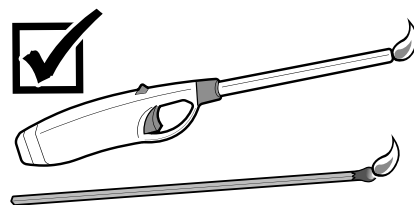

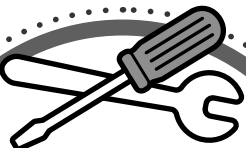

REPLACEMENT PARTS

To obtain replacement parts, contact the local retailer in your area or log onto weber.com.

GAS FLOW

SYMPTOM

- Barbecue does not reach desired temperature or heats unevenly.
- One or more of the burners fail to ignite.
- Flame is low when burner is on high position.
- Flames do not run the whole length of the burner.
- Burner flame pattern is erratic.

CAUSE

SOLUTION

Some countries have regulators with a "flow limiting device" that has been activated. This safety feature built into the regulator restricts the gas flow in the event of a gas leak. You can inadvertently activate this safety feature without having a gas leak. This typically occurs when you turn on the gas at the LPG cylinder and one or more of the control knobs are not in the off position. It may also occur if you turn on the LPG cylinder too quickly.

Reset the "flow limiting device" by closing the LPG cylinder valve and turning all the burner control knobs to the off \bigcirc position. Wait five minutes to allow accumulated gas to dissipate, then ignite the barbecue again following the instructions in the "Operation" section.

The LPG cylinder is low or empty.

Refill LPG cylinder.

Fuel hose is bent or kinked.

Straighten fuel hose.

Burner ports are dirty.

Clean burner ports. Refer to "Cleaning the Burner Ports."

SYMPTOM

- Gas is smelled in conjunction with burner flames that appear yellow and lazy.

CAUSE

SOLUTION

Spider screens on the burners are obstructed.

Clean spider screens. Refer to "Cleaning the Spider Screens" in the Product Care section. Also refer to the illustrations and information in this section about proper flame pattern and spider screens.

SYMPTOM

- The smell of gas and/or a light hissing sound.

CAUSE

SOLUTION

The internal rubber seal in the LPG cylinder valve could be damaged.

Inspect the rubber seal for damage. If damaged, return LPG cylinder to local retailer.

Proper Burner Flame Pattern

The burners in your grill were factory set for the correct air and gas mixture. When the burners are performing correctly, you will see a specific flame pattern. The tips may occasionally flicker yellow (A), with a descending light blue (B) to dark blue flame (C).

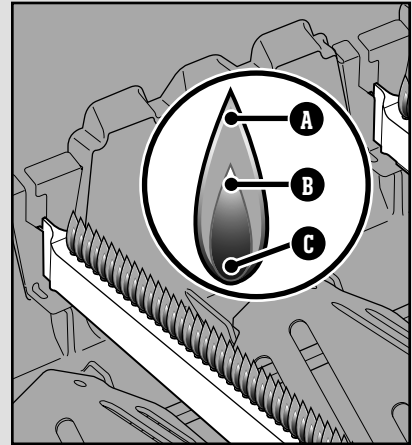

Spider Screens

The combustion air openings of the burners (D) are fitted with stainless steel screens to prevent spiders and other insects from spinning webs and building nests inside the burners. Additionally, dust and debris can accumulate on the outside of the spider/insect screen and obstruct the oxygen flow to the burners.

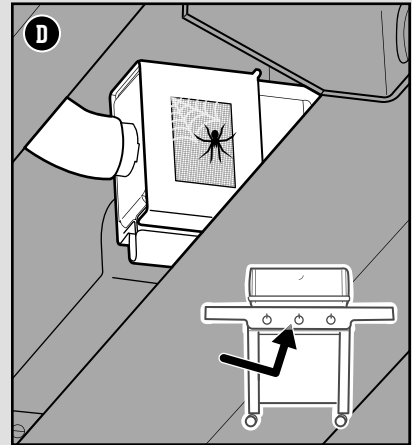

⚠ WARNING: Do not attempt to make any repair to gas carrying, gas burning, ignition components or structural components without contacting Weber-Stephen Products LLC, Customer Service Department.

⚠ WARNING: Failure to use genuine Weber-Stephen parts for any repair or replacement will void all warranty protection.

⚠ CAUTION: The burner tube openings must be positioned properly over the valve orifices.

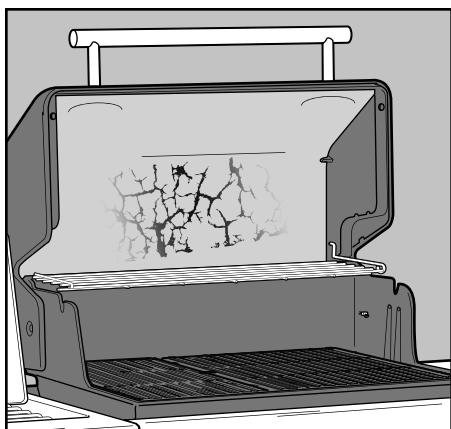

GREASY GRILL (Peeling Paint & Flare-Ups)

SYMPTOM

• Inside of lid appears to have the appearance of peeling paint.

CAUSE

The flakes you see are accumulated cooking vapors that have turned into carbon.

SOLUTION

This happens over time after repeated use of your grill. This is not a defect. Clean the lid. Refer to the "Product Care" section.

SYMPTOM

• Experiencing flare-ups when grilling or preheating.

CAUSE

There is leftover food from the previous meal.

SOLUTION

Always preheat the grill on the highest setting for 10 to 15 minutes.

The inside of the grill needs to be cleaned thoroughly.

Follow the steps in the "Cleaning and Maintenance" section to clean the grill inside from the top down.

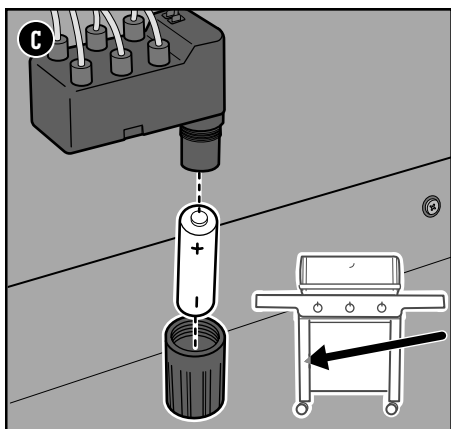

Checking the Components of the Electronic Ignition System

When pressing the ignition button you should hear a ticking sound. If you cannot hear the ticking sound, check the battery, then check the wires.

Checking the Battery

There are three potential issues with the battery that supplies the power to your ignition module that need to be checked:

- 1) Some batteries have a plastic protective wrap around them. (Do not confuse this plastic with the battery label.) Check that this plastic wrap is removed.
- 2) Confirm that the battery is installed correctly (C).
- 3) If the battery is old, replace it with a new battery.

Checking the Wires

There are two potential trouble spots that need to be checked:

- 1) Check that the ignition wires are connected securely to the terminals on the ignition button under the control panel.
- 2) Make sure the ignition wires are properly attached to the ignition module. The wire terminals are color coded to correspond with the terminals on the ignition module. The number of wires will vary per model.

CALL CUSTOMER SERVICE

If you are still experiencing any problems, contact the Customer Service Representative in your area using the contact information on weber.com.

335 Igniter Module Wire Chart

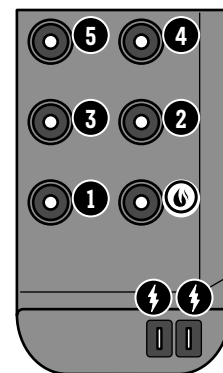
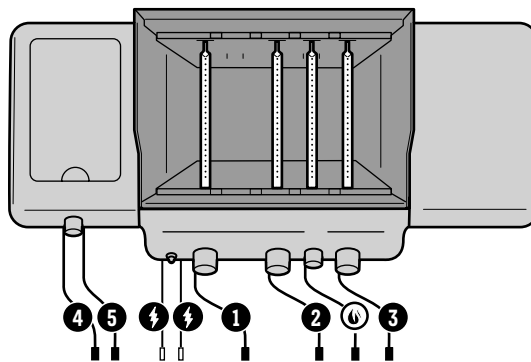

435 Igniter Module Wire Chart

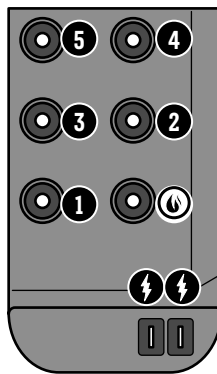
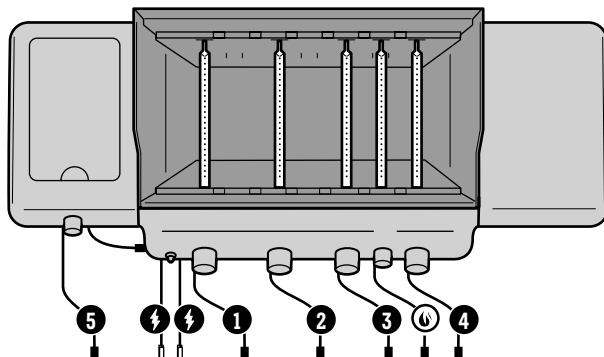

Checking the Ground Wire

Models 425s and 435 have a ground wire connected to the manifold bracket. This is visible from beneath the control panel (D):

- 1) Check that the ground wire is properly secured with a screw.

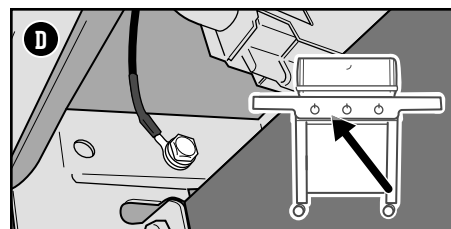

LOSS OF POWER

SYMPTOM

• **WEBER CONNECT module and control knobs lights do not turn on.**

CAUSE

SOLUTION

Wires are disconnected.

Check that all of the wires are connected securely to the terminals on the back of the WEBER CONNECT module and to the control board under the side table. Refer to the "WEBER CONNECT Wire Chart".

Power cord is disconnected.

Check that the power cord is plugged in to the port beneath the side table and to the wall outlet. Check that the switch beneath the side table is turned on. Refer to "Check the Power Cord".

The fuse has blown.

If the grill will still not power on after you have completed the above checks, it is likely that the fuse has blown. For instructions on how to replace the grill's fuse, refer to "Fuse Replacement".

Alternative external power bank may be depleted.

If you are using an optional external power bank, sold separately, disconnect it from the control board and check the manufacturer's operating guide for information on recharging. Refer to "Connecting an External Power Bank".

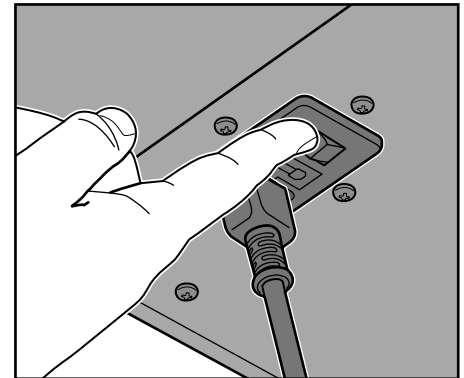
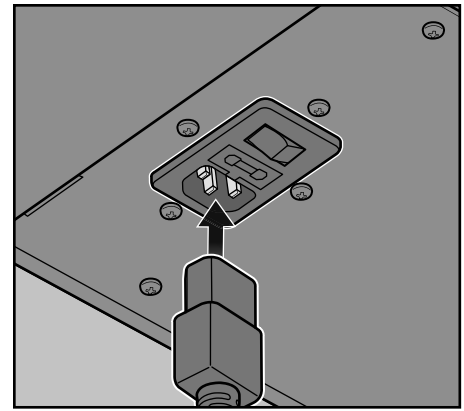

WEBER CONNECT IS EXPERIENCING CONNECTIVITY ISSUES

SYMPTOM

• **Bluetooth® is having trouble maintaining connectivity or pairing with a smart device.**

CAUSE

SOLUTION

Bluetooth® is a short range signal only.

When the WEBER CONNECT module is on, it is ready to pair. Make sure that Bluetooth® on the smart device is turned on and that the device is near the grill.

Bluetooth® has already paired to another smart device.

If the Bluetooth® indicator light is on but is not flashing, it means that it is already paired to a smart device. Turn off Bluetooth® on any smart device that you do not wish to have paired to the grill.

SYMPTOM

• **Wi-Fi is having trouble maintaining connectivity with a Wi-Fi network.**

CAUSE

SOLUTION

Grill is out of range of the Wi-Fi network signal.

In order to successfully connect your smart device to your local Wi-Fi network, your grill must be within range of your Wi-Fi router. If your attempts to connect have been unsuccessful, try moving the grill within range of the Wi-Fi router or adding a signal extender for a stronger signal.

ERROR CODE APPEARS ON DISPLAY

SYMPTOM

• **During start-up or barbecuing, an error code appears on the digital display.**

CAUSE

SOLUTION

The WEBER CONNECT module is a device that is sensitive to certain external factors. Variations in power supply or radio frequency may affect operation.

Contact the Customer Service Representative in your area using the contact information on weber.com.

Replacing Batteries for the Grill Lighting

Use alkaline batteries only. Do not mix old and new batteries or different types of batteries (standard, alkaline, or rechargeable). If you do not plan to use the grill for a month or more, remove the batteries.

- 1) Close the lid. Locate the battery housing on the side of the lid handle and unscrew the cap **(A)**. Do not change batteries with the lid open.
- 2) Remove the battery sleeve.
- 3) Replace three size C batteries **(B)**.
- 4) Line up graphic indicators **(C)** on the sleeve and handle as you reinstall the sleeve. Tighten cap.

NOTE: Periodically wipe the lenses with a damp cloth to keep the lights illuminating brightly.

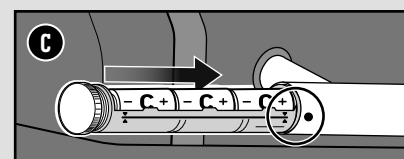
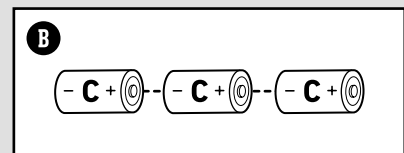
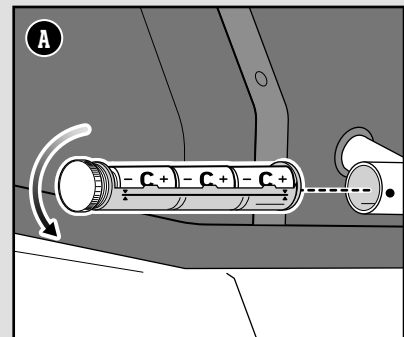

Fuse Replacement

If your WEBER CONNECT module is non-responsive even after securing all electrical connections, it is possible that the grill's fuse has blown. The grill's power supply utilizes a cartridge fuse. This simple and inexpensive part can be easily replaced with the following instructions:

CAUTION: *Only use the properly sized and rated fuse when replacing. Failure to do so will void your warranty. The correct fuse is:*

1.6A

250V

5x20mm

Fast blow

1. Make sure that the grill is completely cool, then power off and unplug the grill from the power source **(A)**.
2. The fuse is installed inside the fuse holder located on the underside of the side table. Use a flathead screwdriver to gently pry open the fuse holder and remove the fuse **(B)**.

NOTE: *WEBER recommends replacing the fuse if there is suspicion of failure.*

3. Install a new fuse into the fuse holder and reinstall the fuse holder into the power module **(C)**.

CAUTION: *Make sure the fuse holder is fully installed and closed before operating your grill.*

4. Plug in, power on the switch to allow the module to run.

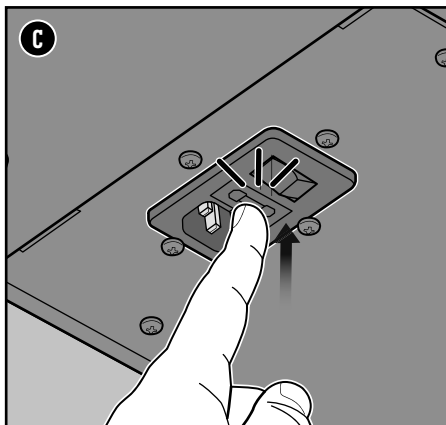
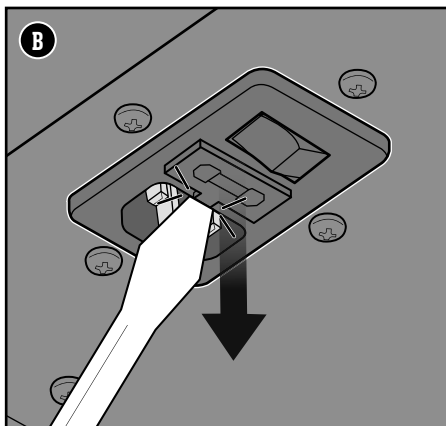
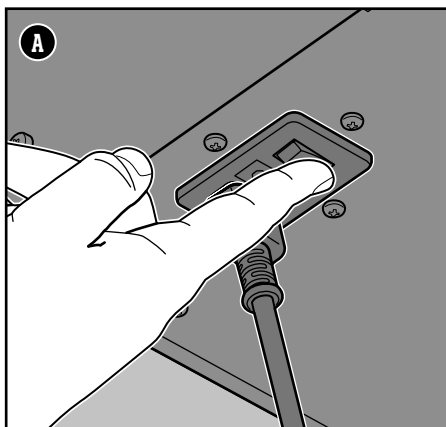

Auxiliary Power Input

Connecting an External Power Bank

As an alternative to using an AC wall outlet to power the WEBER CONNECT Module during your cook, you can instead connect an external rechargeable power bank, sold separately.

The power bank should have a minimum capacity of 10,000 mA hours with a 5 volt USB-A connector. Due to the low power draw of the Genesis Smart grill, when using a rechargeable power bank, you must use the USB-A port on the power bank to the USB-C input on the grill using a USB-A to USB-C cable, sold separately.

The shelf under the side table can accept a power bank with a maximum dimension of 4" wide x 7" deep x 1.25" high.

The WEBER CONNECT module will draw power automatically from the power bank if AC power is lost or unplugged. The power supply switch only controls the current from the wall outlet to the grill.

- 1) Using a USB-A to USB-C cable, connect the cable to the USB-A port on the power bank (A).
- 2) Remove the silicone dust cap from the control board. Connect the cable to the USB-C port on the control board (B).
- 3) Confirm the power bank is on.
- 4) Place the power bank on the small shelf beneath the side table (C).

Refer to the manufacturer's operating guide for instructions on fully charging the power bank.

Additional information regarding the use of a power bank:



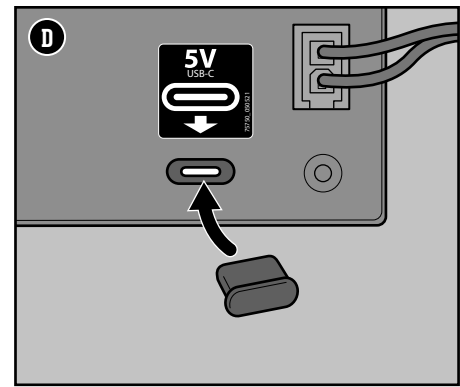
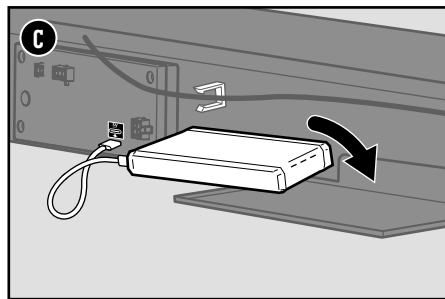
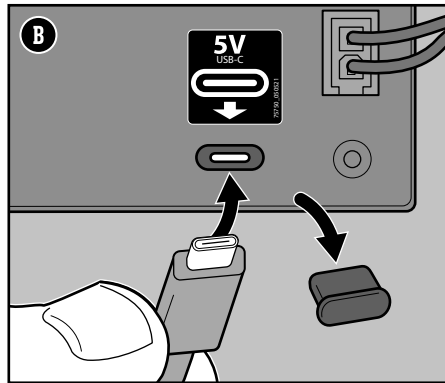
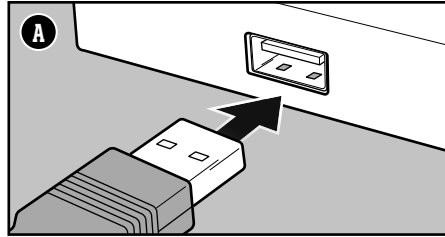
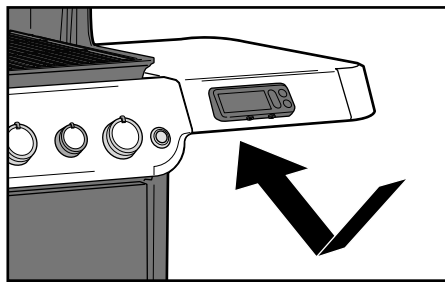

- Do not plug the power bank into an exterior outlet while it is connected to the grill.
- Disconnect the power bank from the grill and bring it indoors after use. Reinsert the silicone dust cap over the USB-C port on the control board (D).
- The power bank will not supply power to the burner igniters. Refer to "Checking the Components of the Electronic Ignition System".
- The USB-C connector on the control board is for input power only and does not output power.
- The USB-C connector on the control board is not for data transmission.
- Do not store the power bank outside.
- Fully recharge the power bank before every use. The battery level of the power bank is not monitored by the grill.
- Use only if outdoor temperature is between 10°F (-12°C) to 100°F (38°C) unless the power bank is rated for higher and/or lower temperature conditions. Follow the manufacturer's operating guidelines.

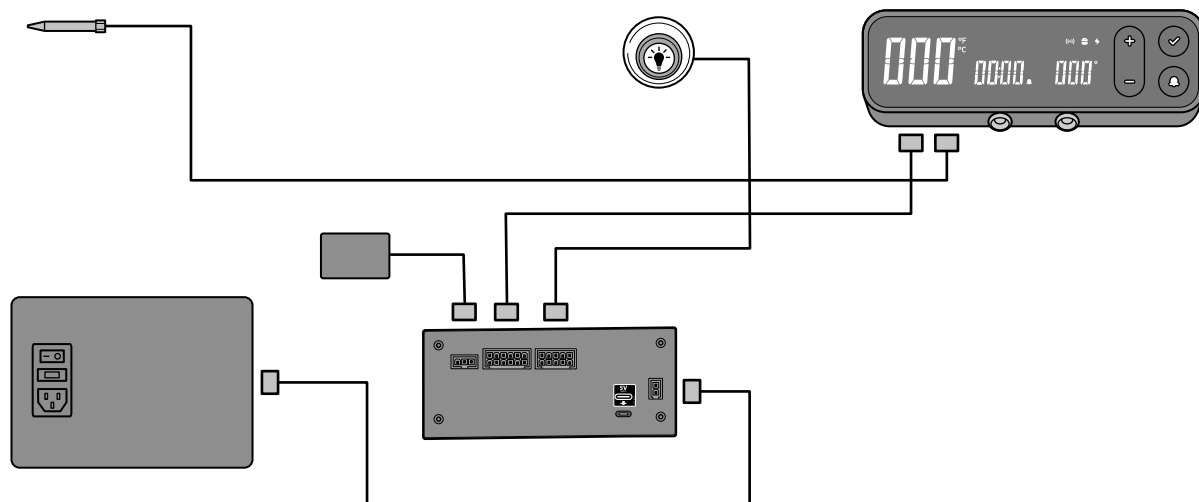

WEBER CONNECT Wire Chart



Barbecuing Guide

Type	Thickness/Weight	Approximate Total Barbecue Time
 RED MEAT		
Steak New York strip, porterhouse, rib-eye, T-bone, and filet mignon (tenderloin)	19 mm thick	4 to 6 minutes direct high heat
	25 mm thick	6 to 8 minutes direct high heat
	50 mm thick	14 to 18 minutes sear 6 to 8 minutes direct high heat, then 8 to 10 minutes indirect high heat
Flank Steak	0.68 to 0.90 kg, 19 mm thick	8 to 10 minutes direct medium heat
Ground Beef Patty	19 mm thick	8 to 10 minutes direct medium heat
Tenderloin	1.3 to 1.8 kg	45 to 60 minutes 15 minutes direct medium heat, then 30 to 45 minutes indirect medium heat
 PORK		
Bratwurst: fresh	85 g link	20 to 25 minutes direct low heat
Chop: boneless or bone in	19 mm thick	6 to 8 minutes direct high heat
	31 to 38 mm thick	10 to 12 minutes sear 6 minutes direct high heat, then 4 to 6 minutes indirect high heat
Ribs: baby back, spareribs	1.3 to 1.8 kg	1½ to 2 hours indirect medium heat
Ribs: country-style, bone in	1.3 to 1.8 kg	1½ to 2 hours indirect medium heat
Tenderloin	0.454 kg	30 minutes sear 5 minutes direct high heat, then 25 minutes indirect medium heat
 POULTRY		
Chicken Breast: boneless, skinless	170 to 226 g	8 to 12 minutes direct medium heat
Chicken Thigh: boneless, skinless	113 g	8 to 10 minutes direct medium heat
Chicken Pieces: bone in, assorted	85 to 170 g	36 to 40 minutes 6 to 10 minutes direct low heat, then 30 minutes indirect medium heat
Chicken, Whole	1.8 - 2.2 kg	1 to 1¼ hours indirect medium heat
Cornish Game Hen	0.68 - 0.90 kg	60 to 70 minutes indirect medium heat
Turkey: whole, unstuffed	4.5 - 5.4 kg	2 to 2½ hours indirect medium heat
 SEAFOOD		
Fish, Fillet, or Steak: halibut, red snapper, salmon, sea bass, swordfish, and tuna	6.3 to 12.7 mm thick	3 to 5 minutes direct medium heat
	25 - 31 mm thick	10 to 12 minutes direct medium heat
	0.454 kg	15 to 20 minutes indirect medium heat
Fish, Whole	1.36 kg	30 to 45 minutes indirect medium heat
Shrimp	42.5 g	2 to 4 minutes direct high heat
 VEGETABLES		
Asparagus	12.7 mm in diameter	6 to 8 minutes direct medium heat
	in husk	25 to 30 minutes direct medium heat
Corn	husk removed	10 to 15 minutes direct medium heat
	shiitake or button	8 to 10 minutes direct medium heat
Mushroom	portobello	10 to 15 minutes direct medium heat
	halved	35 to 40 minutes indirect medium heat
Onion	12.7 mm slices	8 to 12 minutes direct medium heat
	whole	45 to 60 minutes indirect medium heat
Potato	12.7 mm slices	9 to 11 minutes parboil 3 minutes, then 6 to 8 minutes direct medium heat

The cuts, thicknesses, weights, and barbecuing times above are meant to be guidelines. Factors such as altitude, wind, and outside temperature can affect cooking times. Two rules of thumb: Barbecue steaks, fish fillets, boneless chicken pieces, and vegetables using the direct method for the time given on the chart (or to the desired doneness), turning food once halfway through barbecuing time. Barbecue roasts, whole poultry, bone-in poultry pieces, whole fish and thicker cuts using the indirect method for the time given on the chart (or until an instant-read thermometer registers the desired internal temperature). Cooking times for beef and lamb are to medium doneness unless otherwise noted. Before carving, let roasts, larger cuts of meat, and thick chops and steaks rest for 5 to 10 minutes after cooking. The internal temperature of the meat will rise by 5 to 10 degrees during this time.

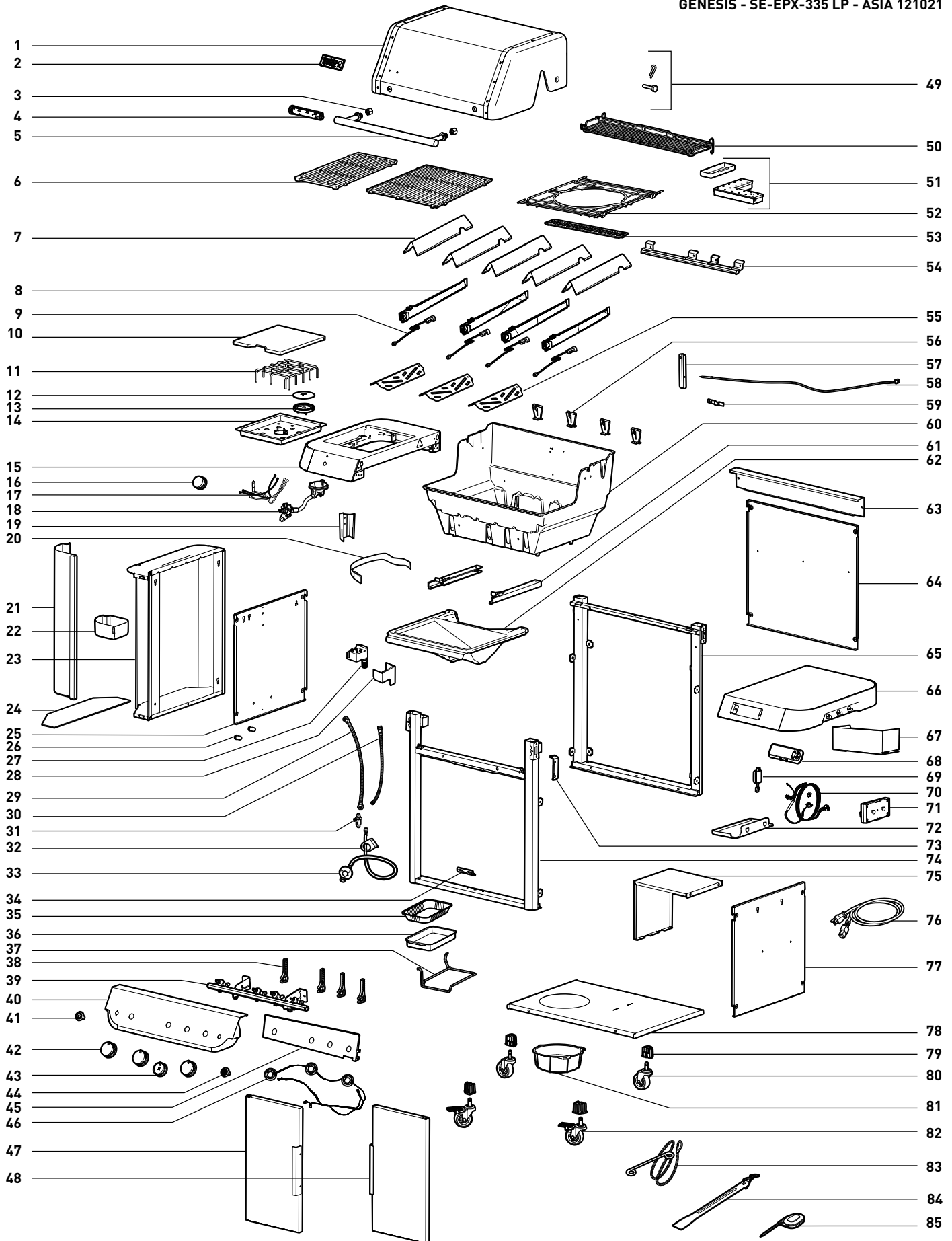

GENESIS SE-SPX-435

GENESIS - SE-SPX-435 LP - ASIA 121021

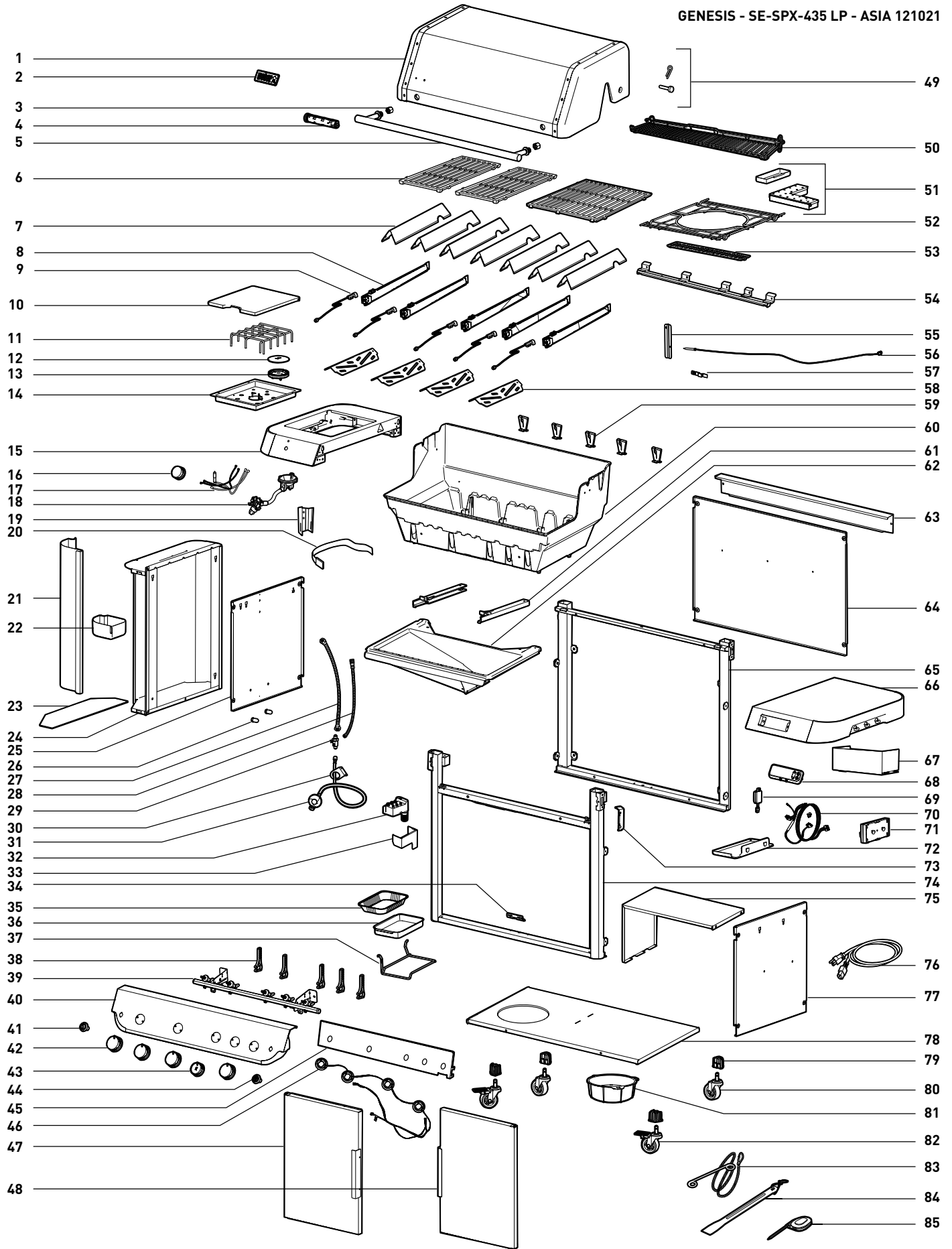

GENESIS SE-EPX-335 JAPAN

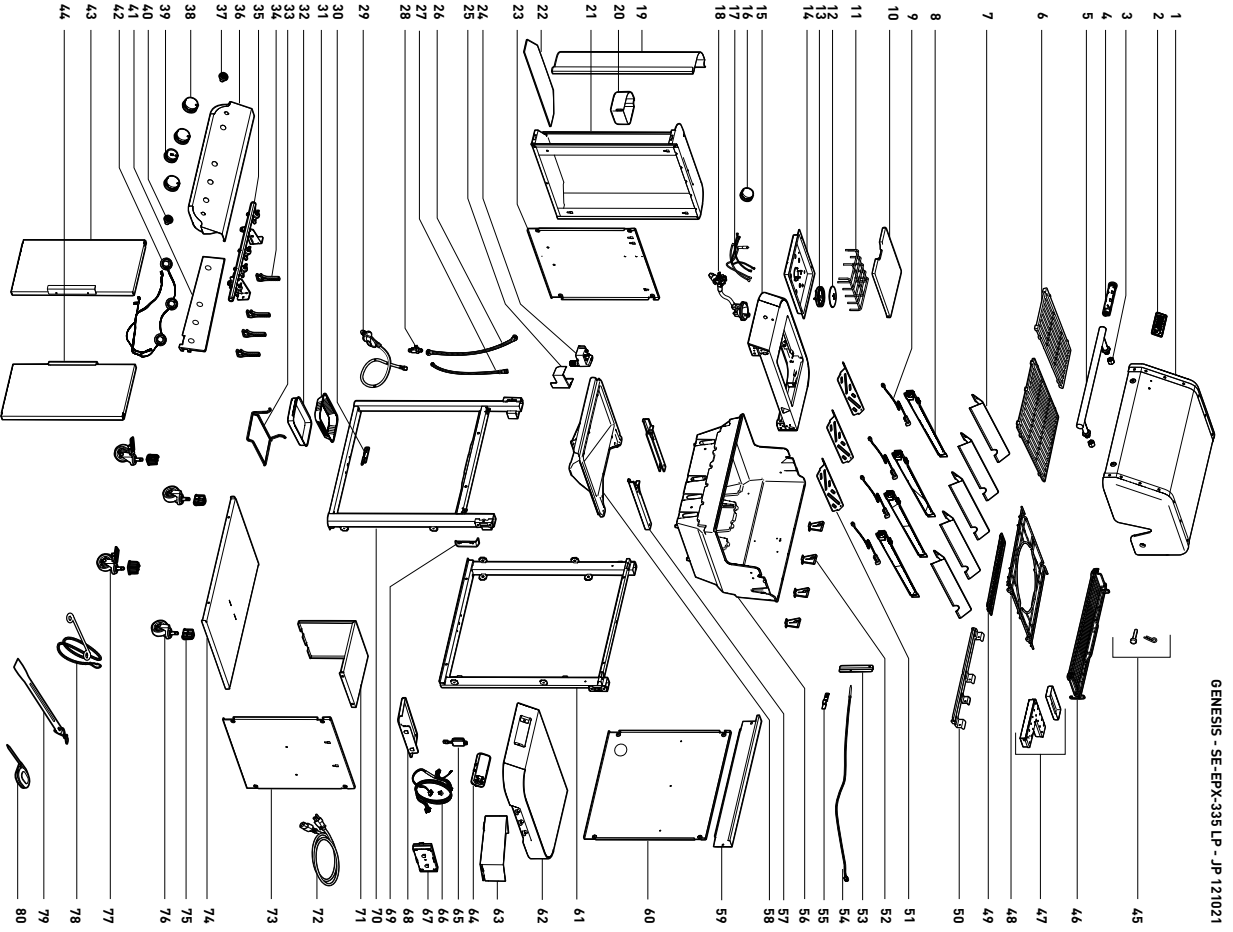

GENESIS SE-SPX-435 JAPAN

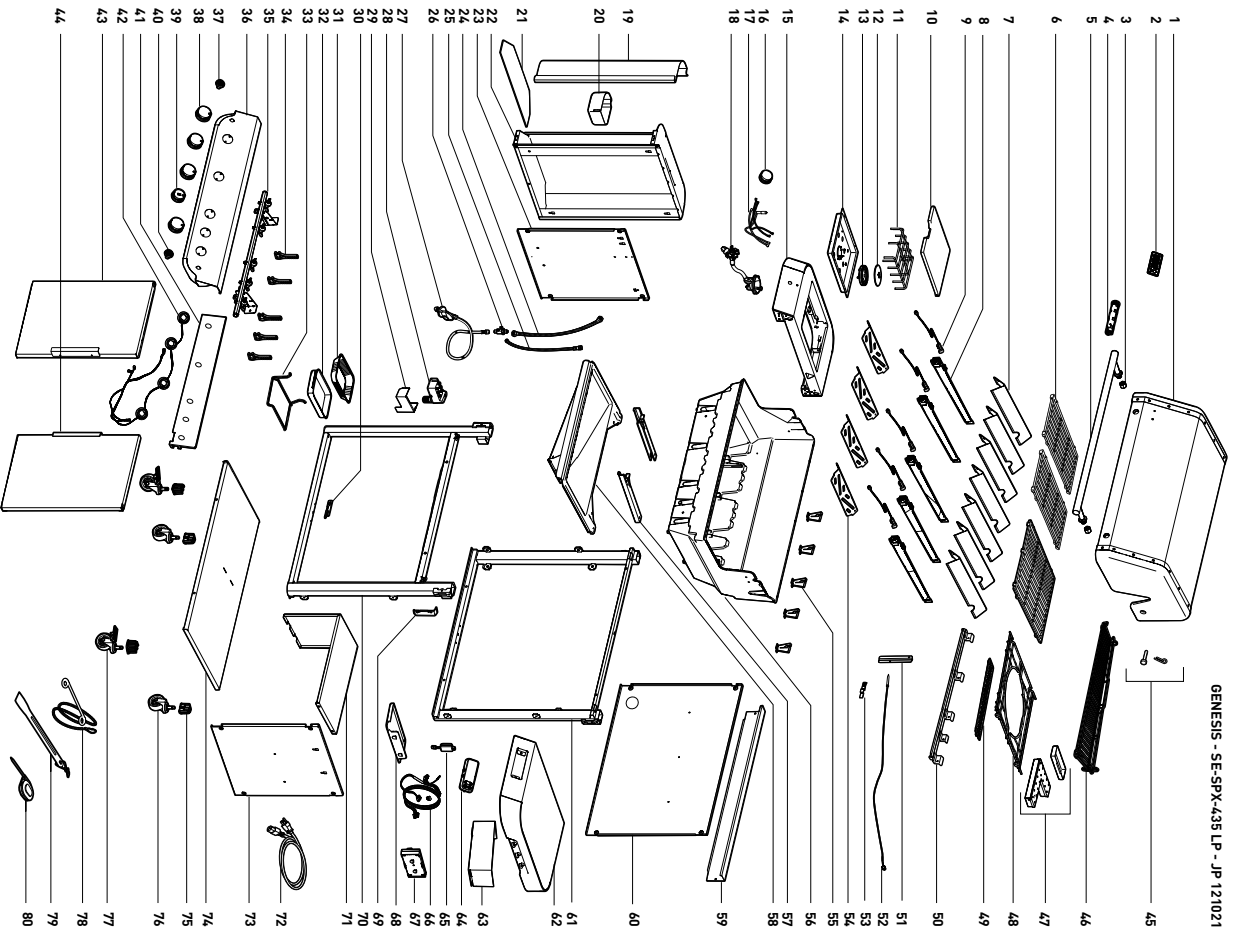



Manufacturer:

Weber-Stephen Products LLC

1415 S. Roselle Road
Palatine, IL 60067-6266
USA

Importer:

Weber-Stephen Products (EMEA) GmbH

Franklinstraße 28/29
10587 Berlin
Tel: (+49) 307554184-0

Serial Number

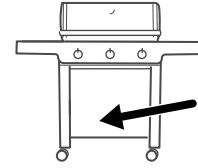

Write your grill's serial number in the above box for future reference. The serial number is on the data label located on the inside of the cabinet.

Model: GEN1

AUSTRIA

Weber-Stephen Österreich GmbH
+43 (0)7 242 89 0135
service-at@weber.com

BELGIUM

Weber-Stephen Products Belgium Sprl
+32 15 28 30 99
service-be@weber.com

CHILE

Weber-Stephen Chile SpA.
+01 56 2-3224-3936

CZECH REPUBLIC

Weber-Stephen CZ & SK spol. s r.o.
+42267312973
info-cz@weberstephen.com

DENMARK

Weber-Stephen Nordic ApS
+45 99 36 30 10
service-dk@weber.com

FRANCE

Weber-Stephen France SAS
+33 0810 19 32 37
service-fr@weber.com

GERMANY

Weber-Stephen Deutschland GmbH
+49 (0) 30 219 0710
service-de@weber.com

ICELAND

Jarn & Gler Wholesale EHF
+354 58 58 900

INDIA

Weber-Stephen Barbecue Products India Pvt. Ltd.
080 42406666
customercare@weberindia.com

ISRAEL

D&S Imports
+972 392 41119
info@weber.co.il

ITALY

Weber-Stephen Products Italia Srl
+39 0444 367 911
service-it@weber.com

NETHERLANDS

Weber-Stephen Holland B.V.
+31 (0) 513 4 333 22
service-nl@weber.com

POLAND

Weber-Stephen Polska Sp. z o.o.
+48 22 392 04 69
info-pl@weberstephen.com

RUSSIA

Weber-Stephen Vostok LLC
+7 495 956 63 21
info.ru@weberstephen.com

SOUTH AFRICA

Weber-Stephen Products (South Africa) Pty Ltd.
+27 11 454 2369
info@weber.co.za

SPAIN

Weber-Stephen Ibérica SRL
+34935844055
service-es@weber.com

SWITZERLAND

Weber-Stephen Schweiz GmbH
+41 52 24402 50
service-ch@weber.com

UNITED ARAB EMIRATES

Weber-Stephen Deutschland GmbH, Dubai Branch
+971 4 454 1626
info@weberstephen.ae

UNITED KINGDOM

Weber-Stephen Products (UK) Ltd.
+44 (0)203 630 1500
service-uk@weber.com

USA

Weber-Stephen Products LLC
847 934 5700
support@weberstephen.com

For Republic of Ireland, please contact:
Weber-Stephen Products (U.K.) Limited.

For other eastern European countries, such as ROMANIA,
SLOVENIA, CROATIA, or GREECE, please contact:
Weber-Stephen Deutschland GmbH.

For Baltic states, please contact:
Weber-Stephen Nordic ApS.

weber.com



Apple and the Apple logo are trademarks of Apple Inc., registered in the U.S. and other countries. App Store is a service mark of Apple Inc. Android and Google Play are trademarks of Google Inc.

The Bluetooth® word mark and logos are registered trademarks owned by Bluetooth SIG, Inc. and any use of such marks by Weber-Stephen Products LLC is under license. Other trademarks and trade names are those of their respective owners.

© 2022 Designed and engineered by Weber-Stephen Products LLC, 1415 S. Roselle Road, Palatine, Illinois 60067 USA.