

GENESIS



SMART

SE-EPX-335 • SE-SPX-335

SE-EPX-435 • SE-SPX-435

NG Owner's Manual



REGISTER TODAY

We are so glad that you have joined us on the journey to barbecuing greatness. Register your barbecue and gain access to fun and engaging WEBER information, including tips, tricks and how to get the most out of your barbecuing experience.

Keep this Owner's Manual for future reference, thoroughly read through it, and if you have any questions please contact us today.

30643

051222
enAU, enNZ

Important Safety Information

DANGER, WARNING, and CAUTION statements are used throughout this Owner's Manual to emphasise critical and important information. Read and follow these statements to help ensure safety and prevent property damage. The statements are defined below.

- ⚠ **DANGER:** Indicates a hazardous situation which, if not avoided, *will result in death or serious injury.*
- ⚠ **WARNING:** Indicates a hazardous situation which, if not avoided, *could result in death or serious injury.*
- ⚠ **CAUTION:** Indicates a hazardous situation which, if not avoided, *could result in minor or moderate injury.*

⚠ DANGER

If you smell gas:

- Shut off gas to the appliance.
- Extinguish any open flame.
- Open lid.
- If odour continues, keep away from the appliance and immediately call your gas supplier or the emergency fire services.

⚠ WARNING

- Do not store or use gasoline or other flammable liquids or vapours in the vicinity of this or any other appliance.
- A cylinder not connected for use shall not be stored in the vicinity of this or any other appliance.

USE OUTDOORS ONLY.

READ THE INSTRUCTIONS BEFORE USING THE APPLIANCE.

NOTICE TO INSTALLER: These instructions must be left with the consumer.

NOTICE TO CONSUMER: Retain these instructions for future reference.

Installation and Assembly

- ⚠ **DANGER:** This barbecue is not intended to be installed in or on recreational vehicles or boats.
- ⚠ **WARNING:** Do not use this barbecue unless all parts are in place and the barbecue was properly assembled according to the assembly instructions.
- ⚠ **WARNING:** Do not build this model of barbecue in any built-in or slide-in construction.
- ⚠ **WARNING:** Do not modify this appliance. LP gas is not natural gas. The conversion or attempted use of natural gas in a LP gas unit or LP gas in a natural gas unit is unsafe and will void your warranty.
- ⚠ **WARNING:** Do not route the ten-foot hose under a deck. The hose must be visible.
- **WE RECOMMEND THAT THE INSTALLATION OF THIS NATURAL GAS BARBECUE BE PERFORMED BY A PROFESSIONAL.**
- Confirm that the branch supply line from the house to the barbecue is properly installed before using the barbecue.
- The installation of the barbecue must conform with the requirements of AS/NZS 5601 and the local authority – gas or electricity, etc.
- Any parts sealed by the manufacturer must not be altered by the user.

Operation

- ⚠ **DANGER:** Only use the barbecue outdoors in a well-ventilated area. Do not use in a garage, building, breezeway, tent, any other enclosed area, or beneath overhead combustible construction.
- ⚠ **DANGER:** Do not use the barbecue in any vehicle or in any storage or cargo area of any vehicle. This includes, but is not limited to, cars, trucks, station wagons, mini-vans, sport utility vehicles, recreational vehicles, and boats.
- ⚠ **DANGER:** Do not use the barbecue within 61 cm (24 inches) of combustible materials. This includes the top, bottom, back and sides of the barbecue.
- ⚠ **DANGER:** Keep the cooking area clear of flammable vapours and liquids such as petrol, alcohol, etc., and combustible materials.
- ⚠ **DANGER:** This appliance must be kept away from flammable materials during use. Do not use or store flammable materials in or near this appliance. Do not spray aerosols in the vicinity of this appliance while it is in operation.
- ⚠ **DANGER:** Do not put a barbecue cover or anything flammable on, or in the storage area under the barbecue while it is in operation or is hot.
- ⚠ **DANGER:** Should a grease fire occur, turn off all burners and leave lid closed until fire is out.
- ⚠ **WARNING:** Accessible parts may be very hot. Keep young children away.
- ⚠ **WARNING:** The use of alcohol, prescription drugs, non-prescription drugs, or illegal drugs may impair the consumer's ability to properly and safely assemble, move, store, or operate the barbecue.
- ⚠ **WARNING:** Never leave the barbecue unattended during pre-heating or use. Exercise caution when using this barbecue. The entire cookbox gets hot when in use.
- ⚠ **WARNING:** Do not move the appliance during use.
- ⚠ **WARNING:** Keep any electrical supply cord and the fuel supply hose away from any heated surfaces.
- ⚠ **WARNING:** Do not place articles on or against this appliance.
- ⚠ **CAUTION:** This product has been safety-tested and is only certified for use in a specific country. Refer to country designation located on outside of box.
- Do not use charcoal, briquettes or lava rock in the barbecue.
- This natural gas barbecue is factory built to operate using natural gas only. Never attempt to operate your barbecue on gases other than the type specified on the barbecue rating plates.

Storage and/or Nonuse

- ⚠ **WARNING:** After a period of storage and/or nonuse, the barbecue should be checked for gas leaks and burner obstructions before use.
- Storage of the barbecue indoors is permissible only if the grill is disconnected from the gas supply.

Electrical Supply

- ⚠ **WARNING:** This appliance is not intended for use by persons (including children) with reduced physical, sensory or mental capabilities, or lack of experience and knowledge, unless they have been given supervision or instruction concerning use of the appliance by a person responsible for their safety.
- ⚠ **WARNING:** Children should be supervised to ensure that they do not play with the appliance.
- ⚠ **WARNING:** Only use the power supply unit provided with this appliance.
- ⚠ **WARNING:** This appliance incorporates an earth connection for functional purposes only.
- ⚠ **WARNING:** To protect against risk of electric shock, do not immerse cord or plugs in water or other liquid.
- ⚠ **WARNING:** Unplug from the outlet when not in use and before cleaning. Allow to cool before putting on or taking off parts.
- ⚠ **WARNING:** Do not operate any outdoor cooking gas appliance with a damaged cord or plug, or after the appliance malfunctions or has been damaged in any manner. Contact the Customer Service Representative in your area using the contact information on our web site. Log onto www.weber.com
- ⚠ **WARNING:** Do not let the cord hang over the edge of a table or touch hot surfaces.
- ⚠ **WARNING:** Do not use an outdoor cooking gas appliance for purposes other than intended.
- ⚠ **WARNING:** On connecting, first connect the plug to the outdoor cooking gas appliance and then plug the appliance into the outlet.
- ⚠ **WARNING:** Only use a Ground Fault Interrupter (GFI) protected circuit with this outdoor cooking gas appliance.
- ⚠ **WARNING:** Never remove the grounding plug or use with a two-prong adapter.
- ⚠ **WARNING:** Only use extension cords with a three-prong grounding plug, rated for the equipment's power, and approved for outdoor use with a W-A marking.
- Do not connect two or more extension cords together.



HELLO!

We are so glad that you have joined us on the journey to barbecuing happiness. Please take some time to read through this Owner's Manual to ensure that you are up and barbecuing quickly and easily. We want to be with you for the life of your barbecue, so please take just a couple of minutes to register your barbecue. When you sign up for a WEBER-ID as part of your registration, we will deliver special barbecue-related content just for you to enjoy.

So, come along and join us online, on your smart device or however else you'd like to stay in touch.

Thank you for choosing WEBER.

We are happy you are here.



Even your barbecue can update its status

1 DOWNLOAD THE FREE APP



3 CONNECT AND MONITOR

2 INSERT PROBE

4 PERFECT RESULTS

FEATURE	BENEFIT
REMOTE BARBECUE MONITOR	WI-FI AND BLUETOOTH® BARBECUE MONITORING Remote barbecuing access gives you the freedom to walk away and monitor the heat from your smart device.
STEP-BY-STEP BARBECUING	PERFECTLY BARBECUED FOOD... Know when it's time to flip, rest, and serve directly from your smart device. Receive notifications on everything from when it's time to flip food, to a countdown that displays when it's ready.
APP ENABLED FOOD THERMOMETERS	INSTANT FOOD STATUS READOUT View food temperature & doneness without lifting the lid. The food probes monitor doneness from beginning to end and will notify you via the app when it's time to flip, rest, and serve.
RECIPES & INSTRUCTIONS	WEBER RECIPES AND COOKING PROGRAMMES Weber recipes and cooking programmes that provide real time, step-by-step barbecuing instructions, specific to your cooking preference and cut of meat.
LED DISPLAY	DASHBOARD The LED display dashboard on your module is where you can visually check temperatures, receive notifications, view connectivity status, and check the status of your cooking session.



TABLE OF CONTENTS

- 2 Welcome to Weber
Important Safety Information
- 4 The Weber Promise
- 5 Product Features
GENESIS Smart Features
High Performance Barbecuing
- 6 Getting Started
Considerations for
Locating your Barbecue
Important Information about
Natural Gas & Gas Connections
Hose Connection
Leak Checking
Installing the Safety Tether to
Barbecue and Structure
- 12 Operation
The Very First Time You Barbecue
Every Time You Barbecue
Igniting the Barbecue
Using the sear zone
Igniting the Side Burner
Integrated WEBER CONNECT
Technology
Using the WEBER CONNECT Module
Food Temperature Probe Care
- 18 Tips and Hints
The Flame - Direct or Indirect
Discover What's Possible
Barbecuing Do's and Don'ts
Real Smoke Flavour
Extra on the Side
More Cooking Space
Barbecuing at Night
- 22 Product Care
Cleaning and Maintenance
- 24 Troubleshooting
- 30 Barbecuing Guide
- 31 Replacement Parts

The WEBER Promise

At WEBER, we pride ourselves on two things: making barbecues that last and providing a lifetime of excellent customer service.

Thank you for purchasing a WEBER product. Weber-Stephen Products LLC, 1415 S. Roselle Road, Palatine, Illinois 60067 ("WEBER") prides itself on delivering a safe, durable, and reliable product.

This is WEBER's Voluntary Warranty provided to you at no extra charge. It contains the information you will need to have your WEBER product repaired in the unlikely event of a failure or defect.

Pursuant to the Australia Consumer Law, the Owner has several rights in case the product is defective. Those rights include that the product is fit for purpose, acceptable in appearance and finish, free from defects and is safe and durable. These and other statutory rights remain unaffected by this warranty provision. In fact, this warranty grants additional rights to the Owner that are independent from statutory warranty provisions.

WEBER'S VOLUNTARY WARRANTY

WEBER warrants, to the purchaser of the WEBER product (or in the case of a gift or promotional situation, the person for whom it was purchased as a gift or promotional item), that the WEBER product is free from defects in material and workmanship for the period(s) of time specified below when assembled and operated in accordance with the accompanying Owner's Manual. (Note: If you lose or misplace your WEBER Owner's Manual, a replacement is available online at www.weber.com, or such country-specific website to which Owner may be redirected.) Under normal, private single family home or apartment use and maintenance, WEBER agrees within the framework of this warranty to repair or replace defective parts within the applicable time periods, limitations, and exclusions listed below. TO THE EXTENT ALLOWABLE BY APPLICABLE LAW, THIS WARRANTY IS EXTENDED ONLY TO THE ORIGINAL PURCHASER AND IS NOT TRANSFERABLE TO SUBSEQUENT OWNERS, EXCEPT IN THE CASE OF GIFTS AND PROMOTIONAL ITEMS AS NOTED ABOVE.

OWNER'S RESPONSIBILITIES UNDER THIS WARRANTY

To ensure trouble-free warranty coverage, it is important (but it is not required) that you register your WEBER product online at www.weber.com, or such country-specific website to which Owner may be redirected. Please also retain your original sales receipt and/or invoice. Registering your WEBER product confirms your warranty coverage and provides a direct link between you and WEBER in case we need to contact you.

The above warranty only applies if the Owner takes reasonable care of the WEBER product by following all assembly instructions, usage instructions, and preventative maintenance as outlined in the accompanying Owner's Manual, unless the Owner can prove that the defect or failure is independent of non-compliance with the above mentioned obligations. If you live in a coastal area, or have your product located near a pool, maintenance includes regular washing and rinsing of the exterior surfaces as outlined in the accompanying Owner's Manual.

Our goods come with guarantees that cannot be excluded under the Australian Consumer Law. You are entitled to a replacement or refund for a major failure and for compensation for any other reasonably foreseeable loss or damage. You are also entitled to have the goods repaired or replaced if the goods fail to be of acceptable quality and the failure does not amount to a major failure.

The benefits given under this Limited Warranty are in addition to other rights and remedies you have under the Australian Consumer Law in relation to this WEBER gas barbecue.

WARRANTY HANDLING / EXCLUSION OF WARRANTY

If you believe that you have a part which is covered by this Warranty, please contact WEBER Customer Service using the contact information on our website (www.weber.com, or such country-specific website to which Owner may be redirected). WEBER will, upon investigation, repair or replace (at its option) a defective part that is covered by this Warranty. In the event that repair or replacement are not possible, WEBER may choose (at its option) to replace the grill in question with a new grill of equal or greater value. WEBER may ask you to return parts for inspection, shipping charges to be pre-paid.

This WARRANTY lapses if there are damages, deteriorations, discolorations, and/or rust for which WEBER is not responsible caused by:

- Abuse, misuse, alteration, modification, misapplication, vandalism, neglect, improper assembly or installation, and failure to properly perform normal and routine maintenance;
- Insects (such as spiders) and rodents (such as squirrels), including but not limited to damage to burner tubes and/or gas hoses;
- Exposure to salt air and/or chlorine sources such as swimming pools and hot tubs/spas;
- Severe weather conditions such as hail, hurricanes, earthquakes, tsunamis or surges, tornadoes or severe storms.

The use and/or installation of parts on your WEBER product that are not genuine WEBER parts will void this Warranty, and any damages that result hereby are not covered by this Warranty. Any conversion of a gas grill not authorized by WEBER and performed by a WEBER authorized service technician will void this Warranty.

PRODUCT WARRANTY PERIODS

Cookbox:

12 years, no rust through/burn through
(2 years paint excluding fading or discoloration)

Lid assembly:

12 years, no rust through/burn through
(2 years paint excluding fading or discoloration)

Stainless steel burner tubes:

10 years, no rust through/burn through

Stainless steel cooking grates:

10 years, no rust through/burn through

Stainless steel FLAVORIZER BARS:

10 years, no rust through/burn through

Porcelain-enameled cast iron cooking grates:

10 years, no rust through/burn through

WEBER CONNECT Components:

3 years

All remaining parts:

5 years

DISCLAIMERS

APART FROM THE WARRANTY AND DISCLAIMERS AS DESCRIBED IN THIS WARRANTY STATEMENT, THERE ARE EXPLICITLY NO FURTHER WARRANTY OR VOLUNTARY DECLARATIONS OF LIABILITY GIVEN HERE WHICH GO BEYOND THE STATUTORY LIABILITY APPLYING TO WEBER. THE PRESENT WARRANTY STATEMENT ALSO DOES NOT LIMIT OR EXCLUDE SITUATIONS OR CLAIMS WHERE WEBER HAS MANDATORY LIABILITY AS PRESCRIBED BY STATUTE.

NO WARRANTIES SHALL APPLY AFTER THE APPLICABLE PERIODS OF THIS WARRANTY. NO OTHER WARRANTIES GIVEN BY ANY PERSON, INCLUDING A DEALER OR RETAILER, WITH RESPECT TO ANY PRODUCT (SUCH AS ANY "EXTENDED WARRANTIES"), SHALL BIND WEBER. THE EXCLUSIVE REMEDY OF THIS WARRANTY IS REPAIR OR REPLACEMENT OF THE PART OR PRODUCT.

IN NO EVENT UNDER THIS VOLUNTARY WARRANTY SHALL RECOVERY OF ANY KIND BE GREATER THAN THE AMOUNT OF THE PURCHASE PRICE OF THE WEBER PRODUCT SOLD.

YOU ASSUME THE RISK AND LIABILITY FOR LOSS, DAMAGE, OR INJURY TO YOU AND YOUR PROPERTY AND/OR TO OTHERS AND THEIR PROPERTY ARISING OUT OF THE MISUSE OR ABUSE OF THE PRODUCT OR FAILURE TO FOLLOW INSTRUCTIONS PROVIDED BY WEBER IN THE ACCOMPANYING OWNER'S MANUAL.

PARTS AND ACCESSORIES REPLACED UNDER THIS WARRANTY ARE WARRANTED ONLY FOR THE BALANCE OF THE ABOVE MENTIONED ORIGINAL WARRANTY PERIOD(S).

THIS WARRANTY APPLIES TO PRIVATE SINGLE FAMILY HOME OR APARTMENT USE ONLY AND DOES NOT APPLY TO WEBER GRILLS USED IN COMMERCIAL, COMMUNAL OR MULTI-UNIT SETTINGS SUCH AS RESTAURANTS, HOTELS, RESORTS, OR RENTAL PROPERTIES.

WEBER MAY FROM TIME TO TIME CHANGE THE DESIGN OF ITS PRODUCTS. NOTHING CONTAINED IN THIS WARRANTY SHALL BE CONSTRUED AS OBLIGATING WEBER TO INCORPORATE SUCH DESIGN CHANGES INTO PREVIOUSLY MANUFACTURED PRODUCTS, NOR SHALL SUCH CHANGES BE CONSTRUED AS AN ADMISSION THAT PREVIOUS DESIGNS WERE DEFECTIVE.

Weber-Stephen Products (Aust) Pty Ltd.
Level 1, 142-144 Fullarton Road
ROSE PARK SA 5067 AUSTRALIA
+61 8 8221 6111

WEBER New Zealand ULC
86 East Highbrook Drive
East Tamaki, Auckland 2013 NEW ZEALAND
+64 9 279 7133



**PROTECT
YOUR
INVESTMENT**

Shield your barbecue from the elements with a heavy-duty premium barbecue cover.

GENESIS Smart FEATURES

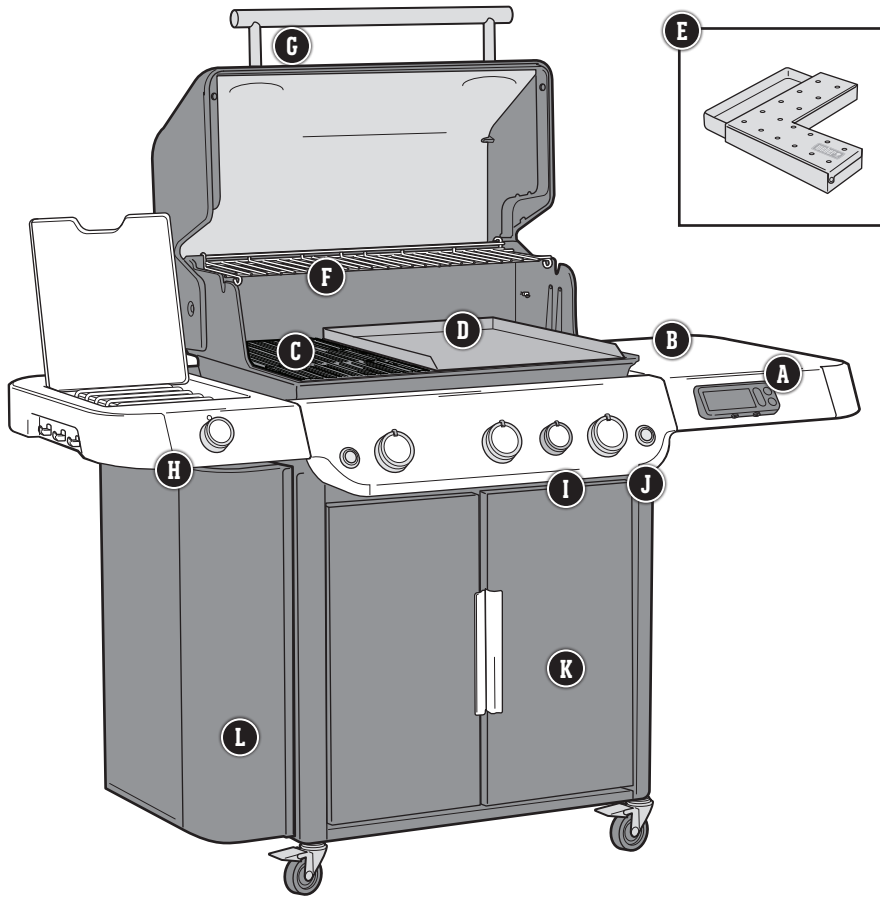

A WEBER CONNECT

Confidently tend to the barbecue and your guests while using the integrated WEBER CONNECT technology. This device monitors internal barbecue temperature and uses food temperature probes allowing you to monitor the temperature of your food. You can also monitor your barbecue from your smart device with the WEBER CONNECT app via Bluetooth® or Wi-Fi connection. One food temperature probe is included. Additional food probes are sold separately.

B Prep & Serve Table

Use the side tables to keep platters, seasonings, and tools within arm's reach. Hang your essential barbecuing tools on the hooks for easy access and organisation of your backyard workspace.

C WEBER CRAFTED Outdoor Kitchen Collection Cooking Grills and Frame

Your barbecue is Outdoor Kitchen Collection Ready with the included cooking grills and frame. Additional WEBER CRAFTED grillware sold separately.

D Flat Top

The Flat Top easily converts your grill so you can enjoy all of your flat-top favorites like pancakes, eggs, fajitas and smashed burgers. (Packaged separately)

E Genesis Smoker Box

Positioned beneath the cooking grills, the smoker box adds continuous smoke to your cooking session.

F Expandable Top Cooking Grills

Keeps food warm, or toasts buns, while the main course finishes barbecuing. Fold it out when you need a secondary cooking surface.

G Barbecue Lighting

Integrated with the lid handle, LED lights illuminate the cooking surface to keep barbecuing as the sun goes down.

H Side Burner

Use the side burner to simmer BBQ sauce or sauté veggies while the main course barbecues under the lid.

I Sear zone

The sear zone is designed to create an intense heat zone to quickly add sear marks to your meat.

J Lighted Control Knobs

With a push of a button, the control knobs light up to offer optimal control while night-time barbecuing.

K Barbecue Cabinet

The barbecue cabinet adds enclosed storage space for all of your essential barbecuing tools and accessories.

L WEBER CRAFTED Grill Locker

Convenient side storage makes it easy to access all of your WEBER CRAFTED grillware.

HIGH PERFORMANCE BARBECUING

The high performance barbecuing system sets the standard in the world of gas barbecuing, and lands Weber in a class of its own. This powerful barbecuing system is based on over 65 years of barbecuing experience, culinary expertise, and most importantly, the wants and needs of the people who matter most – our barbecuing community. Each component was uniquely designed for ease-of-use and to provide an unequaled satisfaction to your backyard barbecuing experience.

1 INFINITY Ignition



The Infinity Ignition is guaranteed to ignite. Rest assured that you'll be up-and-barbecuing the first time, every time.

2 Burners

The unique, tapered shape delivers a consistent gas flow from front to back. This provides ultimate heat distribution, ensuring that food barbecues evenly and consistently anywhere on the cooking grills.

3 FLAVORIZER BARS

Stainless Steel FLAVORIZER BARS are angled just right to catch drippings that smoke and sizzle, adding that irresistible smoky flavour that we all know and love to your food.

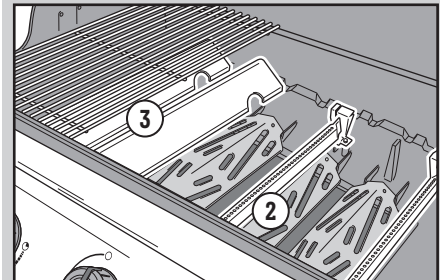

4 Grease Management System

Drippings that are not vapourised by the FLAVORIZER BARS are funnelled away from the burners into the disposable drip tray, located within the removable catch pan under the cook box. Simply remove the catch pan and replace the drip tray as needed.

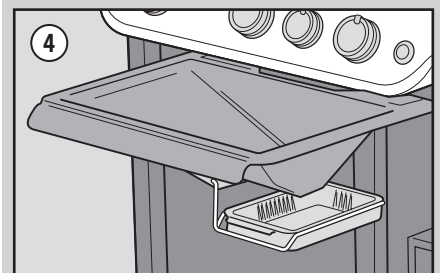

Some features listed are only available on select models.

The barbecues that are illustrated in this Owner's Manual may vary slightly from the model purchased.

Considerations for Locating your Barbecue

Any enclosure in which the appliance is used shall comply with one of the following:

- An enclosure with walls on all sides, but at least one permanent opening at ground level and no overhead cover (A).
- Within a partial enclosure that includes an overhead cover and no more than two walls (B).
- Within a partial enclosure that includes an overhead cover and more than two walls, the following shall apply (C):
 - (i) at least 25% of the total wall area is completely open; and
 - (ii) at least 30% of the remaining wall area is open and unrestricted.
- In the case of balconies, at least 20% of the total of the side, back and front wall areas shall be and remain open and unrestricted.

A

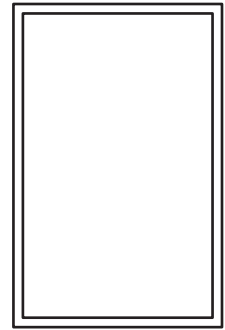
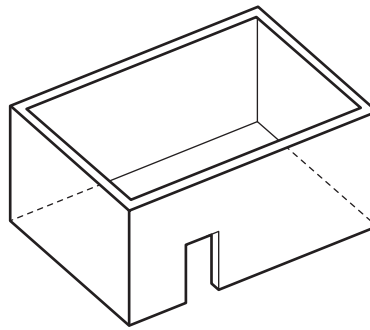

B

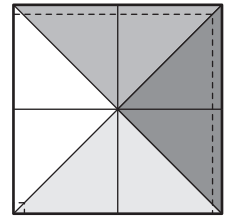
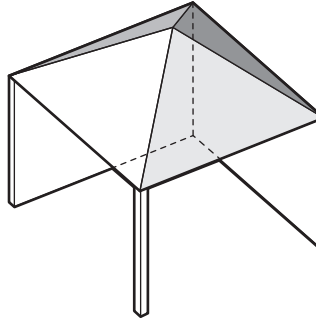

Both ends open

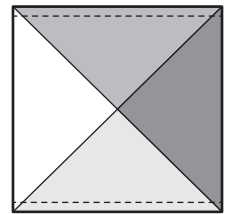
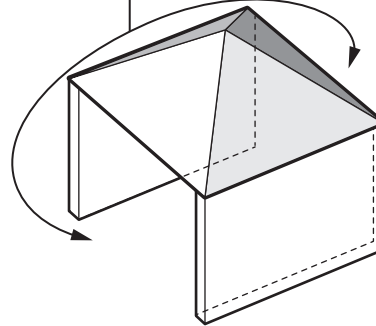

C

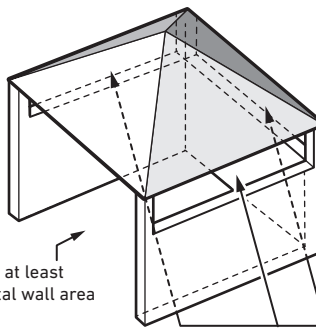

Open side at least 25% of total wall area

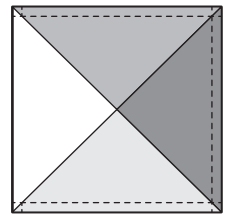

30% or more in total of the remaining wall area is open and unrestricted

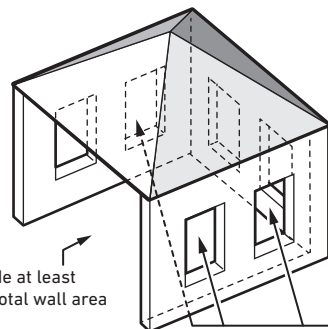

Open side at least 25% of total wall area

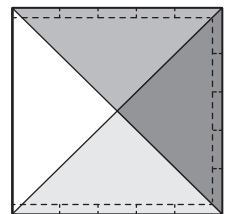

30% or more in total of the remaining wall area is open and unrestricted

△ IMPORTANT: This appliance shall only be used in an above ground open-air situation with natural ventilation, without stagnant areas, where gas leakage and products of combustion are rapidly dispersed by wind and natural convection.

Important Information about Natural Gas & Gas Connections

What is Natural Gas?

Natural gas (NG) is a combustible, gaseous mixture of simple hydrocarbon compounds, usually found in deep underground reservoirs formed by porous rock. It is a fossil fuel composed almost entirely of methane. Natural gas is delivered by your local utility through an underground pipeline system.

General Specifications

- The installation of the barbecue must conform with the requirements of AS/NZS 5601 and the local authority – gas or electricity, etc.
- Gas inlet connection - 1/2" BSP thread.
- Refer to data plate on barbecue for gas type, consumption, pressures and injector sizing details.
- Use only a 1.0 kPa natural gas regulator.
- The regulator specified for this installation is the **Maxitrol RV48LSM pressure regulator**.
- Use only AGA approved hose assemblies.
- The dust cover (plastic plug supplied with your barbecue) help keep the open end of the bayonet fitting clean while disconnected.

Hose and Regulator Requirements

- If the hose becomes worn or damaged, contact the Customer Service Representative in your area using the contact information on our website.

Pressure Testing the Gas Supply

Maxitrol regulators

To set nominal test point pressure of 1.0 kPa:

- On 335 models with a Maxitrol regulator fitted, turn three main burners to the start/high position.
- On 435 models with a Maxitrol regulator fitted, turn four main burners to the start/high position.

Adjust the regulator outlet pressure to 1.0 kPa.

Natural Gas Connection

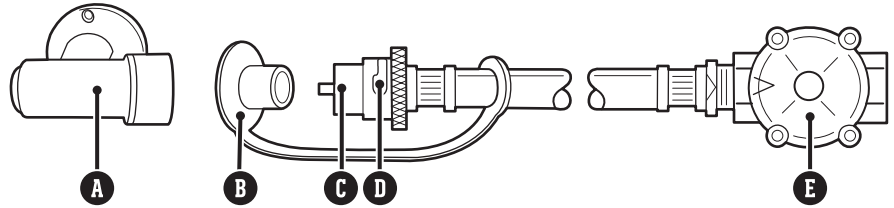

A Bayonet fitting B Dust cover C Male fitting D Plug groove E NG regulator

GENESIS NG Burner Valve Orifice Sizes & Consumption Data

Gas Category	BURNER VALVE ORIFICE SIZES		
	1.0 kPa	325s Models	425s Models
	Main Burners 1.75 mm	Main Burners 1.62 mm	
	Sear Burner 1.64 mm	Sear Burner 1.62 mm	
	335 Models	435 Models	Side Burner Models
	Main Burners 1.75 mm	Main Burners 1.62 mm	Side Burner 1.74 mm
	Sear Burner 1.64 mm	Sear Burner 1.62 mm	
TOTAL CONSUMPTION DATA			
325s Models	335 Models	425s Models	435 Models
57.5 Mj/h	69.5 Mj/h	63.5 Mj/h	75.5 Mj/h



FOIL PANS

Perfect for lining the catch pan to make cleanup convenient and easy.



BRUSH AND MOP

Look for a basting brush with heat-resistant silicone bristles and a long handle. A mop with long, cotton threads that sop up the thinner, vinegar-based sauces.

△ IMPORTANT: We recommend that you replace the gas hose assembly on your gas barbecue every five years. Some countries may have requirements that the gas hose be replaced within less than five years, in which case that country's requirement would take precedence.

For replacement hose, regulator, and valve assemblies, contact the Customer Service Representative in your area using the contact information on our web site. Log on to weber.com.

Hose Connection

Connect the Regulator to the Bulkhead

The hose and regulator needs to be properly connected to the bulkhead.

The regulator specified for this installation is the **Maxitrol RV48LSM pressure regulator**.

- 1) Remove the screw from behind the side panel that secures the bulkhead bracket (**A**).
- 2) Lift bulkhead bracket away from the side panel.
- 3) Fasten the regulator to the bulkhead fitting (**B**) by hand tightening first. Then, using two wrenches, tighten the regulator.
- 4) Reattach the bulkhead bracket to the side panel and secure with the screw (**C**).

*NOTE: Install the regulator in the proper position (**D**), with the body of the regulator parallel to the side panel, allowing for the bulkhead bracket to be fully secured to the side panel without interference.*

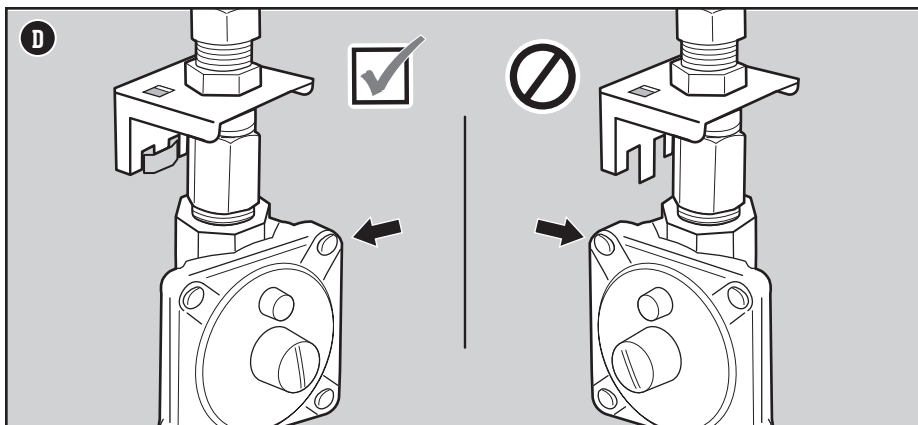
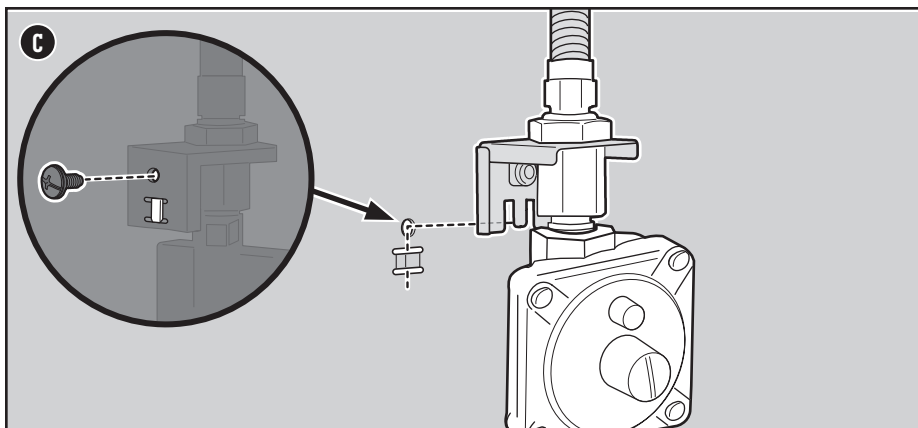
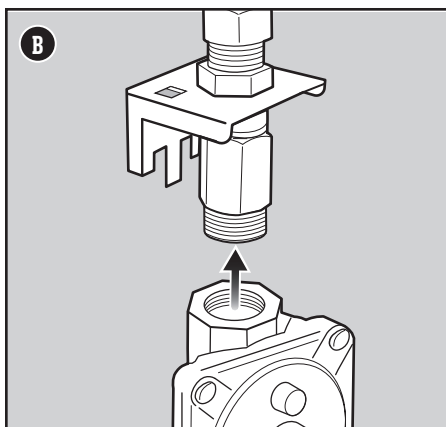
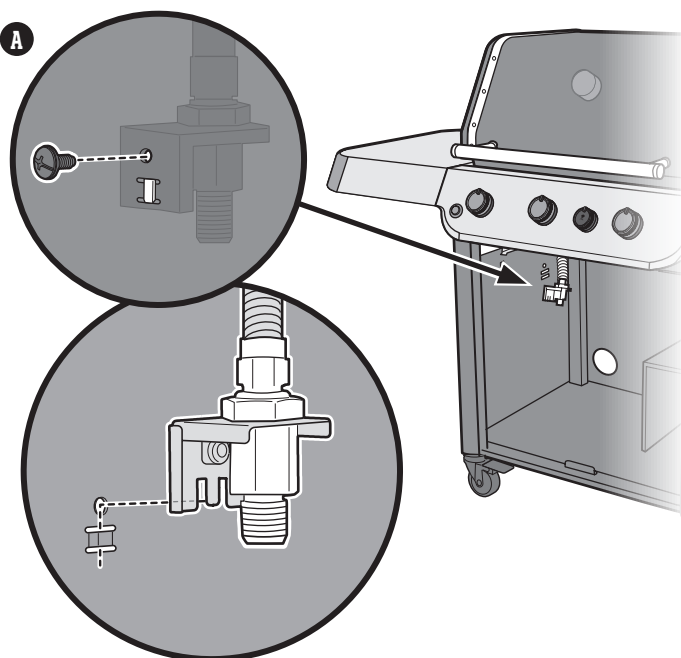

Connect the Hose to the Gas Supply

A bayonet fitting connects your barbecue to the gas supply. Gas will not flow unless the bayonet fitting is properly engaged.

- 1) Check that all burner control knobs are in the off  position. Check by pushing in and turning knobs clockwise (A).
- 2) Pass the gas hose through the opening in the rear panel (B).
- 3) Push male fitting of the hose into the socket, aligning plug groove with notch in socket (C).
- 4) Maintain pressure while turning plug 1/4 turn clockwise (D). If fitting does not engage or lock, repeat procedure. Proceed to "CHECKING FOR GAS LEAKS".

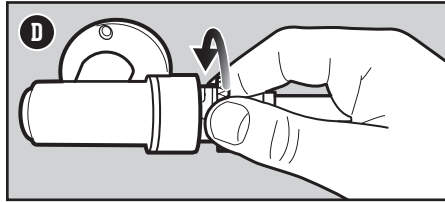
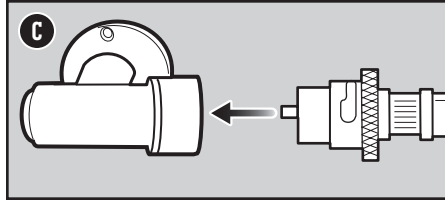
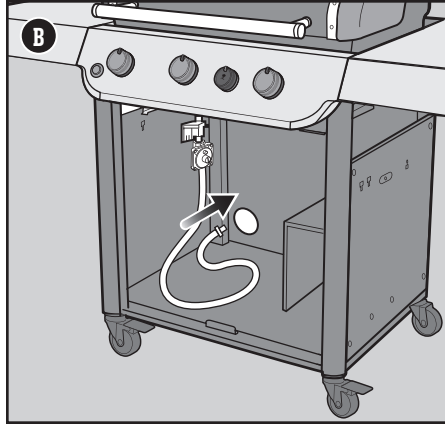
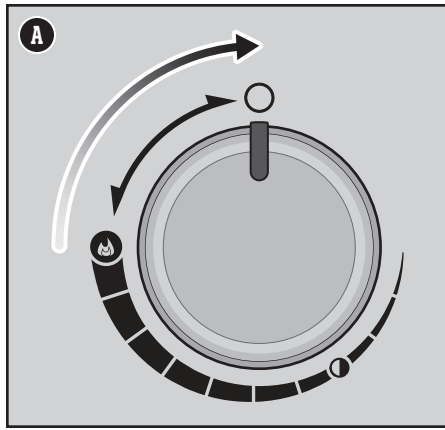

Leak Checking

What is a Leak Check?

Once the hose is properly connected, it is necessary to perform a leak check. A leak check is a reliable way to verify that gas is not escaping after you connect the hose to the gas supply.

Weber recommends performing a thorough leak check after assembly, as well as annually. The following fittings should be tested:

- Where the gas hose connects to the gas supply.
- Where the gas hose and regulator connect to the bulkhead.
- Where the bulkhead connects to the corrugated gas line.

Checking for Gas Leaks

- 1) Wet fittings shown **(A)** with a soap and water solution, using a spray bottle, brush or rag. You can make your own soap and water solution by mixing 20% liquid soap with 80% water; or, you can purchase leak check solution in the plumbing section of any hardware store.
- 3) If bubbles appear there is a leak:
 - a) If the leak is at the bayonet fitting **(B)**, turn off the gas. **DO NOT OPERATE THE BARBECUE.** Contact the Customer Service Representative in your area using the contact information on our website.
 - c) If the leak is at any fittings indicated in illustration **(C)**, re-tighten fitting with a wrench and recheck for leaks with soap and water solution. If leak persists, turn off the gas. **DO NOT OPERATE THE BARBECUE.**
 - d) If the leak is at any fittings indicated in illustration **(D)**, turn off the gas. **DO NOT OPERATE THE BARBECUE.**
- 4) If bubbles do not appear, leak checking is complete. Turn gas supply valve off and rinse connections with water.

NOTE: Since some leak test solutions, including soap and water, may be slightly corrosive, all connections should be rinsed with water after checking for leaks.

Additional Leak Check Precautions

The following fittings should be tested for gas leaks each time a connection is made to the gas supply:

- Where the gas hose connects to the gas supply **(B)**.

Follow the instructions for "Checking for Gas Leaks".

Disconnect the Hose from the Gas Supply

- 1) Turn plug anti-clockwise and pull out. This automatically shuts off the gas.

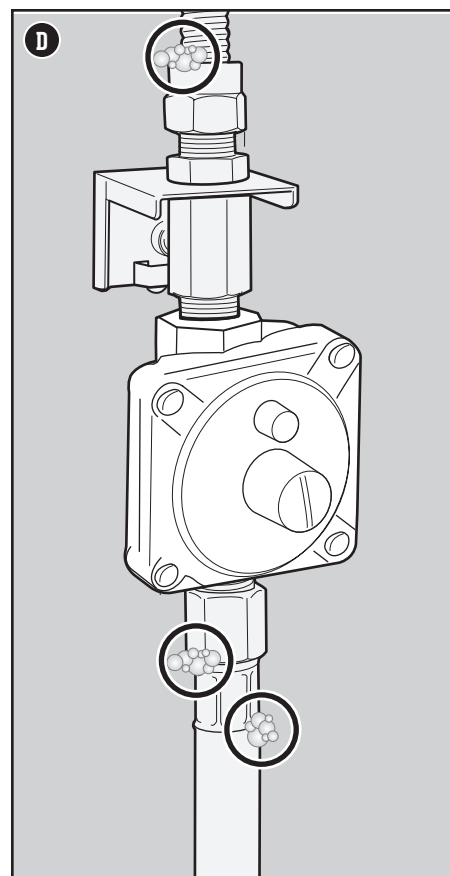
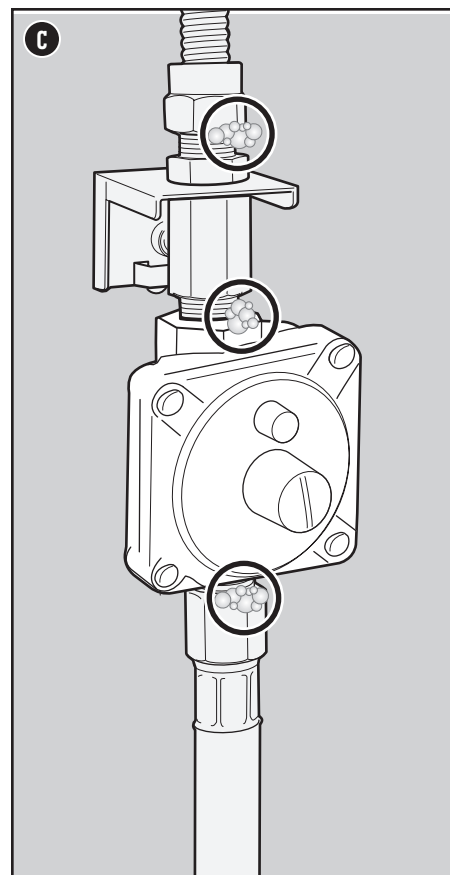
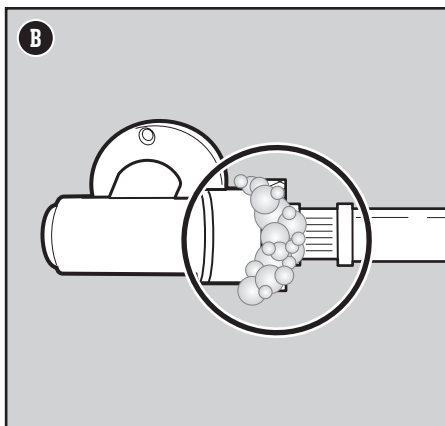
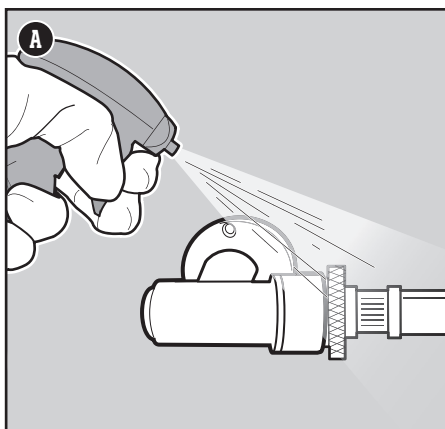

⚠ DANGER: Do not use a flame to check for gas leaks. Be sure there are no sparks or open flames in the area while you check for leaks.

⚠ DANGER: Leaking gas may cause a fire or explosion.

⚠ DANGER: Do not operate the barbecue if there is a gas leak present.

Installing the Safety Tether to Barbecue and Structure

Installation Location

A safety tether is supplied as means of protecting the gas supply fitting. The safety tether bracket must be installed adjacent to and no more than 50 mm (2 inches) from gas supply bayonet fitting.

The barbecue must be positioned at least 61 cm (24 inches) from the gas supply and any combustible surfaces. Avoid excessive tension and force to the gas supply hose fitting when moving the barbecue.

Installing the Mounting Bracket & Tether

- 1) The safety tether mounting bracket must be securely attached to rigid, permanent construction (A). Fasteners used to mount bracket should be suitable for type of construction material. Use concrete anchors for masonry construction.
- 2) Connect the spring hook on the end of the safety tether to mounting bracket (B).
- 3) Pass the safety tether from the back of the barbecue to the inside of the cabinet through the opening in the rear panel (C). Connect the spring hook on the other end of safety tether to the bulkhead bracket (D).

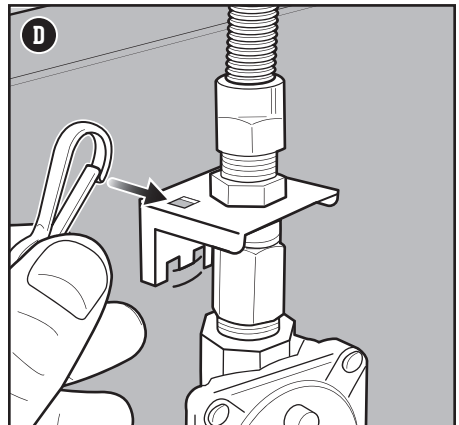
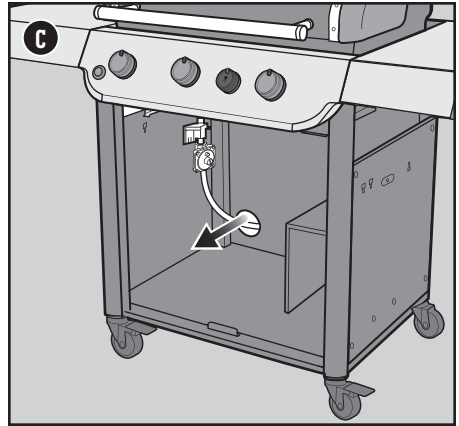
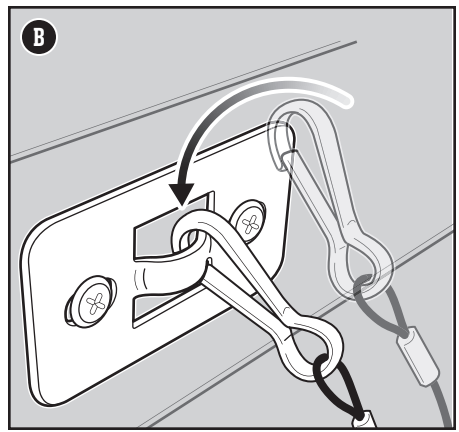
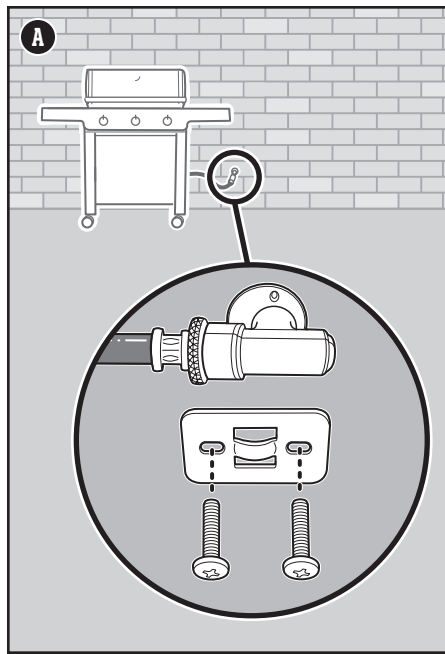

⚠ IMPORTANT: The safety tether must be used and installed correctly before operating the barbecue.

The Very First Time You Barbecue

Perform an Initial Burn-Off

Heat the barbecue on the highest setting, with the lid closed, for at least 20 minutes prior to barbecuing for the first time.

Every Time You Barbecue

Meal-to-Meal Maintenance

The Meal-To-Meal Maintenance plan includes the following simple, yet important, steps that should always be performed prior to barbecuing.

Check for Grease

Your barbecue was built with a grease management system that funnels grease away from food and into a disposable container. As you cook, grease is channelled down the slide-out grease tray and into a disposable drip tray that lines the catch pan. This system should be cleaned each and every time you barbecue to prevent fires.

- 1) Confirm that the barbecue is off and cool.
- 2) Open the doors.
- 3) Access the slide-out grease tray by pulling the tray towards you until it stops (A). Remove excess grease with a plastic scraper. Scrape the grease down through the opening in the grease tray, into the catch pan below.
- 4) Remove the catch pan (B). Check for excessive amounts of grease in the disposable drip pan that lines the catch pan. Discard disposable drip pan when necessary and replace with a new one.
- 5) Reinstall all components.

Inspect the Hose

Routine inspection of the hose is necessary.

- 1) Confirm that the barbecue is off and cool.
- 2) Check hose for any signs of cracking, abrasions, or cuts (C). If the hose is found to be damaged in any way, do not use the barbecue.

Check the Power Cord

Routine inspection of the power cord is necessary.

1. Confirm that the barbecue is off and cool.
2. Check the power cord for any signs of cuts or damage. If the power cord is found to be damaged in any way, do not use the barbecue.
3. Plug the power cord into the port beneath the side table (D) before plugging it into an earthed electrical outlet.
4. Turn on the main power switch (E).

Preheat the Barbecue

Preheating the barbecue is critical to successful barbecuing. Preheating helps to prevent food from sticking to the grills and gets the grills hot enough to sear properly. It also burns off any residue from the previous meal.

- 1) Open the barbecue lid.
- 2) Ignite your barbecue according to the ignition instructions in this Owner's Manual.
- 3) Close lid.
- 4) Preheat the barbecue with all burners on the start/high (F) position for 15 minutes (F).

Clean the Cooking Grills

After preheating, any bits of food or debris left over from previous use will be easier to remove. Cleaned grills will also prevent your next meal from sticking.

- 1) Brush the grills with a stainless steel bristle barbecue brush immediately after preheating (G).

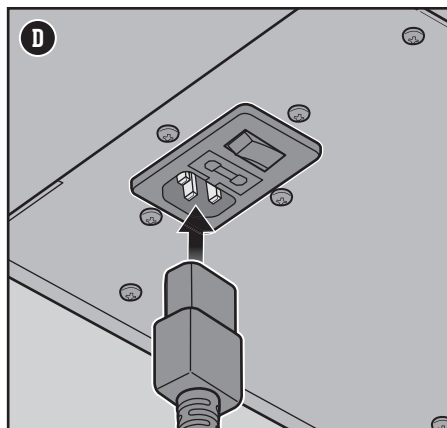
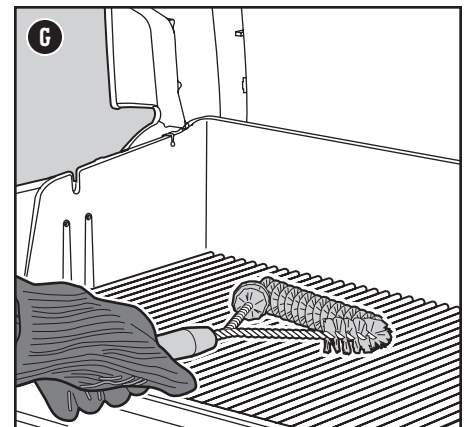
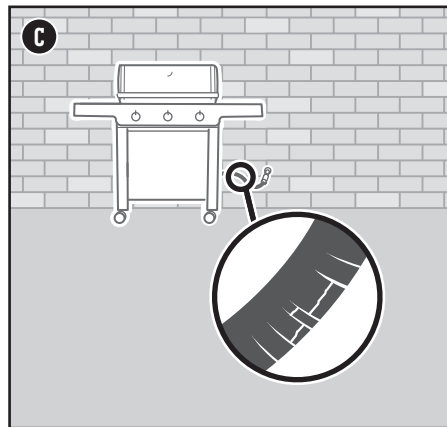
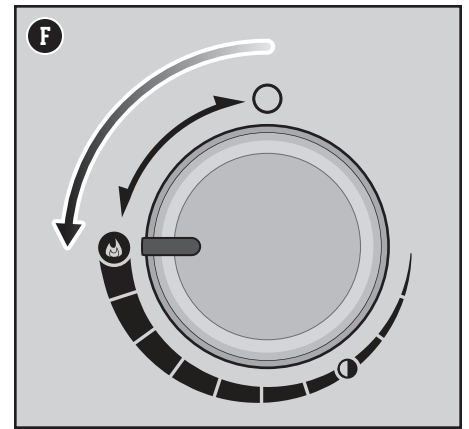
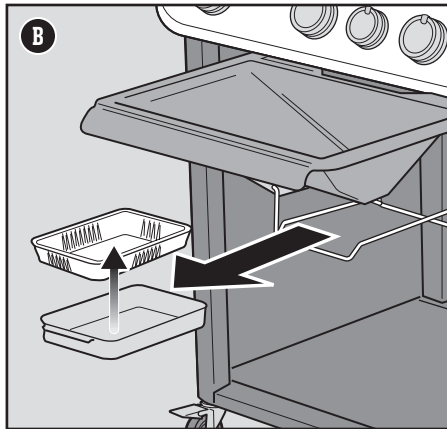
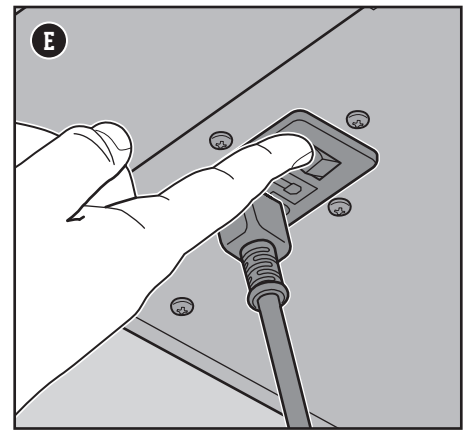
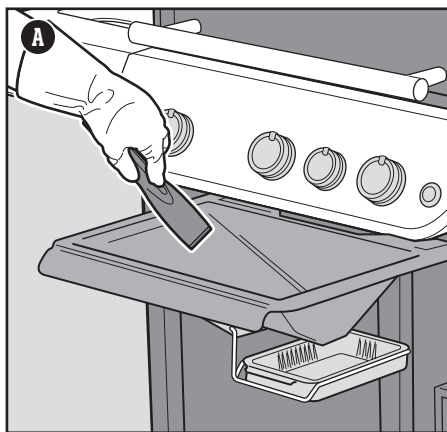

⚠ **DANGER:** Do not line the slide-out grease tray or cookbox with aluminium foil.

⚠ **DANGER:** Check the slide-out grease tray and catch pan for grease build-up before each use. Remove excess grease to avoid a grease fire.

⚠ **WARNING:** Use caution when removing catch pan and disposing of hot grease.

⚠ **WARNING:** Use heat-resistant barbecue mitts or gloves when operating barbecue.

⚠ **WARNING:** Barbecue brushes should be checked for loose bristles and excessive wear on a regular basis. Replace brush if any loose bristles are found on cooking grills or brush. WEBER recommends purchasing a new stainless steel bristle barbecue brush at the beginning of every spring.

⚠ **WARNING:** If the hose is found to be damaged in any way, do not use the barbecue. Replace using only WEBER authorized replacement hose.



⚠ **WARNING:** Keep ventilation openings around tank clear and free of debris.

⚠ **WARNING:** Keep any electrical supply cord and the fuel supply cord away from heated surfaces.

Igniting the Barbecue

Using the Electronic Ignition System to Ignite the Barbecue

Each control knob operates an individual burner, and each burner ignites independently. Ignite the burners starting from left to right. All burners should be lit for preheating, however, all burners do not have to be lit while barbecuing.

- 1) Open the grill lid (A).
- 2) Check that all burner control knobs are in the off  position. Check by pushing in and turning knobs clockwise (B).
- 3) Confirm that gas supply is connected.
- 4) Begin with the burner furthest to the left. Push the burner control knob in and turn it anti-clockwise to the start/high  position (C).
- 5) Push and hold the electronic ignition button (D). You will hear it ticking.
- 6) Check that the burner is lit by looking through the cooking grills and through the half-circle cutout in the FLAVORIZER bar.
- 7) If the burner does not ignite, turn burner control knob to the off  position and wait five minutes to allow the gas to clear before attempting to light the burner again.
- 8) If the burner ignites, repeat steps 4 through 6 to light the remaining burners.

Should the burners fail to ignite using the electronic ignition, refer to the TROUBLESHOOTING section. There you will find instructions on igniting the barbecue with a match to help determine the exact problem.

To Extinguish Burners

- 1) Push each burner control knob in and then turn clockwise all the way to the off  position.

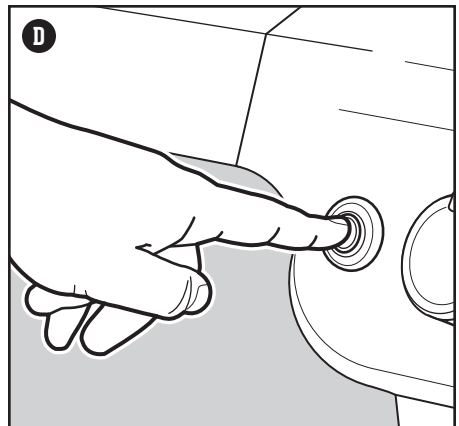
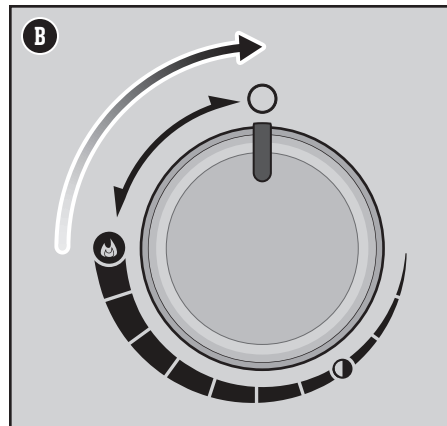
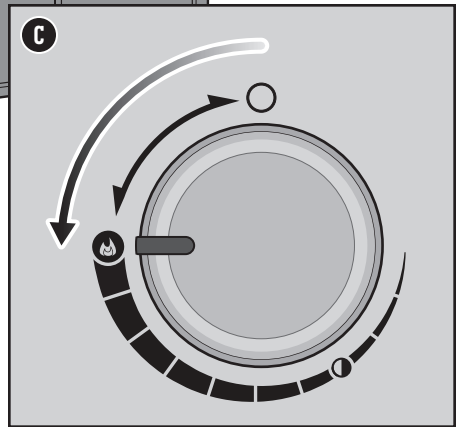
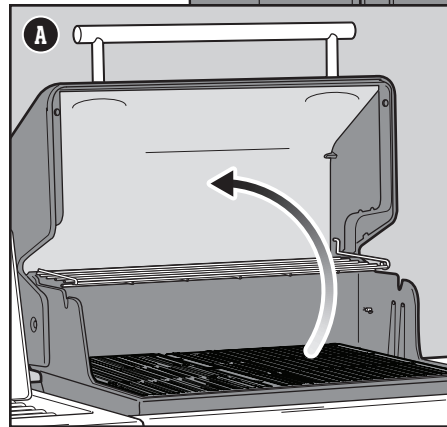
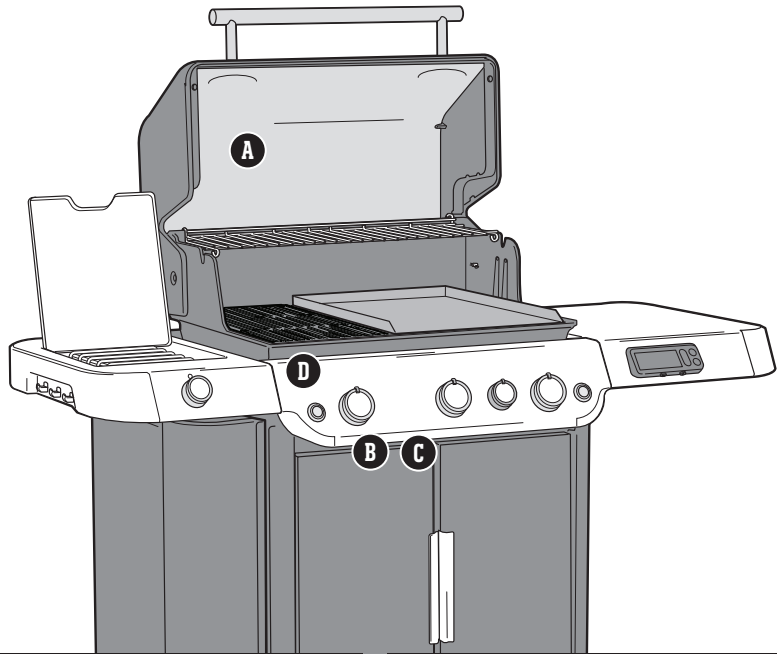

⚠ WARNING: Open lid during ignition.

⚠ WARNING: Do not lean over open barbecue while igniting or cooking.



⚠ WARNING: Each burner must be ignited individually by pushing the electronic ignition button.

⚠ WARNING: If ignition does not occur within four seconds of attempting to light the first burner, turn the burner control knob to the off position. Wait five minutes to allow accumulated gas to dissipate, and then repeat the lighting procedure.

Using the Sear Zone

Searing is a direct barbecuing technique used on meats, such as steak, poultry parts, fish and chops. Searing browns the surface of the food at a high temperature. By searing both sides of the meat, you caramelize the food surface, creating a more desirable flavour.

Ignition of the sear burner is the same as ignition of a main burner, each burner ignites independently.

- 1) Open the lid and ignite all of the burners including the sear burner. Refer to USING THE ELECTRONIC IGNITION SYSTEM TO IGNITE THE BARBECUE.
- 2) Preheat the barbecue with the lid closed and with all burners on the start/high  position for 15 minutes.
- 3) After preheating, leave the sear burner control knob and the adjacent burner control knobs in the start/high  position (A). The sear burner works in tandem with adjacent burners (B). The remaining burner(s) can be turned to off or low.
- 4) Place meat directly over the sear zone and close lid. Sear each side anywhere from one to four minutes (C), depending on the type and thickness of meat. Once searing is complete, the meat can be moved over to moderate heat and cooked to your desired doneness.

Note: Always cook with the lid closed to achieve maximum heat and to avoid flare-ups.

As you gain experience using the sear zone we encourage you to experiment with different searing times to find the results that work best for your taste.

To Extinguish Burners

- 1) Push each burner control knob in and then turn clockwise all the way to the off  position.
- 2) Turn gas supply off.

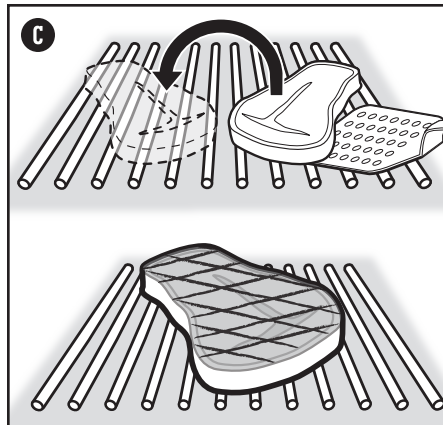
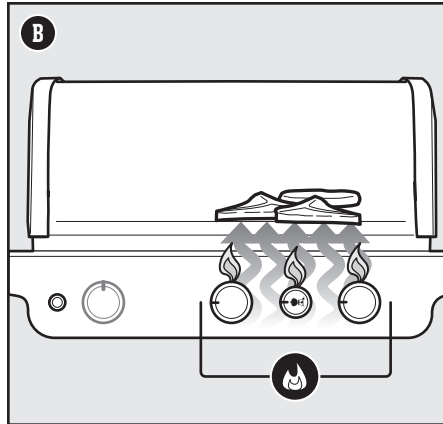
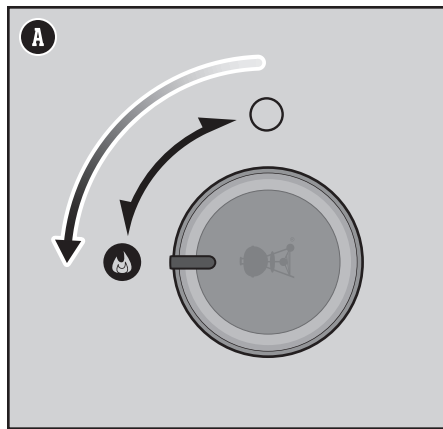

Igniting the Side Burner

Use the Electronic Ignition to Ignite the Side Burner

If one or more of the main burners on your barbecue are already lit and you would like to ignite the side burner, skip to step 3. If none of the main burners are lit and you are only using the side burner, start with step 1.

- 1) Check that the side burner control knob is in the off \circ position. Check by pushing in and turning the knob clockwise (A). Also check that all main burner control knobs are in the off \circ position.
- 2) Confirm that gas supply is connected.
- 3) Open the side burner lid (B).
- 4) Push in and turn the side burner control knob anti-clockwise to start/high \bullet position (C).
- 5) Push and hold in the electronic ignition button (D). You will hear the igniter clicking. Check that the side burner is lit. The side burner flame may be difficult to see on a bright sunny day.
- 6) Once side burner is ignited, continue turning the knob anti-clockwise until you reach the desired position.
- 7) If the side burner does not ignite within 4 seconds, turn side burner control knob to the off \circ position and wait five minutes to allow the gas to clear before attempting to light the burner again.

Should the side burner fail to ignite using the electronic ignition, refer to the TROUBLESHOOTING section. There you will find instructions on igniting the side burner with a match to help determine the exact problem.

To Extinguish Side Burner

- 1) Push side burner control knob in and then turn clockwise all the way to the off \circ position.

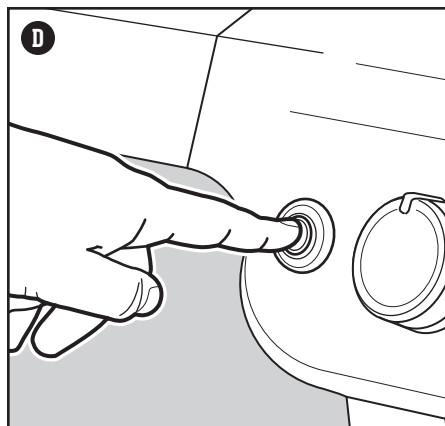
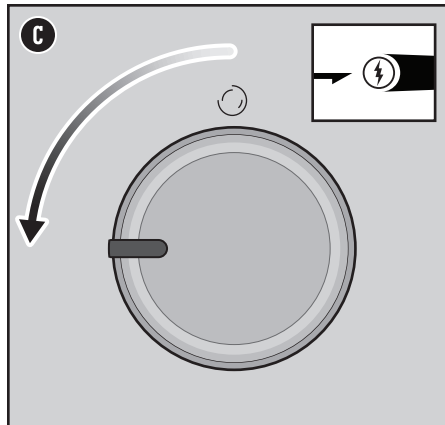
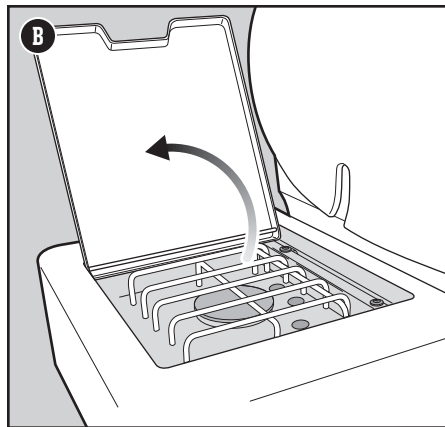
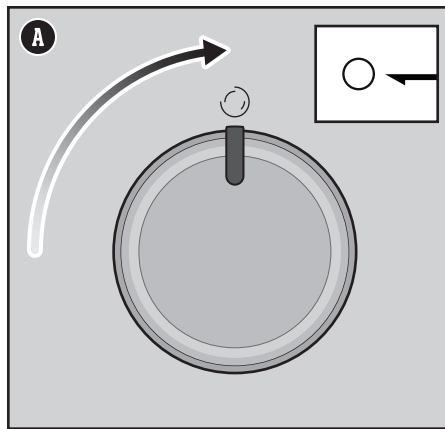

⚠ **WARNING:** Open side burner lid during ignition.

⚠ **WARNING:** Do not lean over side burner while igniting or cooking.

⚠ **WARNING:** If ignition does not occur within four seconds of attempting to light the side burner, turn the burner control knob to the off position. Wait five minutes to allow accumulated gas to dissipate, and then repeat the lighting procedure.

Integrated WEBER CONNECT Technology



WEBER CONNECT App

First things first.

Download the WEBER CONNECT app.

Open the app to receive:

- Flip and Serve Notifications
- Food Readiness Countdowns
- Custom Food Doneness Alerts
- Step-By-Step Barbecuing Assistance

Connecting Your Barbecue to Bluetooth® or a Wi-Fi Network

To connect your WEBER barbecue via Bluetooth® or your local Wi-Fi network, follow these steps:

NOTE: WEBER recommends that your smart device runs the latest version of its operating system before attempting to connect your barbecue to Bluetooth® or your Wi-Fi network.

- 1) Push any button located on the temperature controller to turn ON the WEBER CONNECT module.
- 2) Verify that your smart device is connected to Bluetooth® or your local Wi-Fi network.
- 3) From your smart device, download the new WEBER CONNECT app from the App Store on Apple devices, or the Play Store on Android devices.
- 4) Open the WEBER CONNECT app and follow the in-app instructions for connecting to your WEBER barbecue.

NOTE: In order to successfully connect your smart device to your barbecue via a local Wi-Fi network, first make sure your barbecue is paired via Bluetooth® and that your barbecue is within range of your Wi-Fi router. If your attempts to connect have been unsuccessful, try moving the barbecue within range of the Wi-Fi router or adding a signal extender for a stronger signal.

Using the WEBER CONNECT Module

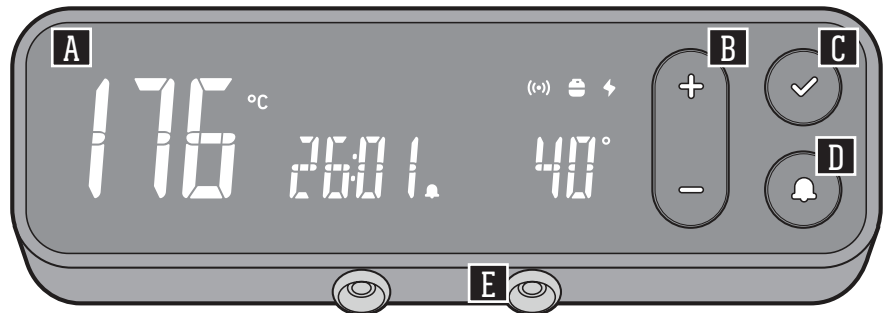

Model: WC2 CONTROLLER

A Dashboard

The LED display dashboard on your module is where you can visually check temperatures, receive notifications, view connectivity status, and check the status of your cooking session.



Push the **+** or **-** buttons to increase or decrease target temperatures. Push the **✓** button to confirm your selection.

C ✓ Confirm Selection / Turn Display Off

After selecting a target temperature, push the **✓** button to confirm the selection. Hold the same button for three seconds to turn off the display.

D 🛎 Target Temperature Alert

Push the **🛎** button to set an alert for the barbecue and/or meat probe temperatures. Push the **+** or **-** buttons to increase or decrease the desired target temperature. Push the **✓** button to confirm the target temperature alert. To clear the alert, select the desired input and press/hold the **-** button until dash marks appear.

E Food Temperature Probes

Your new WEBER CONNECT module can handle up to two separate food temperature probes (one probe included) to gain superior control of your barbecue for perfect results every time.

NOTE: Download the WEBER CONNECT app to get the latest barbecue software and features.

Notifications	
	Power Indication
	A green wireless symbol is shown on the WEBER CONNECT module display when connected to the WEBER CONNECT app via your local Wi-Fi network. A blue wireless symbol is shown on the WEBER CONNECT module display when connected to the WEBER CONNECT app via Bluetooth®.
	A bell alert icon will display when a target temperature is set.

Setting a Barbecue Temperature Notification

Please follow these steps for setting a notification to alert you when your barbecue has reached a target internal temperature:

- 1) Push any button located on the temperature controller to turn ON the WEBER CONNECT module.
- 2) Push the BELL button to activate barbecue temperature notification.
- 3) While the display is blinking, push the + or - buttons to set the target barbecue temperature. Push the CHECKMARK button to confirm your selection.
- 4) Repeat steps 2 and 3 to update or set a new target temperature.
- 5) Once the barbecue reaches the target temperature, the BELL button will blink, the controller will ding, and if using the WEBER CONNECT app, you will receive a push notification on your smart device.
- 6) All of these WEBER CONNECT module functions can also be set wirelessly via Wi-fi or Bluetooth® from the WEBER CONNECT app on your smart device.

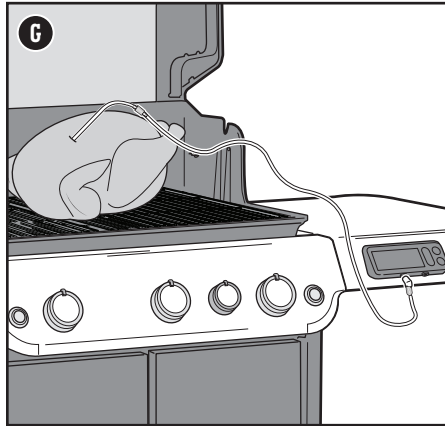
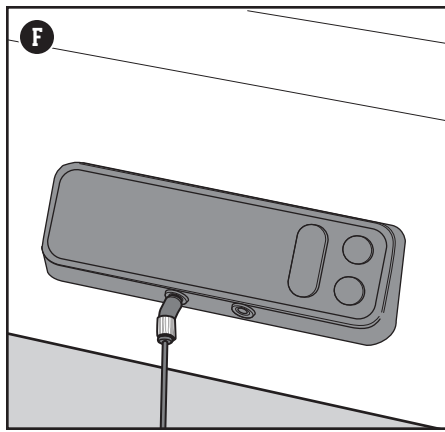

Barbecuing with Food Temperature Probes

Use the included food temperature probe to monitor your WEBER barbecue for the perfect food, every time. Please follow these steps for using food temperature probes:

- 1) Once the barbecue has been preheated, open the barbecue lid and clean the cooking grills using a barbecue brush or scraper, then set the control knobs to the desired barbecue temperature.
- 2) Place your food on the grills.
- 3) Plug the food temperature probe(s) into the ports of the WEBER CONNECT module (F) and, using heat-resistant barbecue mitts or gloves, route the food temperature probe cables through the side channel on the barbecue(G).
- 4) Insert food probe(s) into the centre of the thickest part of your food.
- 5) Close the barbecue lid.
- 6) Push any button located on the temperature controller to turn ON the WEBER CONNECT module.
- 7) Push the BELL button to navigate between barbecue temperature and food temperature probes 1 and 2.
- 8) Once you select which probe you are using, push the + or - buttons to set the target food temperature. Push the CHECKMARK button to confirm your selection.
- 9) Repeat steps 7 and 8 to update or set a new target temperature.
- 10) Once the probe reaches the target temperature, the BELL button will blink, the controller will ding, and if using the WEBER CONNECT app, you will receive a push notification on your smart device.
- 11) All of these WEBER CONNECT module functions can also be set wirelessly via Wi-fi or Bluetooth® from the WEBER CONNECT app on your smart device.

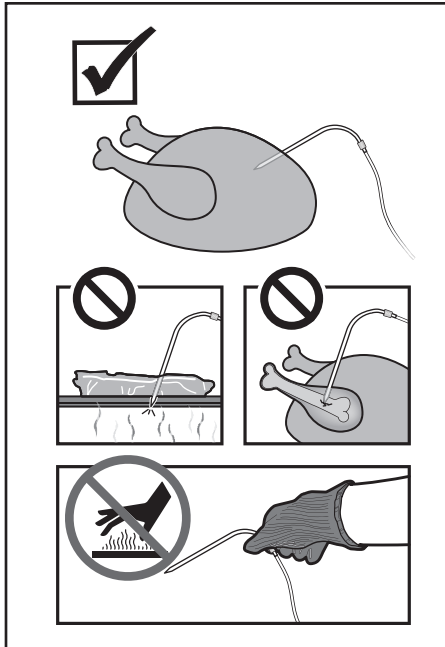

Food Temperature Probe Care

Cleaning the Food Temperature Probe

Clean the probe before first use. The probe should be cleaned by wiping with water and a damp cloth. The food temperature probes are not dishwasher safe or waterproof and damage may result from excessive water exposure. Never submerge the probes directly in water or other liquids.

Storing Food Temperature Probe

Once cleaned, neatly wrap the probe when not in use and store indoors.

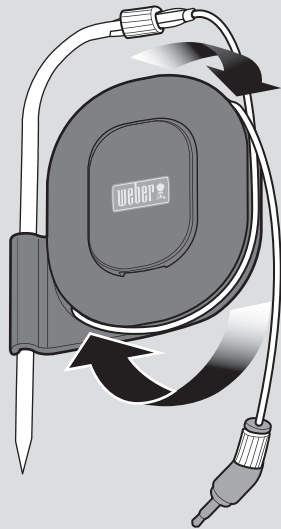
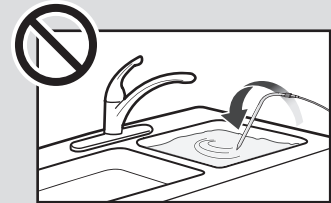
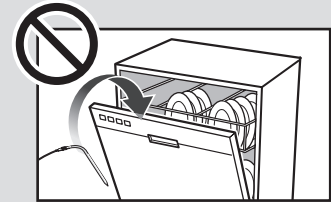

⚠ WARNING

⚠ Risk of injury! The food temperature probes are very sharp. Please be careful when handling probes.

⚠ Risk of burns! Handling the food temperature probes without hand protection will result in severe burns. The coloured probe indicators are not intended to be touched with bare hands while using the barbecue as they are not heat-insulated. Please wear heat-resistant gloves at all times while using this product in order to avoid being burned.

The Flame - Direct or Indirect

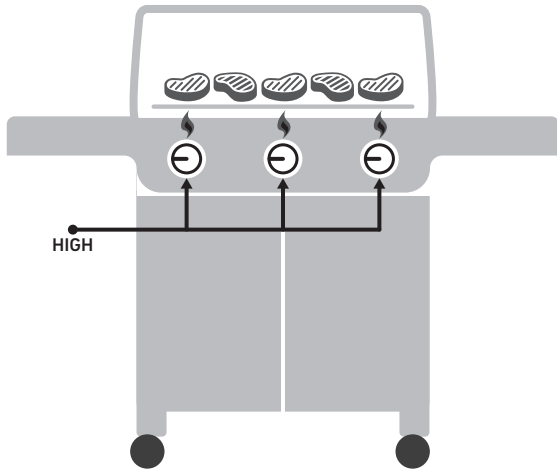

DIRECT HEAT SETUP

Use the direct method for small, tender pieces of food that take less than 20 minutes to cook, such as: hamburgers, steaks, chops, kebabs, boneless chicken pieces, fish fillets, shellfish and sliced vegetables.

With direct heat, the fire is right below the food. It sears the surfaces of the food, developing flavors, texture, and delicious caramelisation while cooking the food all the way to the centre.

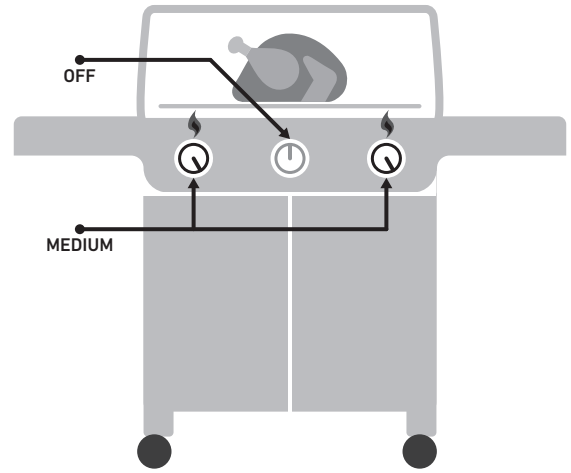

INDIRECT HEAT SETUP

Use the indirect method for larger cuts of meat that require 20 minutes or more of barbecuing time, or for foods so delicate that direct exposure to heat would dry them out or scorch them, such as: roasts, bone-in poultry pieces, whole fish, delicate fish fillets, whole chickens, turkeys, and ribs. Indirect heat can also be used for finishing thicker foods or bone-in cuts that have been seared or browned first over direct heat.

With indirect heat, the heat is on both sides of the barbecue, or off to one side of the barbecue. The food sits over the unlit part on the cooking grate.

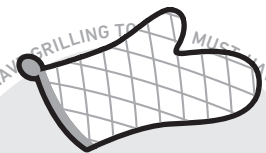
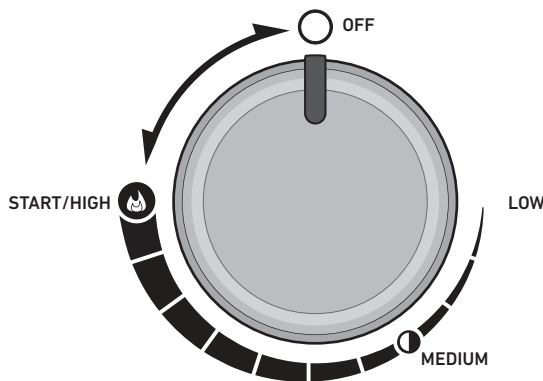

BARBECUE MITTS

When in doubt, wear them. The good ones are insulated and protect both hand and forearm.

MUST-HAVE GRILLING TOOLS • MUST-HAVE GRILLING TOOLS • MUST-HAVE GRILLING TOOLS • MUST-HAVE GRILLING TOOLS • MUST-HAVE GRILLING TOOLS • MUST-HAVE GRILLING TOOLS • MUST-HAVE GRILLING TOOLS • MUST-HAVE GRILLING TOOLS • MUST-HAVE GRILLING TOOLS • MUST-HAVE GRILLING TOOLS

Discover What's Possible

WEBER CRAFTED Outdoor Kitchen Collection Ready

This feature is only available on selected models.

Some models are Outdoor Kitchen Collection Ready with the included Grills and Frame. Remove the right-hand cooking grill. Place the Frame on the right-hand side of the cooking box for the widest range of heat control **(A)**.

The Spacer included with your barbecue is only to be used when cooking with the WEBER CRAFTED Outdoor Kitchen Collection **(B)**.

Look for these and other accessories on weber.com.

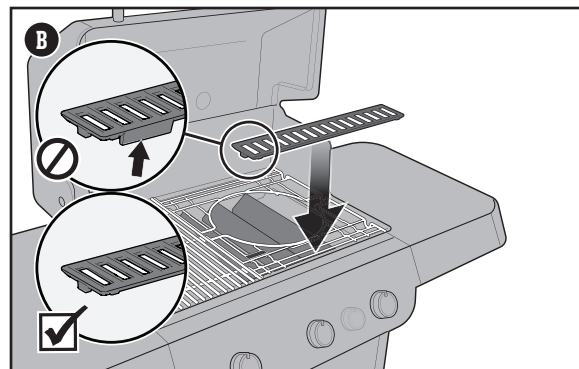
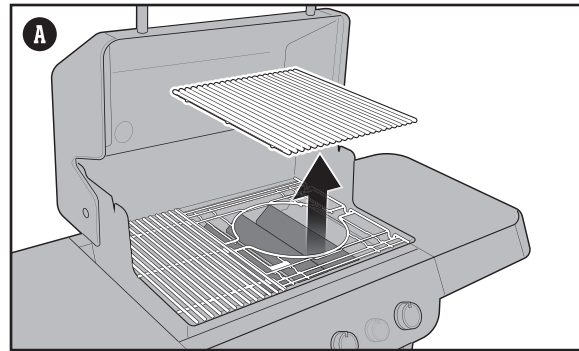

Barbecuing Do's and Don'ts

Preheat each and every time.

If the cooking grills are not hot enough, the food will stick and you will likely never have a chance of searing your food properly or developing those handsome sear marks. Even if a recipe calls for medium or low heat, always preheat the barbecue on the highest setting first. Open the lid, turn up the heat, close the lid, and then let the cooking grill heat up for 15 minutes on high.

Don't barbecue on dirty grills.

Placing food onto the cooking grills before they have been cleaned is never a good idea. Leftover "stuff" on the grills acts like glue, binding it to the grills and your new food. To avoid tasting last night's dinner on today's lunch, make sure that you are barbecuing on a clean cooking grill. Once the grills are preheated, use a stainless steel bristle barbecue brush to make a clean, smooth surface.

Be present in the process.

Before firing up your barbecue, make sure that everything you need is within arm's reach. Don't forget your essential barbecuing tools, such as oiled and seasoned food, glazes or sauces and clean cooking platters for the cooked food. Having to run back to your kitchen not only means missing out on the fun, but it could also result in burning your food. French chefs call this 'mise en place' (meaning, 'put in place'). We call it 'being present'.

Create a little elbow room.

Packing too much food onto the cooking grills restricts your flexibility. Leave at least one-quarter of the cooking grills clear with plenty of space between each food item in order to get your tongs in there and easily move the food around. Sometimes barbecuing involves split-second decisions and the need to move food from one area of the barbecue to another. So give yourself enough room to operate.

Try not to peek.

The lid on your barbecue is for more than just keeping the rain out. Most importantly, it's for preventing too much air from getting in and too much heat and smoke from getting out. When the lid is closed, the cooking grills are hotter, the barbecuing times are faster, the smoky tastes are stronger, and the flare-ups are fewer. So put a lid on your barbecue!

Only flip once.

What's better than a juicy steak with a deep sear and plenty of beautifully-caramelised bits? The key to accomplishing these results is to keep your food in place. Sometimes we have the tendency to flip our food before it reaches the desired level of colour and flavour. In nearly all cases, you should turn food just once. If you are moving it more than that, you are probably also opening the lid too often which causes its own set of problems. So step back and trust the barbecue.

Know when to tame the flame.

When barbecuing, sometimes the most important thing to know is when to stop. The most reliable way to test doneness of your food is to invest in an instant-read thermometer. This slim little gem will help you pinpoint that critical moment when your food is at its best.

Don't be afraid to experiment.

Back in the 1950s, barbecuing meant one thing: meat (and only meat) charred over open flames. The modern day garden chef doesn't need a kitchen in order to prepare a full course meal. Use your barbecue to make char-grilled starters, sides, and even sweets. Register your barbecue to receive special content that will inspire you along the way. We'd love to join you on your barbecuing adventures.

Real Smoke Flavour

Using the Smoker Box

This feature is only available on selected models.

Use dry wood chips in the smoker box as they ignite quickly and create smoke faster. For longer cooking foods such as roasts, chicken, and turkeys, etc., fill the entire length of the smoker box with wood chips. The wood chips will ignite on the end of the smoker box which is positioned over the burner and slowly continue to burn inside the smoker box to provide smoke throughout the cooking session. As you gain experience in using your smoker, we encourage you to experiment with different combinations of wood chips to find the smoke flavour that best suits your taste.

Option 1: Setting up for Indirect Cooking

- 1) Open the barbecue lid.
- 2) Check that all burner control knobs are in the off \circ position and the barbecue is cool. Check by pushing in and turning knobs clockwise.
- 3) Remove the cooking grills to expose the FLAVORIZER BARS (A).
- 4) Open the lid of the smoker box.
- 5) Fill the smoker box with wood chips from end to end (B). Close the smoker box lid.
- 6) With the barbecue off, position the smoker box over the two right-hand side FLAVORIZER BARS, near the front of the barbecue, making sure only the narrow end with the WEBER logo will be directly over a lit burner (C). This is the end where the wood chips ignite first. The main body of the smoker box aligns on a FLAVORIZER BAR without a lit burner beneath it.
- 7) Add water to the water pan of the smoker box (D) for more flavourful smoke during the cooking session.
- 8) Reinstall the cooking grills over the smoker box (E).
- 9) Ignite the barbecue and preheat for 10 minutes with only the main burners on high. Refer to "Igniting the Barbecue". After preheating, turn off the centre burner and reduce outer burners to low (F).

Smoke will start in approximately 10 minutes and last for as long as 90 minutes. Do not attempt to move hot components to refill the smoker with wood chips. Keep the lid of the barbecue closed while cooking.

Option 2: Setting up for Direct Cooking

The smoker box is positioned where the Weber logo is over the centre burner during barbecuing, with main burners set on low (G).

Notes

For best smoking results, burners in use should be on low. Do not place the main body of the smoker box directly over a burner. This could ignite all of the wood chips at once resulting in reduced smoking times.

Always barbecue with the lid closed to allow the smoke to fully penetrate the food.

When you're finished smoking, turn burners off and close the barbecue lid until the wood chips have extinguished.

Remove smoker box from the barbecue if not in use.

Cleaning the Smoker Box

Before each use, empty the smoker of ash to allow proper air flow.

Note: Smoking will leave a "smoke" residue on the surface of the smoker. This residue cannot be removed and will not affect the function of the smoker. To a lesser degree, a "smoke" residue will accumulate on the inside of your gas barbecue. This residue need not be removed and will not adversely affect the function of your gas barbecue.

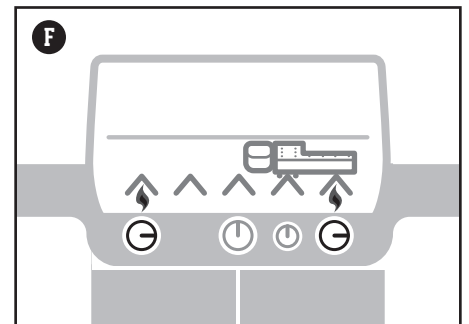
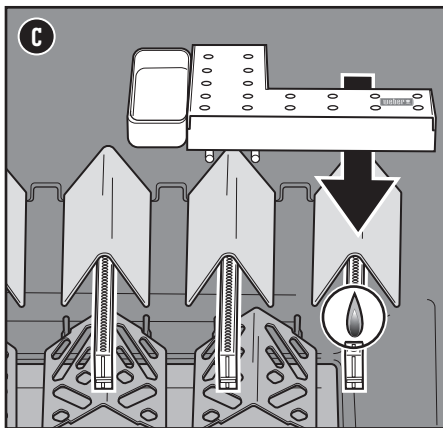
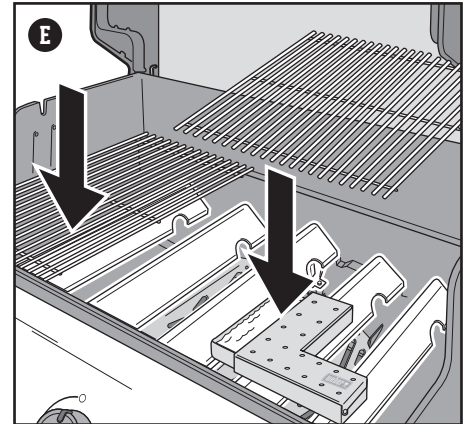
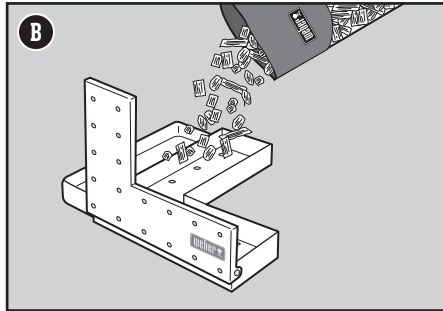
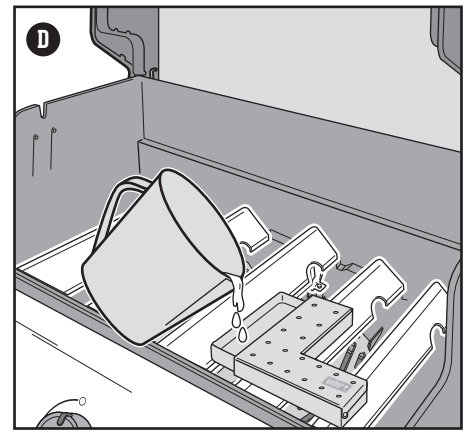
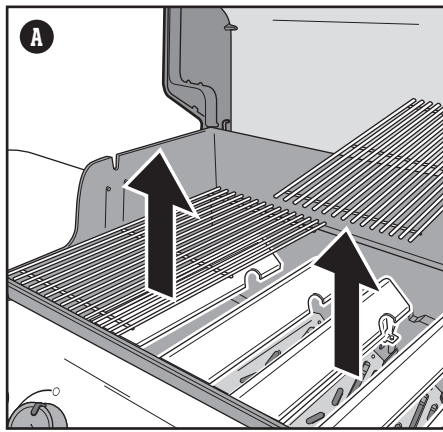

⚠ DANGER: Do not use any flammable fluid or combustible products in the smoker to ignite the wood chips. This will cause serious bodily injury.

⚠ WARNING: Do not remove hot components from the barbecue while in use.

⚠ WARNING: Never use wood that has been treated or exposed to chemicals.

⚠ Always avoid soft, resinous woods like pine, cedar and aspen.

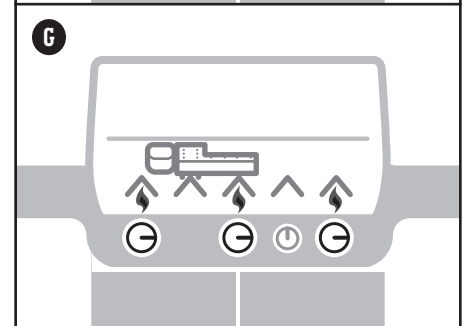

	APPLE FIRESPICE	CHERRY FIRESPICE	PECAN FIRESPICE	HICKORY FIRESPICE	MESQUITE FIRESPICE
	✓	✓	✓		
	✓	✓	✓	✓	
	✓	✓	✓	✓	✓
			✓		✓
			✓	✓	✓
	✓	✓			

Extra on the Side

WEBER CRAFTED Grill Locker

This feature is only available on selected models.

The side storage area (A) is ideal for storing accessories and grillware.

The adjustable condiment basket keeps smaller items close at hand.

Always make sure the rubber mat is in place to protect surfaces.

Storage Hooks

Use the double-sided hooks on the side of the cabinet (B) for convenient storage of cooking grills on the outside of the barbecue. Additional hooks on the inside of the cabinet store the WEBER CRAFTED spacer grill, which can be used with WEBER CRAFTED Outdoor Kitchen Collection grillware..

Note: Do not place hot cooking grills on storage hooks.

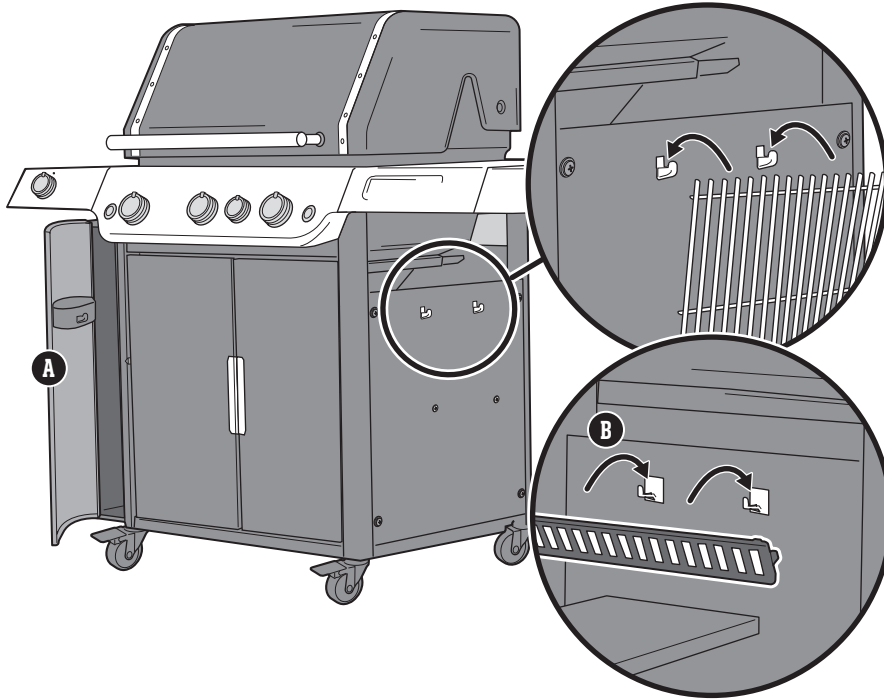

More Cooking Space

Using the Expandable Top Cooking Grill

Use it as a warming rack to keep food warm (A) or unfold it when you need a secondary cooking surface. To unfold, lift the front half of the grill slightly and rotate outward (B). For storage, fold the grill and lift the entire grill from the cooking box (C). Hang the grill vertically on the back edge of the cook box. Use heat-resistant mitts or gloves when adjusting rack.

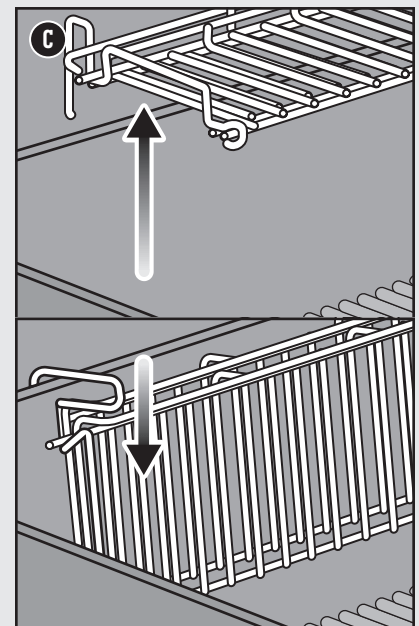
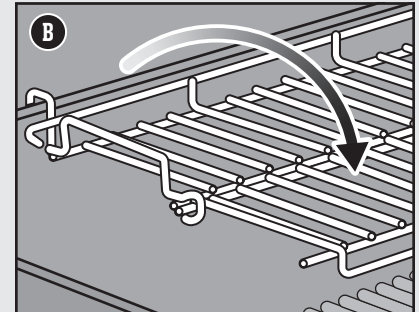
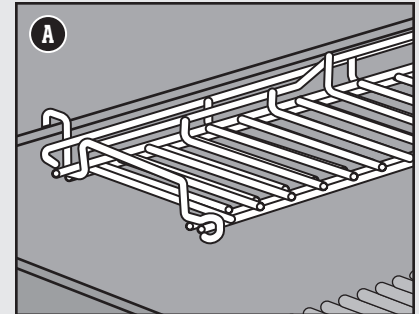

Barbecuing at Night

This feature is only available on selected models.

Using the Barbecue Lighting

To activate the barbecue light press the awake button. The barbecue light has a tilt sensor that will turn on the light if the barbecue lid is opened and turn off the light when the barbecue lid is closed. If the lid is left open or closed for more than 30 minutes, the barbecue light will be deactivated automatically. To turn the light back on, press the AWAKE button.

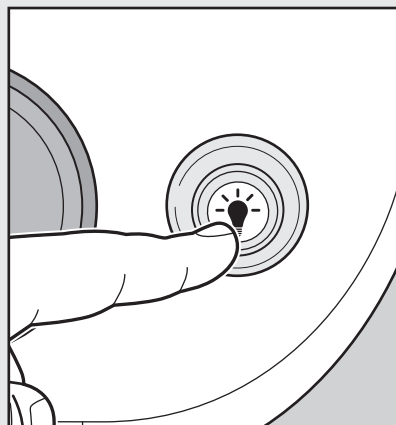
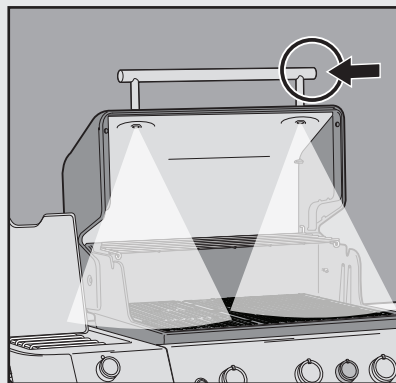

Using the Lighted Control Knobs

The burner control knobs light up with the push of a button. To turn on or off, simply push the power button located on the right side of the control panel.

Cleaning and Maintenance

Cleaning the Inside of the Barbecue

Over time, the performance of your barbecue can diminish if it has not been maintained properly. Low temperatures, uneven heat, and food sticking to cooking grills are all signs that cleaning and maintenance are overdue. When your barbecue is off and cool, start by cleaning the inside from the top down. A thorough cleaning is recommended at least twice a year. Consistent use may require quarterly cleanings.

Cleaning the Lid

From time to time you may notice 'paint-like' flakes on the inside of the lid. During use, grease and smoke vapours slowly change into carbon and deposit on the inside of your barbecue's lid. These deposits will eventually peel, and look very similar to paint. These deposits are non-toxic, but the flakes could fall onto your food if you do not clean the lid regularly.

- 1) Brush the carbonised grease from the inside of the lid with a stainless steel bristle barbecue brush (A). To minimise further build-up, the inside of the lid can be wiped with a paper towel after barbecuing while the barbecue is still warm (not hot).

Cleaning the Cooking Grills

If you have been cleaning your cooking grills as recommended, the debris on your grills should be minimal.

- 1) With grills installed, brush the debris off your cooking grill with a stainless steel bristle barbecue brush (B).
- 2) Take the grills out and set aside.

Cleaning the FLAVORIZER BARS

FLAVORIZER BARS catch drippings that smoke and sizzle, adding flavour to your food. Any drippings that are not vapourised by the FLAVORIZER BARS are funnelled away from the burners. This helps prevent flare-ups inside of your barbecue, and protects the burners from getting clogged.

- 1) Scrape the FLAVORIZER BARS with a plastic scraper (C).
- 2) If necessary, brush the FLAVORIZER BARS with a stainless steel bristle barbecue brush.
- 3) Remove FLAVORIZER BARS and set aside.

Cleaning the Burners

Two areas on the burners that are key to optimum performance are the ports (small raised openings running along the length of the burners) and the spider/insect screens on the ends of the burner. Keeping these areas clean is essential for safe operation.

Cleaning the Burner Ports

- 1) Use a clean stainless steel bristle barbecue brush to clean the outside of the burners by brushing across the top of the burner ports (D).
- 2) When cleaning the burners, avoid damaging the ignition electrode by carefully brushing around it (E).

Cleaning the Spider Screens

- 1) Locate the ends of the burners on the underside of the control panel where they meet the valves.
- 2) Clean the spider/insect screens on each of the burners using a soft bristle brush (F).

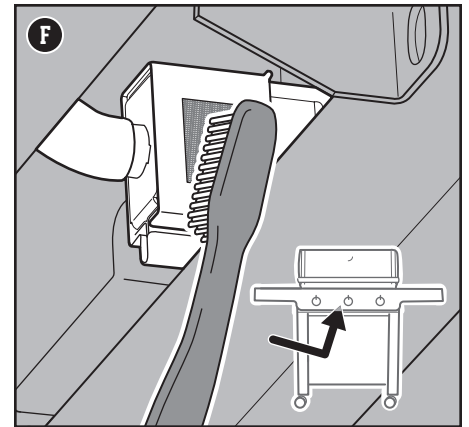
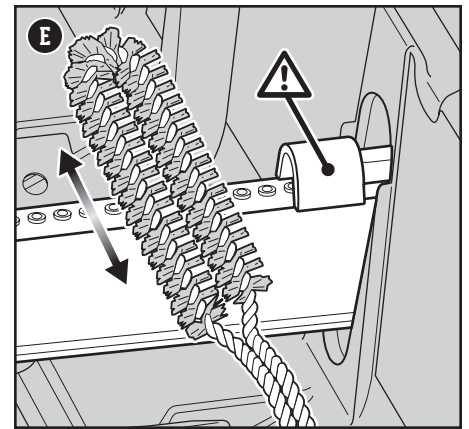
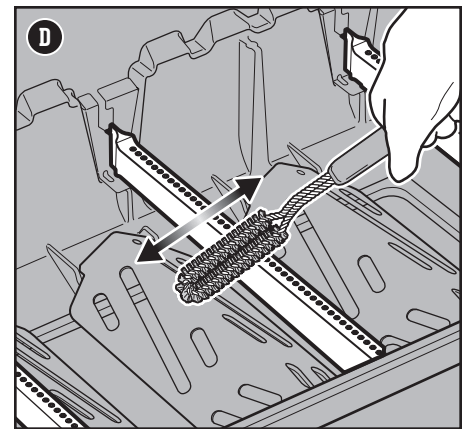
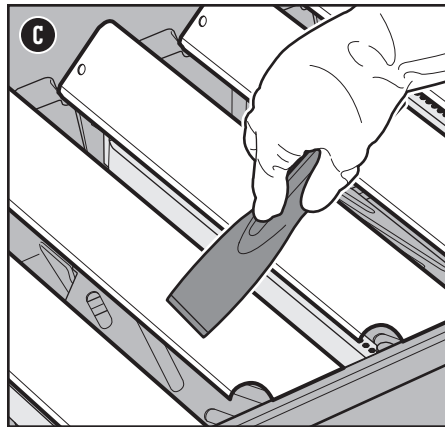
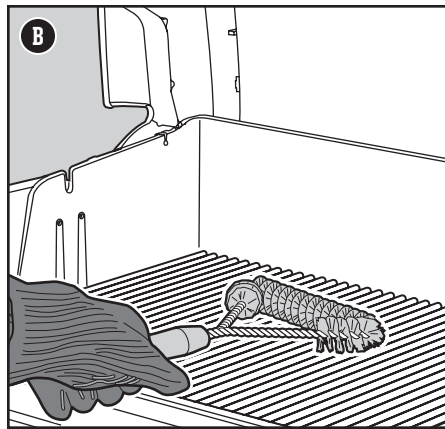
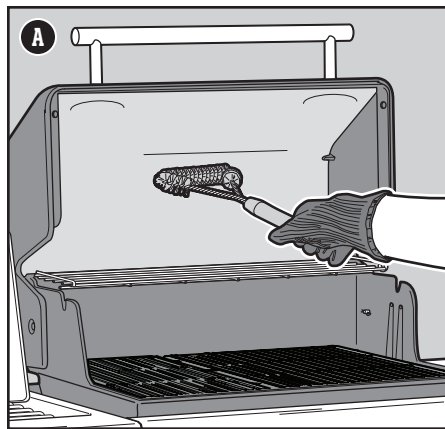

⚠ **WARNING:** Turn your barbecue off and wait for it to cool before thoroughly cleaning it.

⚠ **WARNING:** Over time, the development of rough surfaces can form on the FLAVORIZER BARS. Wearing gloves is recommended when handling. Do not clean FLAVORIZER BARS or cooking grates in a sink, dishwasher, or self-cleaning oven.

⚠ **WARNING:** When cleaning the burners, never use a brush that has already been used to clean the cooking grates. Never put sharp objects into the burner port holes.

⚠ **CAUTION:** Do not place any barbecue components onto the side tables as they may scratch the paint or stainless steel surfaces.

⚠ **CAUTION:** Do not use any of the following to clean your barbecue: abrasive stainless steel polishes or paints, cleaners that contain acid, mineral spirits or xylene, oven cleaner, abrasive cleaners (kitchen cleaners) or abrasive cleaning pads.

Cleaning the Heat Deflectors

Located under the burners, the heat deflectors distribute heat evenly throughout the cookbox while cooking. Keeping heat deflectors clean will enhance the cooking performance of your barbecue.

- 1) Scrape the heat deflectors with a plastic scraper (G).
- 2) If necessary, brush the heat deflectors with a stainless steel bristle barbecue brush.
- 3) Remove heat deflectors and set aside.

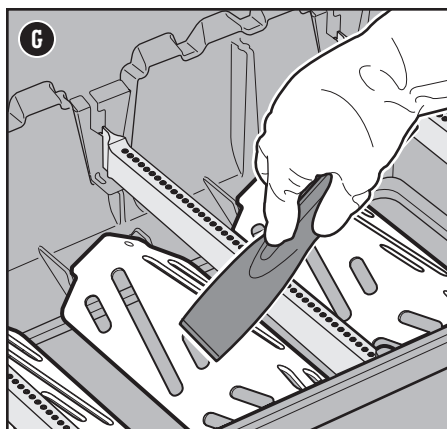

Cleaning the Cookbox

Look inside the cookbox for any grease accumulation or leftover food particles. Excessive accumulation can cause a fire.

- 1) Use a plastic scraper to scrape debris off the sides and bottom of the barbecue into the opening in bottom of the cooking box (H). This opening leads debris into the slide-out grease tray.

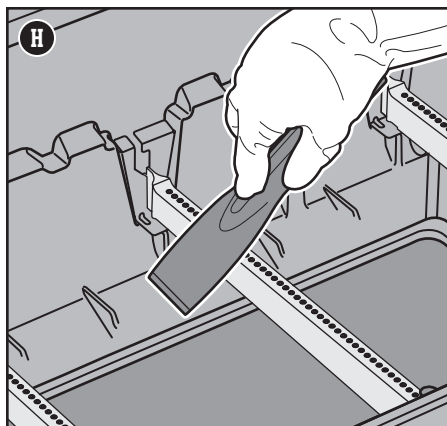

Cleaning the Grease Management System

The grease management system consists of an angled slide-out grease tray and a catch pan. These components were designed to be easily removed, cleaned, and replaced; an essential step every time you prepare to barbecue. Instructions on inspecting the grease management system can be found in MEAL-TO-MEAL MAINTENANCE.

Cleaning the Outside of the Barbecue

The outside of your barbecue may include stainless steel, porcelain-enamelled, and plastic surfaces. WEBER recommends the following methods based on the surface type.

Cleaning Stainless Steel Surfaces

Clean stainless steel using a non-toxic, non-abrasive stainless steel cleaner or polish designed for use on outdoor products and barbecues. Use a microfibre cloth to clean in the direction of the grain of the stainless steel. Do not use paper towels.

Note: Do not risk scratching your stainless steel with abrasive pastes. Pastes do not clean or polish. They will change the colour of the metal by removing the top chromium oxide film coating.

Cleaning Painted, Porcelain-Enamelled Surfaces and Plastic Components

Clean painted, porcelain-enamelled and plastic components with warm soapy water, and paper towels or cloth. After wiping down the surfaces, rinse and dry thoroughly.

Cleaning the Outside of Barbecues that are in Unique Environments

If your barbecue is subject to a particularly harsh environment, you will want to clean the outside more often. Acid rain, pool chemicals, and salt water can cause surface rusting to appear. Wipe down the outside of your barbecue with warm soapy water. Follow up with a rinse and thorough drying. Additionally, you may want to apply a stainless steel cleaner weekly to prevent surface rust.

Cleaning the Lenses of the Barbecue Lighting

Apply a mild grease cleaner to each lens using a soft cloth. Weber recommends "Weber Stubborn Stain" Cleaner for safe, effective results. Allow cleaner to stay on lens for up to five minutes. Scrub grease and cleaner away with a paper towel.

Cleaning is recommended every eight cooks or once a month.

Cleaning Around the Electronic Components

Use a soft, damp cloth to wipe the interior of the cabinet and around the side tables. Be careful not to pull any of the wire connections when cleaning around the electronic components.

CAUTION: NEVER SPRAY THE BARBECUE WITH A STEADY WATER STREAM SUCH AS FROM A GARDEN HOSE OR POWER WASHER. ELECTRONIC COMPONENTS COULD BECOME DAMAGED.

FOIL PANS
Perfect for lining the catch pan to make cleanup convenient and easy.

BARBECUE BRUSH
A must-use before you even dream of barbecuing. A quick once-over on hot grates prevents the charred remains of meals past from sticking to your meals present.

MAIN BURNER(S) or SIDE BURNER WILL NOT IGNITE

SYMPTOM

- Main burners or side burner do(es) not ignite when following the electronic ignition instructions in the “Operation” section of this owner’s manual.

CAUSE

There is a problem with gas flow.

SOLUTION

If any burner does not ignite, the first step is to determine if there is gas flowing to the burner(s). To check this, follow the instructions below for “Lighting Your Barbecue with a Match.”

If **match lighting IS NOT successful**, follow the “GAS FLOW” troubleshooting suggestions on the next page.

There is a problem with the electronic ignition system.

If any burner does not ignite, the first step is to determine if there is gas flowing to the burner(s). To check this, follow the instructions below for “Lighting Your Barbecue with a Match.”

If **match lighting IS successful**, follow the instructions for “Checking the Components of the Electronic Ignition System.”

Lighting Your Barbecue with a Match

Using a Match to Determine if there is Gas Flow to the Main Burners

- 1) Open the barbecue lid.
- 2) Check that all burner control knobs (including side burner control knob) are in the off \circ position. Check by pushing in and turning knobs clockwise.
- 3) Confirm that gas supply is connected.
- 4) Begin with the burner furthest to the left. Put match in the matchstick holder and strike match. (Matchstick holder is located under left side table.) Insert a lit match down through the cooking grills, past the FLAVORIZER BARS and next to the burner (A).
- 5) Push the burner control knob in and slowly turn it anti-clockwise toward the start/high \bullet position.
- 6) Check that the burner is lit by looking through the cooking grills and through the cutout in the FLAVORIZER bar.
- 7) If the burner does not ignite within 4 seconds, turn burner control knob to the off \circ position and wait five minutes to allow the gas to clear before attempting to light the burner again. If repeated attempts fail, follow the gas flow troubleshooting instructions on the next page.
- 8) If the burner ignites, the problem lies in the ignition system. Follow the instructions for “Checking the Components of the Electronic Ignition System”.
- 9) Repeat the process on all main burners as required.
- 10) Replace the matchstick holder by hanging underneath left side table (B).

Using a Match to Determine if there is Gas Flow to the Side Burner

- 1) Open the side burner lid.
- 2) Check that all burner control knobs (including side burner control knob) are in the off \circ position. Check by pushing in and turning knobs clockwise.
- 3) Confirm that gas supply is connected.
- 4) Put match in the matchstick holder and strike match. (Matchstick holder is located under left side table.) Hold lit match by the side burner (C).
- 5) Push the side burner control knob in and slowly turn it anti-clockwise toward the start/high \bullet position.
- 6) Check that the side burner is lit. The side burner flame may be difficult to see on a bright sunny day.
- 7) If the side burner does not ignite within 4 seconds, turn side burner control knob to the off \circ position and wait five minutes to allow the gas to clear before attempting to light the burner again. If repeated attempts fail, follow the gas flow troubleshooting instructions on the next page.
- 8) If the burner ignites, follow the instructions for “Checking the Components of the Electronic Ignition System”.

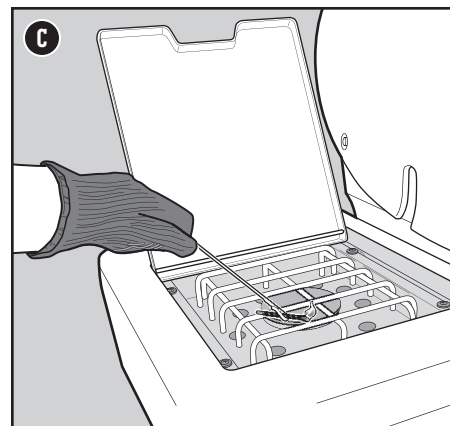
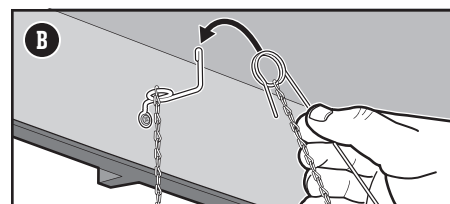
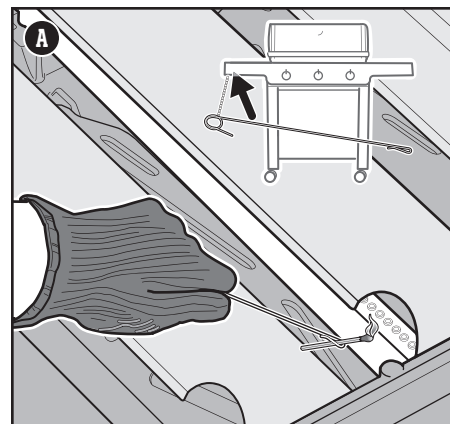

REPLACEMENT PARTS

To obtain replacement parts, contact the local retailer in your area or log onto weber.com.

GAS FLOW

SYMPTOM

- Barbecue does not reach desired temperature or heats unevenly.
- One or more of the burners fail to ignite.
- Flame is low when burner is on high position.
- Flames do not run the whole length of the burner.
- Burner flame pattern is erratic.

CAUSE

SOLUTION

Fuel hose is bent or kinked.

Straighten fuel hose.

Burner ports are dirty.

Clean burner ports. Refer to "Cleaning the Burner Ports."

SYMPTOM

- Gas is smelled in conjunction with burner flames that appear yellow and lazy.

CAUSE

SOLUTION

Spider screens on the burners are obstructed.

Clean spider screens. Refer to "Cleaning the Spider Screens" in the Product Care section. Also refer to the illustrations and information in this section about proper flame pattern and spider screens.

Proper Burner Flame Pattern

The burners in your barbecue were factory set for the correct air and gas mixture. When the burners are performing correctly, you will see a specific flame pattern. The tips may occasionally flicker yellow (A), with a descending light blue (B) to dark blue flame (C).

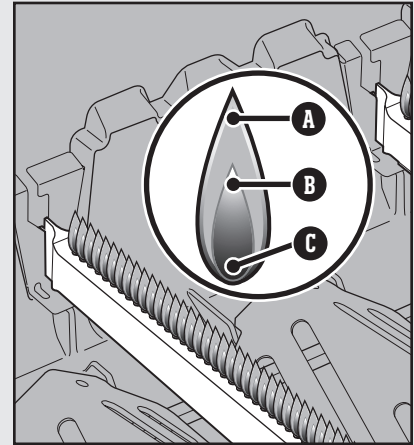

Spider Screens

The combustion air openings of the burners (D) are fitted with stainless steel screens to prevent spiders and other insects from spinning webs and building nests inside the burners. Dust and debris can accumulate on the outside of the spider/insect screen and obstruct the oxygen flow to the burners.

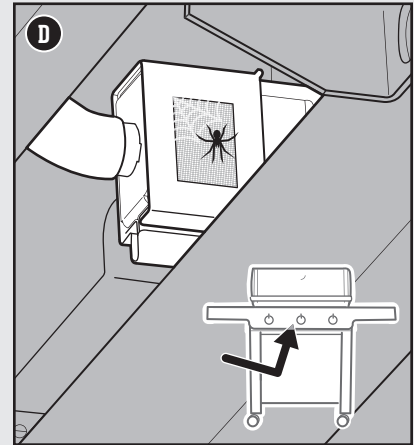

⚠ **WARNING:** Do not attempt to make any repair to gas carrying, gas burning, ignition components or structural components without contacting Weber-Stephen Products LLC, Customer Service Department.

⚠ **WARNING:** Failure to use genuine Weber-Stephen parts for any repair or replacement will void all warranty protection.

⚠ **CAUTION:** The burner tube openings must be positioned properly over the valve orifices.

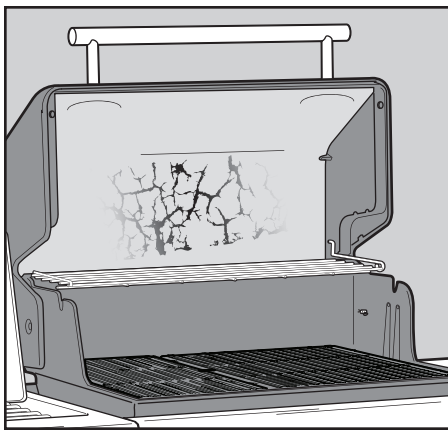

GREASY BARBECUE (Peeling Paint & Flare-Ups)

SYMPTOM

- Inside of lid appears to have the appearance of peeling paint.

CAUSE

The flakes you see are accumulated cooking vapours that have turned into carbon.

SOLUTION

This happens over time after repeated use of your barbecue. This is not a defect. Clean the lid. Refer to the "Product Care" section.

SYMPTOM

- Experiencing flare-ups when barbecuing or preheating.

CAUSE

There is leftover food from the previous meal.

SOLUTION

Always preheat the barbecue on the highest setting for 10 to 15 minutes.

The inside of the barbecue needs to be cleaned thoroughly.

Follow the steps in the "Cleaning and Maintenance" section to clean the barbecue inside from the top down.

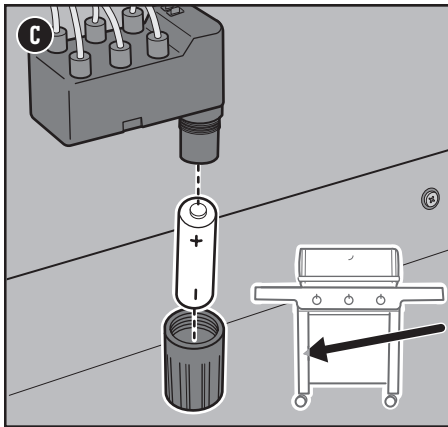

Checking the Components of the Electronic Ignition System

When pressing the ignition button you should hear a ticking sound. If you cannot hear the ticking sound, check the battery, then check the wires. Remove the heat shield to check these components.

Checking the Battery

There are three potential issues with the battery that supplies the power to your ignition module that need to be checked:

- 1) Some batteries have a plastic protective wrap around them. (Do not confuse this plastic with the battery label.) Check that this plastic wrap is removed.
- 2) Confirm that the battery is installed correctly (C).
- 3) If the battery is old, replace it with a new battery.

Checking the Wires

There are two potential trouble spots that need to be checked:

- 1) Check that the ignition wires are connected securely to the terminals on the ignition button under the control panel.
- 2) Make sure the ignition wires are properly attached to the ignition module. The wire terminals are colour coded to correspond with the terminals on the ignition module. The number of wires will vary per model.

NOTE: Reinstall the heat shield to the ignition module.

CALL CUSTOMER SERVICE

If you are still experiencing any problems, contact the Customer Service Representative in your area using the contact information on weber.com.

335 Igniter Module Wire Chart

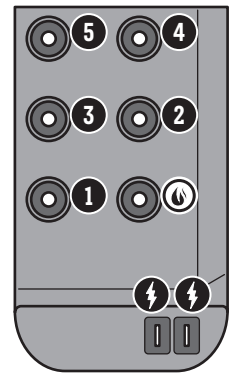
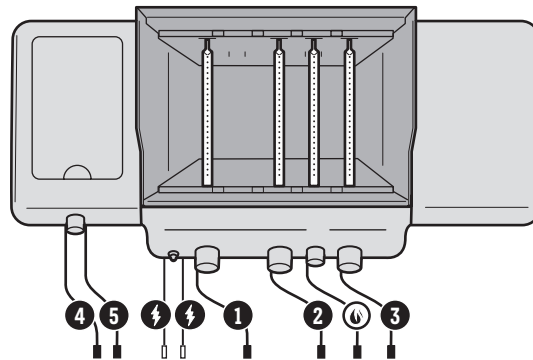

435 Igniter Module Wire Chart

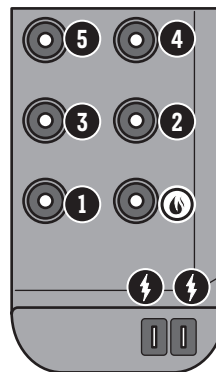
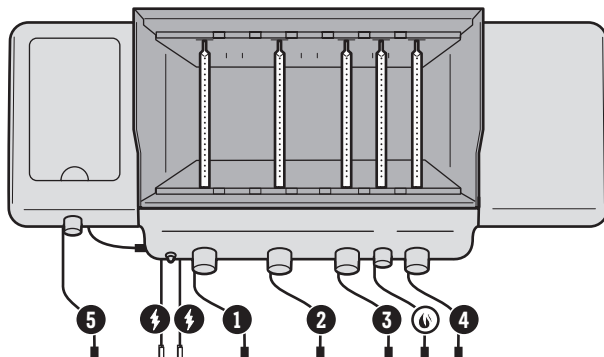

Checking the Earthed Wire

Models 425s and 435 have an earthed wire connected to the manifold bracket. This is visible from beneath the control panel (D):

- 1) Check that the earthed wire is properly secured with a screw.

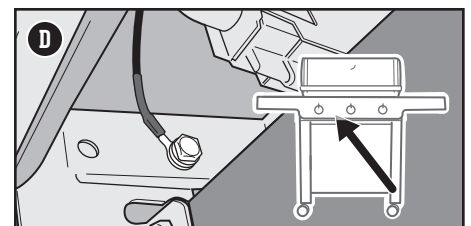

LOSS OF POWER

SYMPTOM

• **WEBER CONNECT module and control knob lights do not turn on.**

CAUSE

SOLUTION

Wires are disconnected.

Check that all of the wires are connected securely to the terminals on the back of the WEBER CONNECT module and to the control board under the side table. Refer to the "WEBER CONNECT Wire Chart".

Power cord is disconnected.

Check that the power cord is plugged into the port beneath the side table and to the wall outlet. Check that the switch beneath the side table is turned on. Refer to "Check the Power Cord".

The fuse has blown.

If the barbecue will still not power on after you have completed the above checks, it is likely that the fuse has blown. For instructions on how to replace the barbecue's fuse, refer to "Fuse Replacement".

Alternative external power bank may be depleted.

If you are using an optional external power bank, sold separately, disconnect it from the control board and check the manufacturer's operating guide for information on recharging. Refer to "Connecting an External Power Bank".

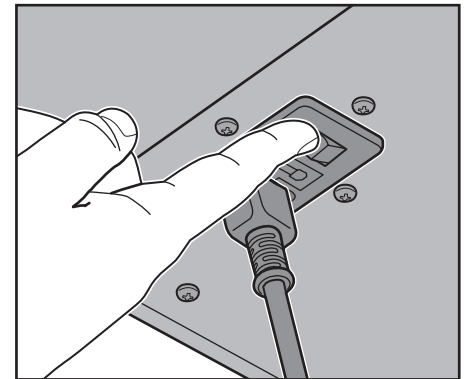
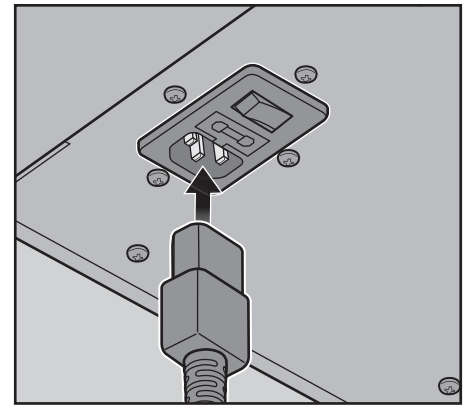

WEBER CONNECT IS EXPERIENCING CONNECTIVITY ISSUES

SYMPTOM

• **Bluetooth® is having trouble maintaining connectivity or pairing with a smart device.**

CAUSE

SOLUTION

Bluetooth® is a short range signal only.

When the WEBER CONNECT module is on, it is ready to pair. Make sure that Bluetooth® on the smart device is turned on and that the device is near the barbecue.

Bluetooth® has already paired to another smart device.

If the Bluetooth® indicator light is on but is not flashing, it means that it is already paired to a smart device. Turn off Bluetooth® on any smart device that you do not wish to have paired to the barbecue.

SYMPTOM

• **Wi-Fi is having trouble maintaining connectivity with a Wi-Fi network.**

CAUSE

SOLUTION

Barbecue is out of range of the Wi-Fi network signal.

In order to successfully connect your smart device to your local Wi-Fi network, your barbecue must be within range of your Wi-Fi router. If your attempts to connect have been unsuccessful, try moving the barbecue within range of the Wi-Fi router or adding a signal extender for a stronger signal.

ERROR CODE APPEARS ON DISPLAY

SYMPTOM

• **During start-up or barbecuing, an error code appears on the digital display.**

CAUSE

SOLUTION

The WEBER CONNECT module is a device that is sensitive to certain external factors. Variations in power supply or radio frequency may affect operation.

Contact the Customer Service Representative in your area using the contact information on weber.com.

Replacing Batteries for the Barbecue Lighting

Use alkaline batteries only. Do not mix old and new batteries or different types of batteries (standard, alkaline, or rechargeable). If you do not plan to use the barbecue for a month or more, remove the batteries.

- 1) Close the lid. Locate the battery housing on the side of the lid handle and unscrew the cap (A). Do not change batteries with the lid open.
- 2) Remove the battery sleeve.
- 3) Replace three size C batteries (B).
- 4) Line up graphic indicators (C) on the sleeve and handle as you reinstall the sleeve. Tighten cap.

NOTE: Periodically wipe the lenses with a damp cloth to keep the lights illuminating brightly.

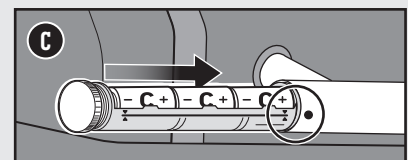
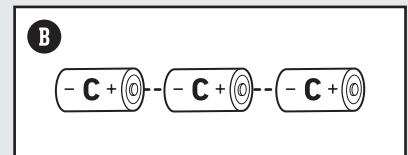
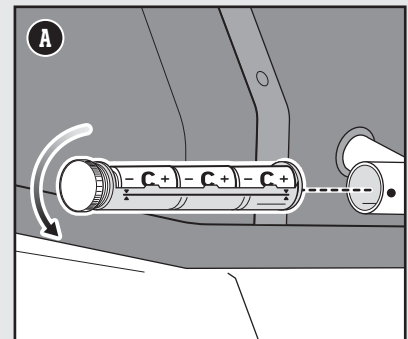

Fuse Replacement

If your WEBER CONNECT module is non-responsive even after securing all electrical connections, it is possible that the barbecue's fuse has blown. The barbecue's power supply utilises a cartridge fuse. This simple and inexpensive part can be easily replaced with the following instructions:

CAUTION: Only use the properly sized and rated fuse when replacing. Failure to do so will void your warranty. The correct fuse is:

1.6A

250V

5x20mm

Fast blow

1. Make sure that the barbecue is completely cool, then power off and unplug the barbecue from the power source **(A)**.
2. The fuse is installed inside the fuse holder located on the underside of the side table. Use a flathead screwdriver to gently pry open the fuse holder and remove the fuse **(B)**.

NOTE: WEBER recommends replacing the fuse if there is suspicion of failure.

3. Install a new fuse into the fuse holder and reinstall the fuse holder into the power module **(C)**.

CAUTION: Make sure the fuse holder is fully installed and closed before operating your barbecue.

4. Plug in, and power on the switch to allow the module to run.

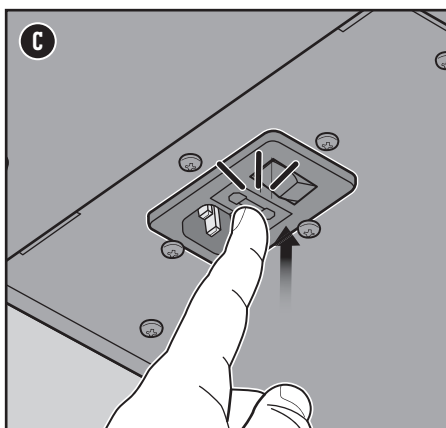
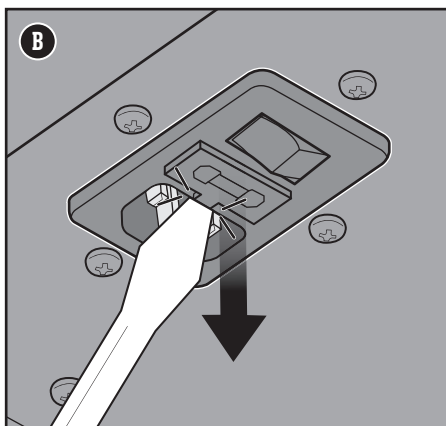
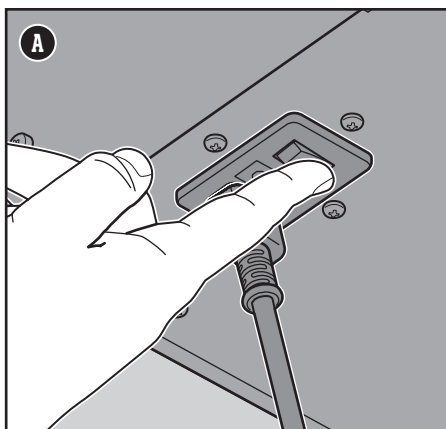

Auxiliary Power Input

Connecting an External Power Bank

As an alternative to using an AC wall outlet to power the WEBER CONNECT Module during your cooking session, you can instead connect an external rechargeable power bank, sold separately.

The power bank should have a minimum capacity of 10,000 mA hours with a 5-volt USB-A connector. Due to the low power draw of the Genesis Smart barbecue when using a rechargeable power bank, you must use the USB-A port on the power bank for the USB-C input on the barbecue, using a USB-A to USB-C cable, sold separately.

The shelf under the side table can accept a power bank with maximum dimensions of 4" wide x 7" deep x 1.25" high.

The WEBER CONNECT module will draw power automatically from the power bank if the AC power is lost or unplugged. The power supply switch only controls the current from the wall outlet to the barbecue.

- 1) Using a USB-A to USB-C cable, connect the cable to the USB-A port on the power bank (A).
- 2) Remove the silicone dust cap from the control board. Connect the cable to the USB-C port on the control board (B).
- 3) Confirm that the power bank is on.
- 4) Place the power bank on the small shelf beneath the side table (C).

See the manufacturer's operating guide for instructions on fully charging the power bank.

Additional information regarding the use of a power bank:

- Do not plug the power bank into an exterior outlet while it is connected to the barbecue.
- Disconnect the power bank from the barbecue and bring it indoors after use. Reinsert the silicone dust cap over the USB-C port on the control board (D).
- The power bank will not supply power to the burner igniters. Refer to "Checking the Components of the Electronic Ignition System".
- The USB-C connector on the control board is for input power only and does not provide output power.
- The USB-C connector on the control board is not for data transmission.
- Do not store the power bank outdoors.
- Fully recharge the power bank before each use. The battery level of the power bank is not monitored by the barbecue.
- Use only if the outdoor temperature is between 10°F (-12°C) and 100°F (38°C), unless the power bank is rated for higher and/or lower temperature conditions. Follow the manufacturer's operating guidelines.

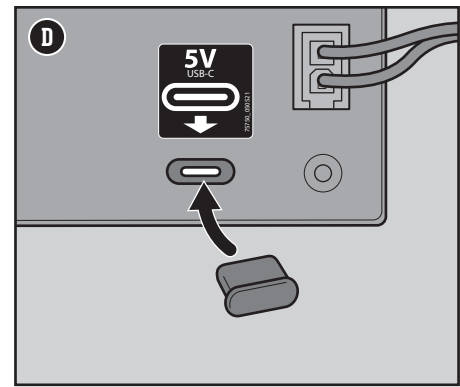
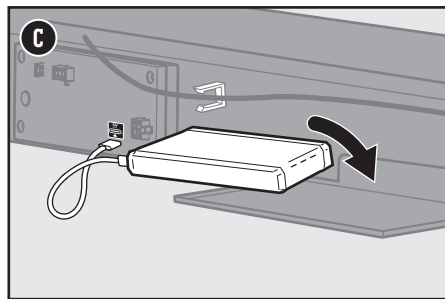
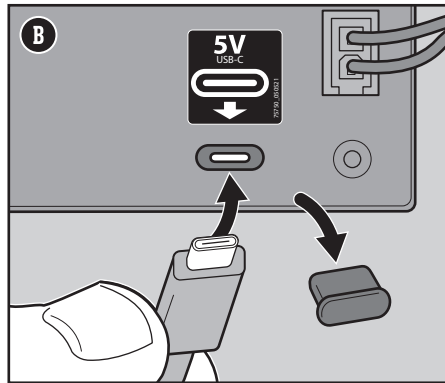
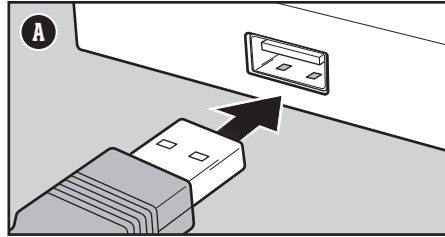
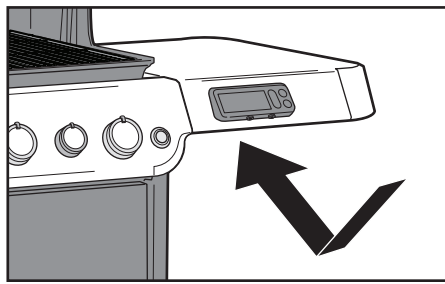



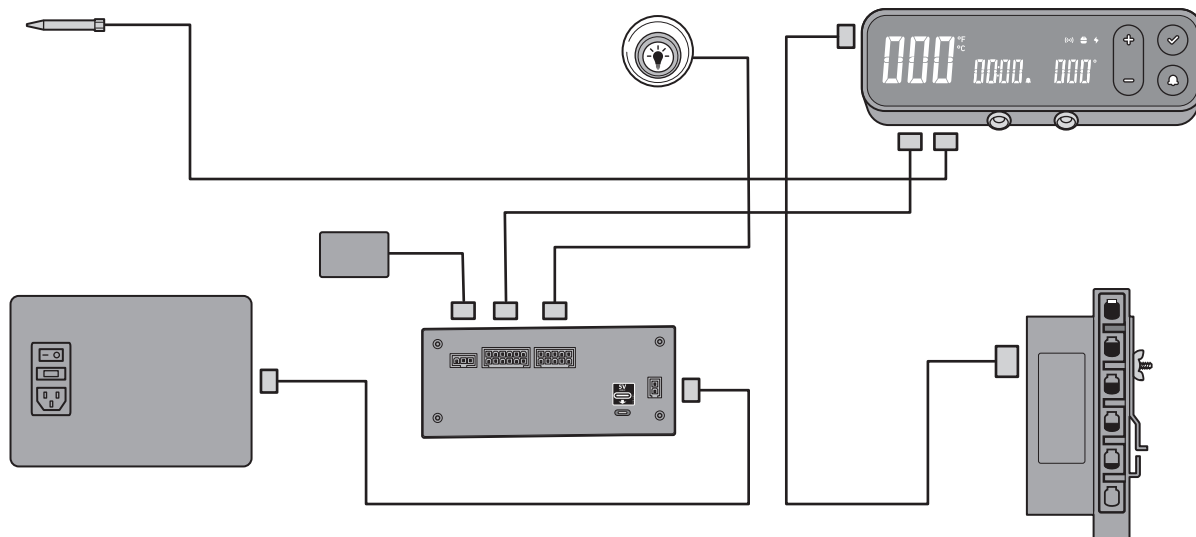

WEBER CONNECT Wire Chart



Some features listed are only available on select models.

Barbecuing Guide

Type	Thickness/Weight	Approximate Total Barbecue Time
 RED MEAT		
	19 mm thick	4 to 6 minutes direct high heat
Steak: Sirloin strip, Porterhouse, rib-eye, T-bone, and beef fillet steak (tenderloin)	25 mm thick	6 to 8 minutes direct high heat
	50 mm thick	14 to 18 minutes sear for 6 to 8 minutes direct high heat, then for 8 to 10 minutes indirect high heat
Flank Steak	0.68 to 0.90 kg, 19 mm thick	8 to 10 minutes direct medium heat
Minced Beef Patty	19 mm thick	8 to 10 minutes direct medium heat
Whole beef fillet	1.3 to 1.8 kg	45 to 60 minutes 15 minutes direct medium heat, then 30 to 45 minutes indirect medium heat
 PORK		
Bratwurst: fresh	85 g link	20 to 25 minutes direct low heat
	19 mm thick	6 to 8 minutes direct high heat
Chop: boneless or bone in	31 to 38 mm thick	10 to 12 minutes sear 6 minutes direct high heat, then 4 to 6 minutes indirect high heat
Ribs: baby back, spareribs	1.3 to 1.8 kg	1½ to 2 hours indirect medium heat
Ribs: country-style, bone in	1.3 to 1.8 kg	1½ to 2 hours indirect medium heat
Whole beef fillet	0.454 kg	30 minutes sear 5 minutes direct high heat, then 25 minutes indirect medium heat
 POULTRY		
Chicken Breast: boneless, skinless	170 to 226 g	8 to 12 minutes direct medium heat
Chicken Thigh: boneless, skinless	113 g	8 to 10 minutes direct medium heat
Chicken Pieces: bone in, assorted	85 to 170 g	36 to 40 minutes 6 to 10 minutes direct low heat, then 30 minutes indirect medium heat
Chicken: whole	1.8 - 2.2 kg	1 to 1½ hours indirect medium heat
Cornish Game Hen	0.68 - 0.90 kg	60 to 70 minutes indirect medium heat
Turkey: whole, unstuffed	4.5 - 5.4 kg	2 to 2½ hours indirect medium heat
 SEAFOOD		
Fish, Fillet, or Steak: halibut, red snapper, salmon, sea bass, swordfish, and tuna	6 to 13 mm thick	3 to 5 minutes direct medium heat
	25 - 31 mm thick	10 to 12 minutes direct medium heat
Fish: whole	0.454 kg	15 to 20 minutes indirect medium heat
	1.36 kg	30 to 45 minutes indirect medium heat
Prawn	42.5 g	2 to 4 minutes direct high heat
 VEGETABLES		
Asparagus	12.7 mm in diameter	6 to 8 minutes direct medium heat
Corn	in husk	25 to 30 minutes direct medium heat
	husk removed	10 to 15 minutes direct medium heat
Mushrooms	shiitake or button	8 to 10 minutes direct medium heat
	portobello	10 to 15 minutes direct medium heat
Onion	halved	35 to 40 minutes indirect medium heat
	12.7 mm slices	8 to 12 minutes direct medium heat
Potatoes	whole	45 to 60 minutes indirect medium heat
	12.7 mm slices	9 to 11 minutes parboil 3 minutes, then 6 to 8 minutes direct medium heat

The cuts, thicknesses, weights, and barbecuing times above are meant to be guidelines. Factors such as altitude, wind and outside temperature can affect cooking times. Two rules of thumb: Barbecue steaks, fish fillets, boneless chicken pieces, and vegetables using the direct method for the time given on the chart (or to the desired doneness), turning food once halfway through barbecuing time. Barbecue roasts, whole poultry, bone-in poultry pieces, whole fish and thicker cuts using the indirect method for the time given on the chart (or until an instant-read thermometer registers the desired internal temperature). Cooking times for beef and lamb are to medium doneness unless otherwise noted. Before carving, let roasts, larger cuts of meat, and thick chops and steaks rest for 5 to 10 minutes after cooking. The internal temperature of the meat will rise by 5 to 10 degrees during this time.

GENESIS SE-EPX-335 · SE-SPX-335

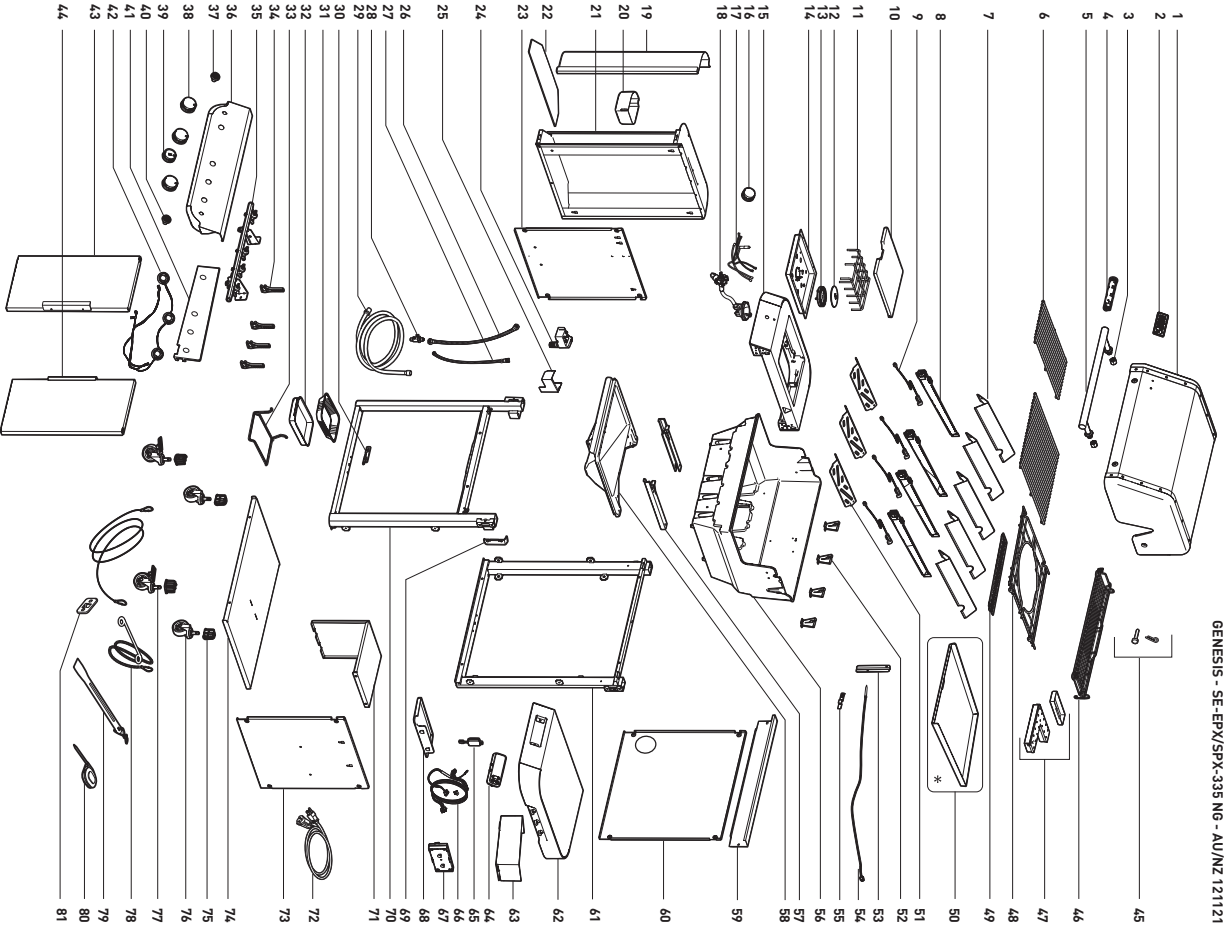

* This item is packaged separately at retail.

GENESIS SE-EPX-435 · SE-SPX-435

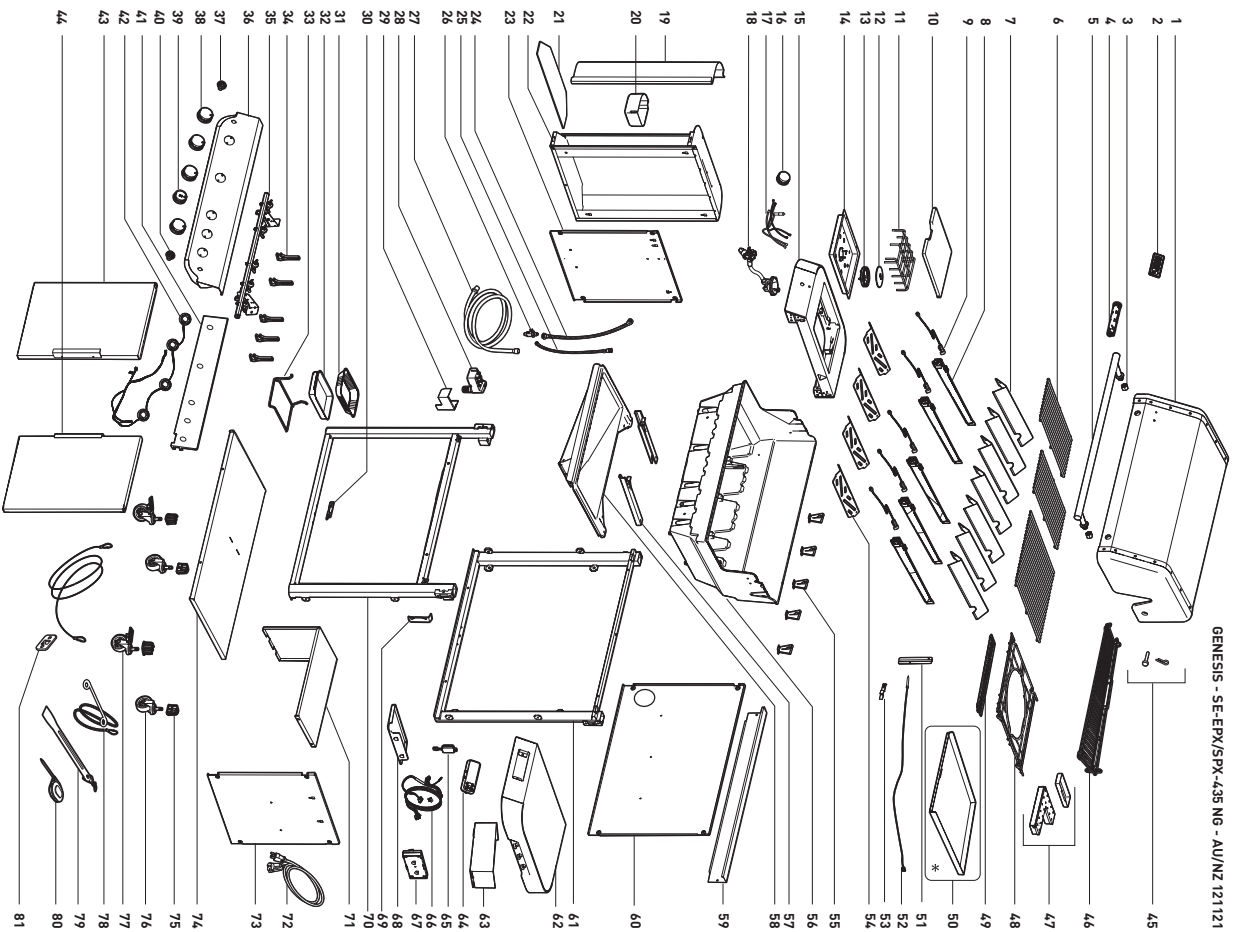

* This item is packaged separately at retail.



Weber-Stephen Products (Aust) Pty Ltd.

Level 1, 142-144 Fullarton Road
ROSE PARK SA 5067 AUSTRALIA
+61 8 8221 6111 | www.weberbbq.com.au

WEBER New Zealand ULC

86 East Highbrook Drive
East Tamaki, Auckland 2013 NEW ZEALAND
+64 9 279 7133 | www.WEBERnz.co.nz

Compliance Statements for WC2 CONTROLLER

FCC Compliance: This equipment has been tested and found to comply with the limits for a Class B digital device, pursuant to part 15 of the FCC rules. These limits are designed to provide reasonable protection against harmful interference in a residential installation. This equipment generates, uses and can radiate radio frequency energy and, if not installed and used in accordance with the instructions, may cause harmful interference to radio communications. However, there is no guarantee that interference will not occur in a particular installation. If this equipment does cause harmful interference to radio or television reception, which can be determined by turning the equipment off and on, the user is encouraged to try to correct the interference by one or more of the following measures: (1) Reorient or relocate the receiving antenna. (2) Increase the separation between the equipment and receiver. (3) Connect the equipment into an outlet on a circuit different from that to which the receiver is connected. (4) Consult the manufacturer, dealer or an experienced radio/TV technician for help. Changes or modifications not expressly approved by Weber could void the user's authority to operate this device.

FCC Radio Frequency (RF) Exposure: This equipment complies with FCC and ISED Canada radiation exposure limits set forth for an uncontrolled environment. The user should avoid prolonged exposure within 20cm of the antenna, which may exceed the FCC or RSS-102 radio frequency exposure limits.

IC Compliance: This device contains license-exempt transmitter(s)/receiver(s) that comply with Innovation, Science and Economic Development Canada's license-exempt RSS(s). Operation is subject to the following two conditions: (1) This device may not cause interference; and (2) This device must accept any interference, including interference that may cause undesired operation of the device.

IFETEL Compliance: Operation of this unit is subject to the following two conditions: (1) this unit or device may not cause harmful interference, and (2) this unit or device must accept any interference, including interference that may cause undesired operation.

CAN ICES-3B/NMB-3B

FCC: 2AHSR-NBE2N001

IC: 21267-NBE2N001

HVIN: WC2 Controller / PMN WC2 Controller



Model: GEN1

Apple and the Apple logo are trademarks of Apple Inc., registered in the U.S. and other countries. App Store is a service mark of Apple Inc. Android is a trademark of Google LLC. Google Play and the Google Play logo are trademarks of Google LLC.

The Bluetooth® word mark and logos are registered trademarks owned by Bluetooth SIG, Inc. and any use of such marks by Weber-Stephen Products LLC is under license. Other trademarks and trade names are those of their respective owners.