

GENESIS



E-335 • S-335
E-435

LPG Owner's Manual



REGISTER TODAY

We are so glad that you have joined us on the journey to barbecuing greatness. Register your barbecue and gain access to fun and engaging WEBER information, including tips, tricks and how to get the most out of your barbecuing experience.

Important: Read these instructions for use carefully so as to familiarize yourself with the appliance before connecting it to its gas container. Keep these instructions for future reference.

30505

101823
enZA

Important Safety Information

DANGER, WARNING, and CAUTION statements are used throughout this Owner's Manual to emphasise critical and important information. Read and follow these statements to help ensure safety and prevent property damage. The statements are defined below.

- ⚠ **DANGER:** Indicates a hazardous situation which, if not avoided, *will result in death or serious injury.*
- ⚠ **WARNING:** Indicates a hazardous situation which, if not avoided, *could result in death or serious injury.*
- ⚠ **CAUTION:** Indicates a hazardous situation which, if not avoided, *could result in minor or moderate injury.*

⚠ DANGER

If you smell gas:

- Shut off gas to the appliance (barbecue).
- Extinguish any open flame.
- Open lid.
- If odour continues, keep away from the appliance (barbecue) and immediately call your gas supplier or the emergency fire services.

⚠ WARNING

- Do not store or use gasoline or other flammable liquids or vapours in the vicinity of this (barbecue) or any other appliance.
- An LPG cylinder not connected for use shall not be stored in the vicinity of this (barbecue) or any other appliance.

USE OUTDOORS ONLY.

READ THE INSTRUCTIONS BEFORE USING THE APPLIANCE (BARBECUE).

NOTICE TO INSTALLER: These instructions must be left with the consumer.

NOTICE TO CONSUMER: Retain these instructions for future reference.

Installation and Assembly

- ⚠ **DANGER:** This barbecue is not intended to be installed in or on recreational vehicles or boats.
- ⚠ **WARNING:** Do not use this barbecue unless all parts are in place and the barbecue was properly assembled according to the assembly instructions.
- ⚠ **WARNING:** Do not build this model of barbecue in any built-in or slide-in construction.
- ⚠ **WARNING:** Do not modify the appliance. **LPG is not natural gas. The conversion or attempted use of natural gas in an LPG gas unit or LPG gas in a natural gas unit is unsafe and will void your warranty.**

- Any parts sealed by the manufacturer must not be altered by the user.

Operation

- ⚠ **DANGER:** Only use the barbecue outdoors in a well-ventilated area. Do not use in a garage, building, breezeway, tent, any other enclosed area, or beneath an overhead combustible structure.
- ⚠ **DANGER:** Do not use the barbecue in any vehicle or in any storage or cargo area of any vehicle. This includes, but is not limited to, cars, trucks, station wagons, mini-vans, sport utility vehicles, recreational vehicles, and boats.
- ⚠ **DANGER:** When in use, combustible materials should not be within 61 cm (24 inches) of the back or sides of the barbecue.
- ⚠ **DANGER:** Keep the cooking area clear of flammable vapours and liquids such as petrol, alcohol, etc., and combustible materials.
- ⚠ **DANGER:** This appliance must be kept away from flammable materials during use.
- ⚠ **DANGER:** Do not put a barbecue cover or anything flammable on, or in the storage area under the barbecue while it is in operation or is hot.
- ⚠ **DANGER:** Should a grease fire occur, turn off all burners and leave lid closed until fire is out.
- ⚠ **WARNING:** Accessible parts may be very hot. Keep young children away.
- ⚠ **WARNING:** The use of alcohol, prescription drugs, non-prescription drugs, or illegal drugs may impair the consumer's ability to properly and safely assemble, move, store, or operate the barbecue.
- ⚠ **WARNING:** Never leave the barbecue unattended during pre-heating or use. Exercise caution when using this barbecue. The entire cookbox gets hot when in use.
- ⚠ **WARNING:** Use heat-resistant barbecue mitts or gloves (conforming to EN 407, Contact Heat rating level 2 or greater) when operating barbecue.
- ⚠ **WARNING:** Do not move the appliance during use.
- ⚠ **WARNING:** Keep any electrical supply cord and the fuel supply hose away from any heated surfaces.
- ⚠ **CAUTION:** This product has been safety-tested and is only certified for use in a specific country. Refer to country designation located on outside of box.

- Do not use charcoal, briquettes or lava rock in the barbecue.

Storage and/or Nonuse

- ⚠ **WARNING:** Turn off the gas supply at the gas cylinder after use.
- ⚠ **WARNING:** LPG cylinders must be stored outdoors out of the reach of children and must not be stored in a building, garage or any other enclosed space.
- ⚠ **WARNING:** After a period of storage and/or nonuse, the barbecue should be checked for gas leaks and burner obstructions before use.
- Storage of the barbecue indoors is permissible only if the LPG cylinder is disconnected and removed from the barbecue.

HELLO!

We are so glad that you have joined us on the journey to barbecuing happiness. Please take some time to read through this Owner's Manual to ensure that you are up and barbecuing quickly and easily. We want to be with you for the life of your barbecue, so please take just a couple of minutes to register your barbecue. When you sign up for a WEBER account as part of your registration, we will deliver special barbecue-related content just for you to enjoy.

So, come along and join us online, on your smart device or however else you'd like to stay in touch.

Thank you for choosing WEBER. We are happy you are here.

TABLE OF CONTENTS

2	Welcome to WEBER Important Safety Information
4	The WEBER Promise
5	Product Features GENESIS Features High Performance Barbecuing
6	Getting Started Important Information about LP Gas & Gas Connections Installing the LPG Cylinder Connecting the LPG Cylinder and Leak Checking
12	Operation The Very First Time You Barbecue Every Time You Barbecue Igniting the Barbecue Using the Sear Zone Igniting the Side Burner
16	Tips and Hints The Flame - Direct or Indirect Discover What's Possible Barbecuing Do's and Don'ts Extra on the Side More Cooking Space
20	Product Care Cleaning and Maintenance
22	Troubleshooting
26	Barbecuing Guide
27	Replacement Parts

The WEBER Promise

At WEBER, we pride ourselves on two things: making barbecues that last and providing a lifetime of excellent customer service.

Thank you for purchasing a WEBER product. Weber-Stephen Products LLC, 1415 S. Roselle Road, Palatine, Illinois 60067 ("WEBER") prides itself on delivering a safe, durable, and reliable product.

This is WEBER's Voluntary Warranty provided to you at no extra charge. It contains the information you will need to have your WEBER product repaired in the unlikely event of a failure or defect.

Pursuant to applicable laws, the customer has several rights in case the product is defective. Those rights include supplementary performance or replacement, abatement of the purchasing price, and compensation. In the European Union, for example, this would be a two-year statutory warranty starting on the date of the handover of the product. These and other statutory rights remain unaffected by this warranty provision. In fact, this warranty grants additional rights to the Owner that are independent from statutory warranty provisions.

WEBER'S VOLUNTARY WARRANTY

WEBER warrants, to the purchaser of the WEBER product (or in the case of a gift or promotional situation, the person for whom it was purchased as a gift or promotional item), that the WEBER product is free from defects in material and workmanship for the period(s) of time specified below when assembled and operated in accordance with the accompanying Owner's Manual. (Note: If you lose or misplace your WEBER Owner's Manual, a replacement is available online at www.weber.com, or such country-specific website to which Owner may be redirected.) Under normal, private single family home or flat use and maintenance, Weber agrees within the framework of this warranty to repair or replace defective parts within the applicable time periods, limitations and exclusions listed below. TO THE EXTENT ALLOWABLE BY APPLICABLE LAW, THIS WARRANTY IS EXTENDED ONLY TO THE ORIGINAL PURCHASER AND IS NOT TRANSFERABLE TO SUBSEQUENT OWNERS, EXCEPT IN THE CASE OF GIFTS AND PROMOTIONAL ITEMS AS NOTED ABOVE.

OWNER'S RESPONSIBILITIES UNDER THIS WARRANTY

To ensure trouble-free warranty coverage, it is important (but it is not required) that you register your Weber product online at www.weber.com or such country-specific website to which you may be redirected. Please also retain your original sales receipt and/or invoice. Registering your WEBER product confirms your warranty coverage and provides a direct link between you and WEBER in case we need to contact you.

The above warranty only applies if the Owner takes reasonable care of the WEBER product by following all assembly instructions, usage instructions, and preventative maintenance as outlined in the accompanying Owner's Manual, unless the Owner can prove that the defect or failure is independent of non-compliance with the above-mentioned obligations. If you live in a coastal area, or have your product located near a pool, maintenance includes regular washing and rinsing of the exterior surfaces as outlined in the accompanying Owner's Manual.

WARRANTY HANDLING / EXCLUSION OF WARRANTY

If you believe that you have a part which is covered by this Warranty, please contact WEBER Customer Service using the contact information on our website (www.weber.com, or such country-specific website to which Owner may be redirected). WEBER will, upon investigation, repair or replace (at its option) a defective part that is covered by this Warranty. In the event that repair or replacement are not possible, Weber may choose (at its option) to replace the barbecue in question with a new barbecue of equal or greater value. WEBER may ask you to return parts for inspection, shipping charges to be pre-paid.

This WARRANTY lapses if there are damages, deteriorations, discolourations, and/or rust for which WEBER is not responsible caused by:

- Abuse, misuse, alteration, modification, misapplication, vandalism, neglect, improper assembly or installation, and failure to properly perform normal and routine maintenance;
- Insects (such as spiders) and rodents (such as squirrels), including but not limited to damage to burner tubes and/or gas hoses;
- Exposure to salt air and/or chlorine sources such as swimming pools and hot tubs/spas;
- Severe weather conditions such as hail, hurricanes, earthquakes, tsunamis or surges, tornadoes or severe storms.

The use and/or installation of parts on your WEBER product that are not genuine WEBER parts will void this Warranty, and any damages that result hereby are not covered by this Warranty. Any conversion of a gas barbecue not authorised by WEBER and not performed by a WEBER authorised service technician will void this Warranty.

PRODUCT WARRANTY PERIODS

Cookbox:
12 years, no rust through/burn through
(2 years paint excluding fading or discolouration)

Lid assembly:
12 years, no rust through/burn through
(2 years paint excluding fading or discolouration)

Stainless steel burner tubes:
10 years, no rust through/burn through

Stainless steel cooking grates:
10 years, no rust through/burn through

Stainless steel FLAVORIZER BARS:
10 years, no rust through/burn through

Porcelain-enamelled cast iron cooking grates:
10 years, no rust through/burn through

WEBER CONNECT Components:
3 years

All remaining parts:
5 years

DISCLAIMERS

APART FROM THE WARRANTY AND DISCLAIMERS AS DESCRIBED IN THIS WARRANTY STATEMENT, THERE ARE EXPLICITLY NO FURTHER WARRANTY OR VOLUNTARY DECLARATIONS OF LIABILITY GIVEN HERE WHICH GO BEYOND THE STATUTORY LIABILITY APPLYING TO WEBER. THE PRESENT WARRANTY STATEMENT ALSO DOES NOT LIMIT OR EXCLUDE SITUATIONS OR CLAIMS WHERE WEBER HAS MANDATORY LIABILITY AS PRESCRIBED BY STATUTE.

NO WARRANTIES SHALL APPLY AFTER THE APPLICABLE PERIODS OF THIS WARRANTY. NO OTHER WARRANTIES GIVEN BY ANY PERSON, INCLUDING A DEALER OR RETAILER, WITH RESPECT TO ANY PRODUCT (SUCH AS ANY "EXTENDED WARRANTIES"), SHALL BIND WEBER. THE EXCLUSIVE REMEDY OF THIS WARRANTY IS REPAIR OR REPLACEMENT OF THE PART OR PRODUCT.

IN NO EVENT UNDER THIS VOLUNTARY WARRANTY SHALL RECOVERY OF ANY KIND BE GREATER THAN THE AMOUNT OF THE PURCHASE PRICE OF THE WEBER PRODUCT SOLD.

YOU ASSUME THE RISK AND LIABILITY FOR LOSS, DAMAGE, OR INJURY TO YOU AND YOUR PROPERTY AND/OR TO OTHERS AND THEIR PROPERTY ARISING OUT OF THE MISUSE OR ABUSE OF THE PRODUCT OR FAILURE TO FOLLOW INSTRUCTIONS PROVIDED BY WEBER IN THE ACCOMPANYING OWNER'S MANUAL.

PARTS AND ACCESSORIES REPLACED UNDER THIS WARRANTY ARE WARRANTED ONLY FOR THE BALANCE OF THE ABOVE MENTIONED ORIGINAL WARRANTY PERIOD(S).

THIS WARRANTY APPLIES TO PRIVATE SINGLE FAMILY HOME OR FLAT USE ONLY AND DOES NOT APPLY TO WEBER BARBECUES USED IN COMMERCIAL, COMMUNAL OR MULTI-UNIT SETTINGS SUCH AS RESTAURANTS, HOTELS, RESORTS, OR RENTAL PROPERTIES.

WEBER MAY FROM TIME TO TIME CHANGE THE DESIGN OF ITS PRODUCTS. NOTHING CONTAINED IN THIS WARRANTY SHALL BE CONSTRUED AS OBLIGATING WEBER TO INCORPORATE SUCH DESIGN CHANGES INTO PREVIOUSLY MANUFACTURED PRODUCTS, NOR SHALL SUCH CHANGES BE CONSTRUED AS AN ADMISSION THAT PREVIOUS DESIGNS WERE DEFECTIVE.

Refer to International Business Units list at the end of this Owner's Manual for additional contact information.

**Weber-Stephen Products
(South Africa) (Pty) Ltd.**
141-142 Hertz Draai
Meadowdale, Edenvale
Gauteng
SOUTH AFRICA
TEL: +27 11 454 2369
info@weber.co.za



**PROTECT
YOUR
INVESTMENT**

Shield your barbecue from the elements with a heavy-duty premium barbecue cover.

GENESIS FEATURES

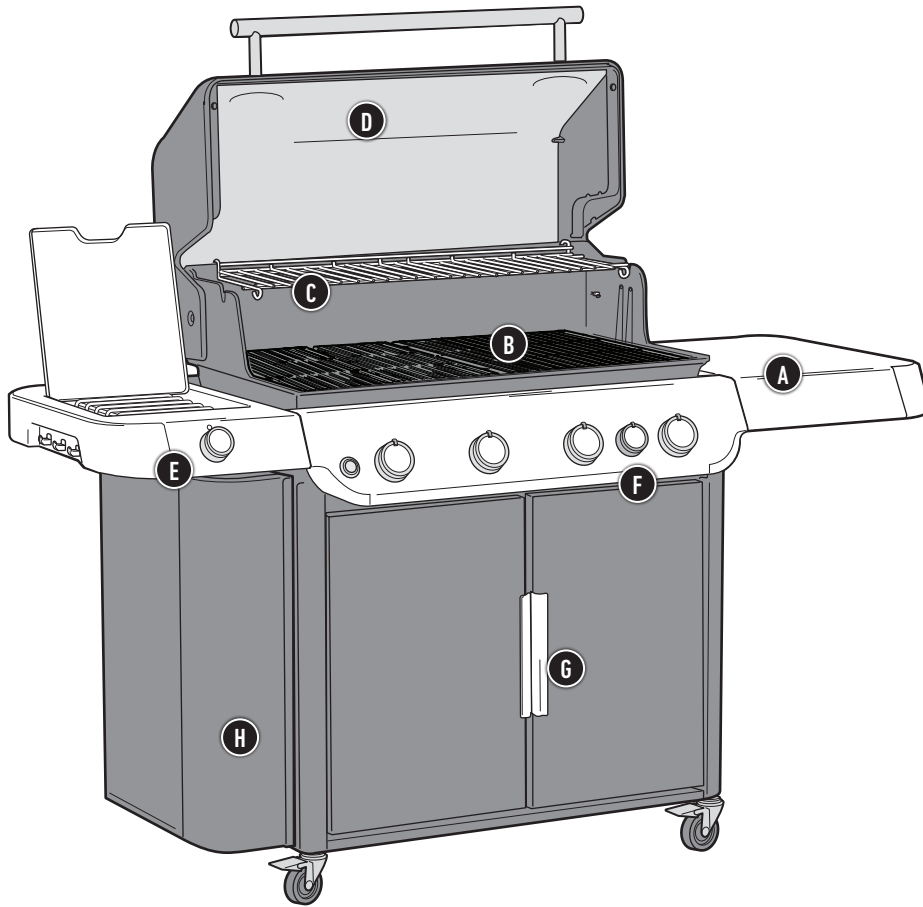

A Folding Prep & Serve Table

Use the side tables to keep platters, seasonings, and tools within arm's reach. Hang your essential barbecuing tools on the hooks for easy access and organisation of your backyard workspace. The right side table folds down to fit in smaller spaces.

B WEBER CRAFTED Outdoor Kitchen Collection Cooking Grates and Frame

Your barbecue is Outdoor Kitchen Collection Ready with the included cooking grates and frame. Additional WEBER CRAFTED grillware sold separately.

C Expandable Top Cooking Grate

Keeps food warm, or toasts buns, while the main course finishes barbecuing on the grate. Fold it out when you need a secondary cooking surface.

D Built-In Thermometer

Being aware of the temperature inside your barbecue allows you to adjust the heat when needed.

E Side Burner

Use the side burner to simmer BBQ sauce or sauté veggies while the main course barbecues under the lid.

F Sear zone

The Sear Zone is designed to create an intense heat zone to quickly add sear marks to your meat.

G Barbecue Cabinet

The barbecue cabinet adds enclosed storage space for all of your essential barbecuing tools and accessories.

H WEBER CRAFTED Barbecue Locker

Convenient side storage makes it easy to access all of your WEBER CRAFTED grillware.

HIGH PERFORMANCE BARBECUING

The high performance barbecuing system sets the standard in the world of gas barbecuing, and lands Weber in a class of its own. This powerful barbecuing system is based on over 65 years of barbecuing experience, culinary expertise, and most importantly, the wants and needs of the people who matter most – our barbecuing community. Each component was uniquely designed for ease-of-use and to provide an unequaled satisfaction to your backyard barbecuing experience.

1 INFINITY Ignition



The Infinity Ignition is guaranteed to ignite. Rest assured that you'll be up-and-barbecuing the first time, every time.

2 Burners

The unique, tapered shape delivers a consistent gas flow from front to back. This provides ultimate heat distribution, ensuring that food barbecues evenly and consistently anywhere on the cooking grates.

3 FLAVORIZER BARS

Stainless Steel FLAVORIZER BARS are angled just right to catch drippings that smoke and sizzle, adding that irresistible smoky flavour that we all know and love to your food.

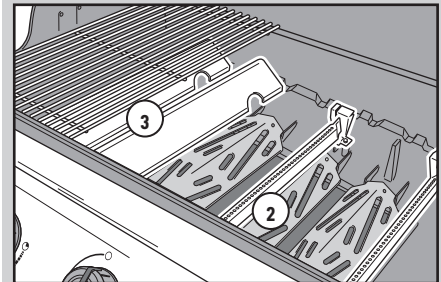

4 Grease Management System

Drippings that are not vapourised by the FLAVORIZER BARS are funnelled away from the burners into the disposable drip tray, located within the removable catch pan under the cookbox. Simply remove the catch pan and replace the drip tray as needed.

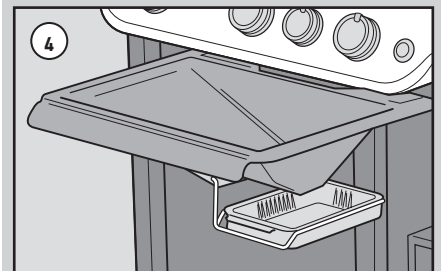

Important Information about LP Gas & Gas Connections

What is LPG?

Liquefied petroleum gas, also called LPG or LP gas, is the flammable, petroleum-based product used to fuel your grill. It is a gas at moderate temperatures and pressure when it is not contained. But at moderate pressure inside a container, such as a cylinder, LPG is a liquid. As pressure is released from the cylinder, the liquid readily vaporises and becomes gas.

Safe Handling Tips for LPG Cylinders

- A dented or rusty LPG cylinder may be hazardous and should be checked by your LP gas supplier. Do not use a cylinder with a damaged valve.
- Although your LPG cylinder may appear to be empty, gas may still be present, and the cylinder should be transported and stored accordingly.
- The LPG cylinder must be installed, transported, and stored in an upright, secure position. Cylinders should not be dropped or handled roughly.
- Never store or transport the LPG cylinder where temperatures can reach 51.7°C (125°F) (the cylinder will become too hot to hold by hand).

LPG Cylinder Requirements

- Use LPG cylinders with a minimum capacity of 9 kg.

What is a Regulator?

Your gas grill is equipped with a pressure regulator, which is a device to control and maintain uniform gas pressure as gas is released from the LPG cylinder.

Regulator and Hose Requirements

- The pressure regulator supplied with the grill must be used. This regulator is set for 2.8 kPa and complies with the requirements of SANS 1237.
- Avoid kinking the hose.
- Replacement regulator and hose assemblies must be as specified by Weber-Stephen Products LLC and SANS approved.

POL Connection

- A Hose
- B Regulator
- C Regulator Vent Hole (*point hole downward*)
- D POL coupling (*tighten anti-clockwise*)
- E LPG cylinder valve handwheel (*close clockwise*)

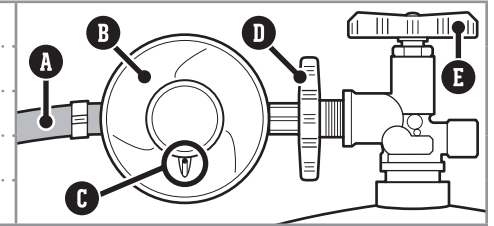

GENESIS Burner Valve Orifice Sizes & Consumption Data

		BURNER VALVE ORIFICE SIZES	
Country	Gas Category	335 Models	435 Models
China, Cyprus, Czech Republic, Denmark, Estonia, Finland, Hong Kong, Hungary, Iceland, India, Israel, Japan, Korea, Latvia, Lithuania, Malta, the Netherlands, Norway, Romania, Russia, Singapore, Slovakia, Slovenia, South Africa, Sweden, Turkey	I _{3B/P} (30 mbar or 2.8 kPa)	Main Burners 1.02 mm Sear Burner 1.02 mm Side Burner 1.02 mm	Main Burners 0.98 mm Sear Burner 0.98 mm Side Burner 1.02 mm
Belgium, France, Great Britain, Greece, Ireland, Italy, Luxembourg, Portugal, Spain, Switzerland	I _{3A} (28-30/37 mbar)	Main Burners 0.94 mm Sear Burner 0.94 mm Side Burner 0.96 mm	Main Burners 0.92 mm Sear Burner 0.92 mm Side Burner 0.96 mm
Poland	I _{3B/P} (37 mbar)	Main Burners 0.94 mm Sear Burner 0.94 mm Side Burner 0.96 mm	Main Burners 0.92 mm Sear Burner 0.92 mm Side Burner 0.96 mm
Austria, Germany	I _{3B/P} (50 mbar)	Main Burners 0.86 mm Sear Burner 0.86 mm Side Burner 0.85 mm	Main Burners 0.84 mm Sear Burner 0.84 mm Side Burner 0.85 mm

CONSUMPTION DATA		
Gas Category	335 Models	435 Models
I _{3B/P} (30 mbar or 2.8 kPa)	18.7 kW Propane	21.1 kW Propane
	21.6 kW Butane	24.5 kW Butane
I _{3A} (28-30/37 mbar)	1336 g/h Propane	1505 g/h Propane
	1572 g/h Butane	1784 g/h Butane
I _{3B/P} (37 mbar)	18.7 kW Propane	21.1 kW Propane
	21.6 kW Butane	24.5 kW Butane
I _{3B/P} (50 mbar)	1336 g/h Propane	1505 g/h Propane
	1572 g/h Butane	1784 g/h Butane

△ **IMPORTANT:** We recommend that you replace the gas hose assembly on your gas barbecue every five years. Some countries may have requirements that the gas hose be replaced within less than five years, in which case that country's requirement would take precedence.

For replacement hose, regulator, and valve assemblies, contact the Customer Service Representative in your area using the contact information on our web site.
Log on to weber.com.

Installing the LPG Cylinder

Cabinet Requirements

The LPG cylinder must fit inside the barbecue cabinet. The maximum size requirements for cylinders installed inside the cabinet are:

Cylinder Capacity:	13 kg maximum
Cylinder Height:	587 mm maximum
Cylinder Width:	289 mm maximum (rectangular footprint) or 318 mm maximum (round footprint)

The base of the cylinder must fit within the tank holder and rest flat on the bottom.

Several possible cylinder models approved for installation inside the cabinet are illustrated, with dimensions included.

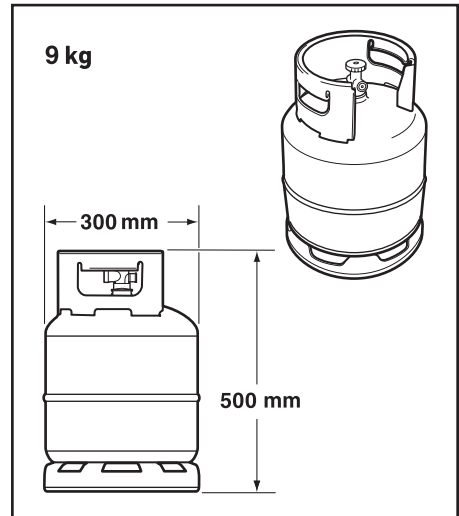
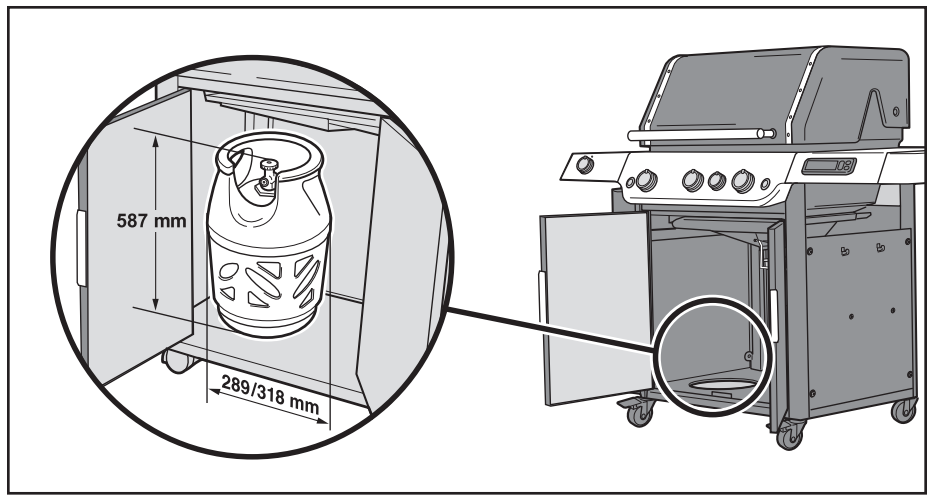

⚠ WARNING: Do not use an LPG cylinder if it does not meet the cylinder size requirements for placement inside the cabinet.

Prepare to Install the LPG Cylinder

The gas hose must be secured to the side panel with the supplied hose retention bracket.

- 1) Open cabinet doors.
- 2) Slide hose retention bracket (A) along hose to align with mounting tab inside left panel. Secure with one Phillips head screw.

LPG Cylinder Installation

- 1) Lift and place the cylinder into the cylinder holder (B) on the bottom panel. The base of the cylinder must fit within the cylinder holder.
- 2) Turn the cylinder so the valve opening faces the front of the barbecue.
- 3) Secure the cylinder with the cylinder strap (C).
- 4) Connect the regulator to the LPG cylinder. Refer to "CONNECT THE REGULATOR TO THE CYLINDER."

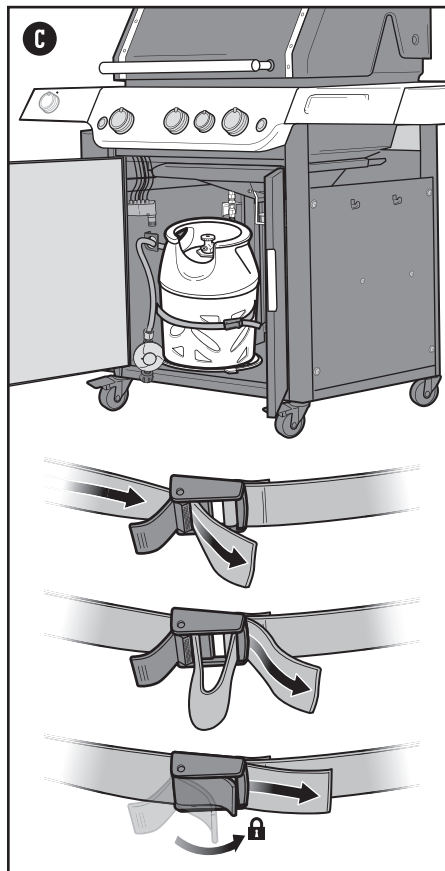
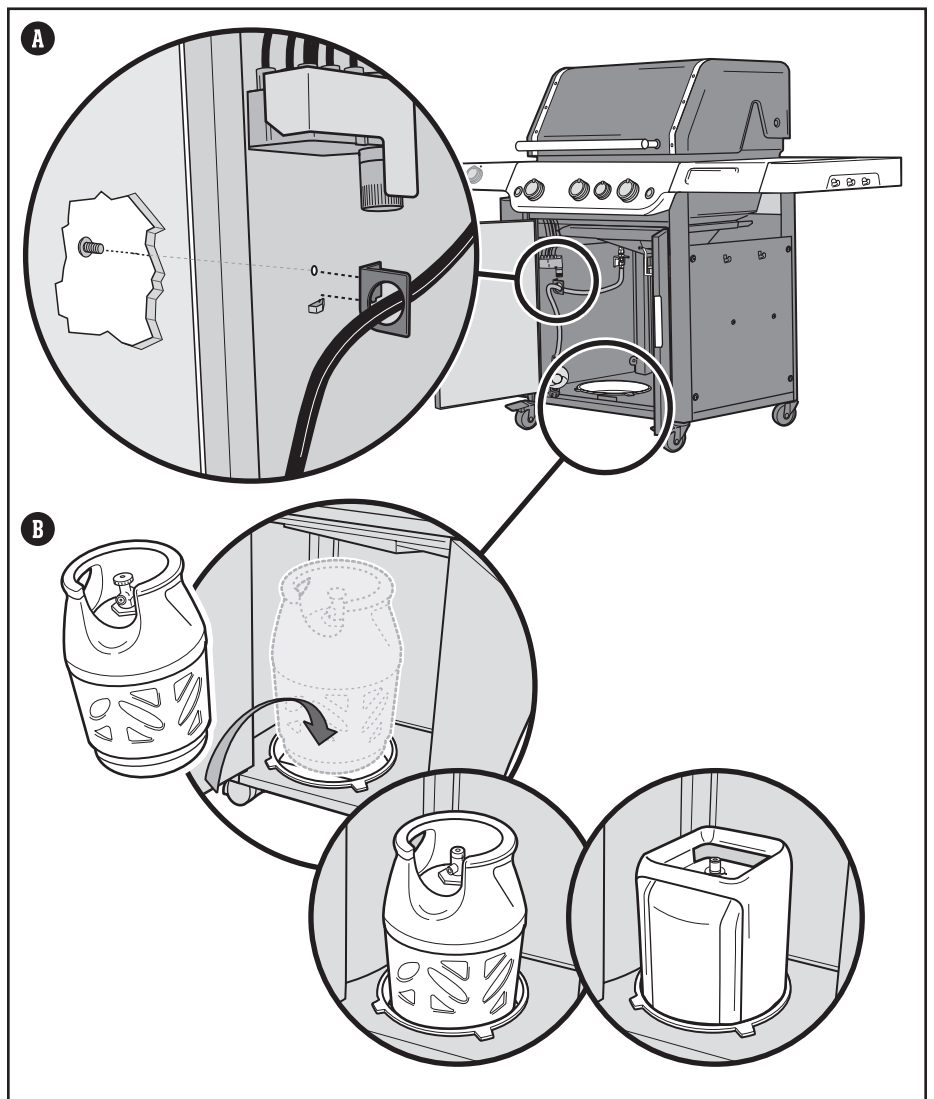

⚠ WARNING: The hose must be secured to the side panel with the hose retention bracket. Failure to do so could cause damage to the hose resulting in a fire or explosion, which can cause serious bodily injury or death, and damage to property.

Maximum LPG cylinder capacity INSIDE cabinet is 13 kg.

The length of hose must not exceed 1.5 metres.

Connecting the LPG Cylinder & Leak Checking

Connect the Regulator to the Cylinder

- 1) Confirm that the LPG cylinder valve is closed by turning valve clockwise.
- 2) Check that all burner control knobs (including side burner control knob) are in the off \circ position. Check by pushing in and turning knobs clockwise (A).
- 3) Connect the regulator to the LPG cylinder by screwing the POL coupling into the LPG cylinder valve, turning anti-clockwise (B). Hand-tighten only. Position the regulator so that the vent hole faces down.

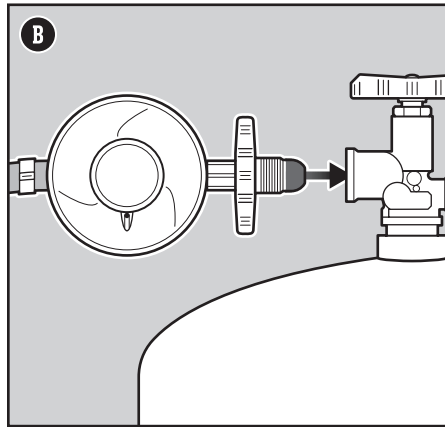
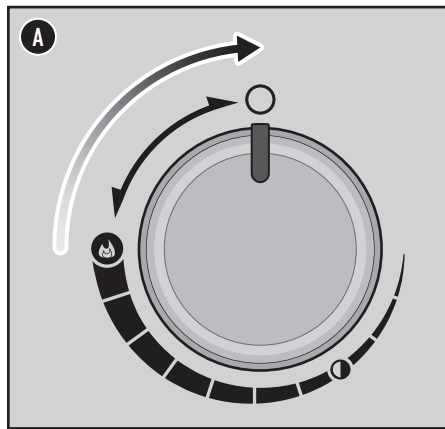

⚠ DANGER: Do not use a flame to check for gas leaks. Be sure there are no sparks or open flames in the area while you check for leaks.

⚠ DANGER: Leaking gas may cause a fire or explosion.

⚠ DANGER: Do not operate the barbecue if there is a gas leak present.

⚠ DANGER: If you see, smell, or hear the hiss of gas escaping from the LPG cylinder:

1. Move away from LPG cylinder.
2. Do not attempt to correct the problem yourself.
3. Call the emergency fire services.

⚠ DANGER: Always close the cylinder valve before disconnecting the regulator. Do not attempt to disconnect the gas regulator and hose assembly or any gas fitting while this barbecue is in operation.

⚠ DANGER: Do not store a spare LPG cylinder under or near this barbecue. Never fill the cylinder beyond 80% full. Failure to follow these statements exactly may result in a fire causing death or serious injury.

What is a Leak Check?

Once the LPG cylinder is properly installed, it is necessary to perform a leak check. A leak check is a reliable way to verify that gas is not escaping after you connect the cylinder. The following fittings should be tested each time a cylinder is refilled and reinstalled:

- Where the regulator connects to the cylinder.
- Where the gas hose connects to the bulkhead.
- Where the bulkhead connects to the corrugated gas line.

Checking for Gas Leaks

- 2) Slowly open gas supply by turning cylinder valve anti-clockwise while checking for bubbles.
- 3) If bubbles appear there is a leak:
 - a) If the leak is at the regulator-to-cylinder connection **(C)** or the regulator hose-to-regulator connection **(D)**, turn gas supply off. **DO NOT OPERATE THE BARBECUE.** Contact the Customer Service Representative in your area using the contact information on our website.

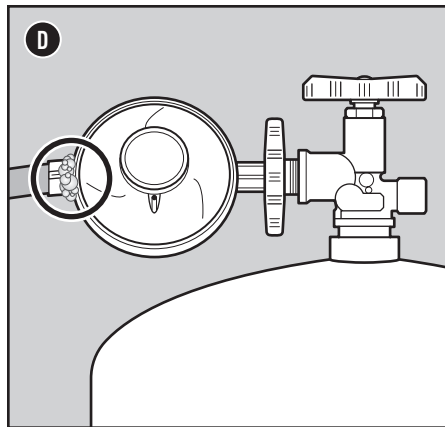
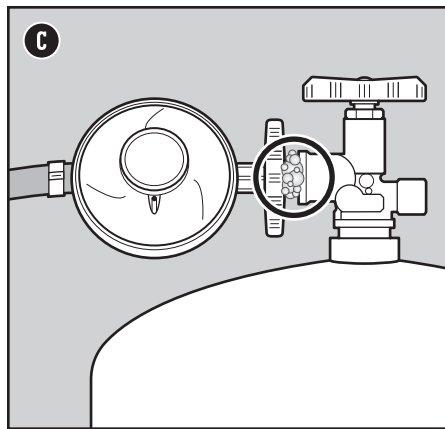

⚠ **DANGER:** Do not use a flame to check for gas leaks. Be sure there are no sparks or open flames in the area while you check for leaks.

⚠ **DANGER:** Leaking gas may cause a fire or explosion.

⚠ **DANGER:** Do not operate the barbecue if there is a gas leak present.

⚠ **DANGER:** If you see, smell, or hear the hiss of gas escaping from the LPG cylinder:

1. Move away from LPG cylinder.
2. Do not attempt to correct the problem yourself.
3. Call the emergency fire services.

⚠ **DANGER:** Always close the cylinder valve before disconnecting the regulator. Do not attempt to disconnect the gas regulator and hose assembly or any gas fitting while this barbecue is in operation.

⚠ **DANGER:** Do not store a spare LPG cylinder under or near this barbecue. Never fill the cylinder beyond 80% full. Failure to follow these statements exactly may result in a fire causing death or serious injury.

- b) If the leak is at any fittings indicated in illustration (E), re-tighten fitting with a wrench and recheck for leaks with soap and water solution. If leak persists, turn off the gas. DO NOT OPERATE THE BARBECUE.
- c) If the leak is at any fittings indicated in illustration (F), turn off the gas. DO NOT OPERATE THE BARBECUE.

If a leak is present, contact the Customer Service Representative in your area using the contact information on our website.

NOTE: Since some leak test solutions, including soap and water, may be slightly corrosive, all connections should be rinsed with water after checking for leaks.

Additional Leak Check Precautions

The following fittings should be tested for gas leaks each time a tank is refilled and reinstalled:

- At the regulator and where the regulator connects to the cylinder (C).

Follow the instructions for "Checking for Gas Leaks".

Disconnect the Regulator from the Cylinder

To remove a cylinder:

- 1) Confirm that the LPG cylinder valve or regulator lever are fully closed.
- 2) From inside cabinet release the clasp on the cylinder retention strap.
- 3) Disconnect the regulator.
- 4) Remove the cylinder.

Use caution if replacing an LP cylinder (tank) during a cooking session. The entire cook box and grease management system gets hot when in use. Always wear heat resistant gloves or Mitts when handling the LP Cylinder (tank). Fasten cylinder strap after connecting new cylinder.

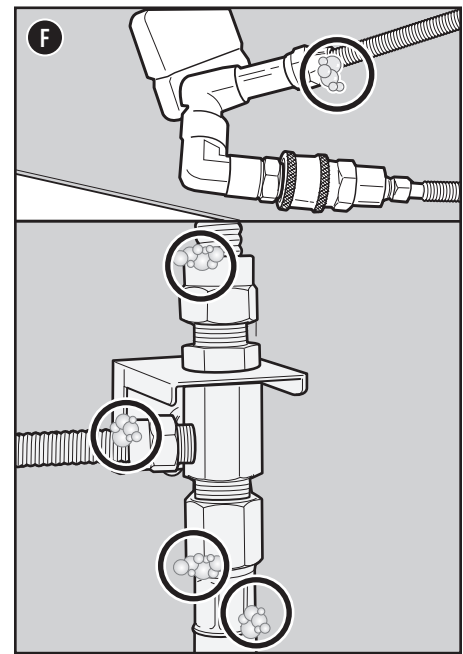
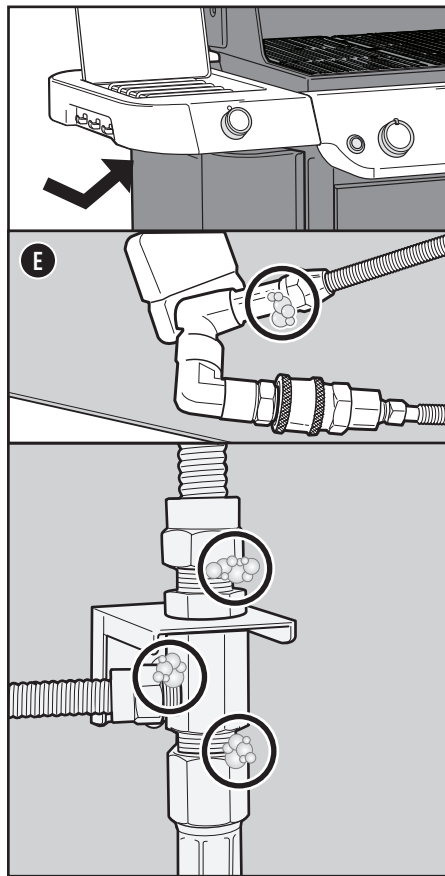

The Very First Time You Barbecue

Perform an Initial Burn-Off

Heat the barbecue on the highest setting, with the lid closed, for at least 20 minutes prior to barbecuing for the first time.

Every Time You Barbecue

Meal-to-Meal Maintenance

The Meal-To-Meal Maintenance plan includes the following simple, yet important, steps that should always be performed prior to barbecuing.

Check for Grease

Your barbecue was built with a grease management system that funnels grease away from food and into a disposable container. As you cook, grease is channelled down the slide-out grease tray and into a disposable drip tray that lines the catch pan. This system should be cleaned each and every time you barbecue to prevent fires.

1. Confirm that the barbecue is off and cool.
2. Open the doors.
3. Access the slide-out grease tray by pulling the tray towards you until it stops (A). Remove excess grease with a plastic scraper. Scrape the grease down through the opening in the grease tray, into the catch pan below.
4. Remove the catch pan (B). Check for excessive amounts of grease in the disposable drip pan that lines the catch pan. Discard disposable drip pan when necessary and replace with a new one.
5. Reinstall all components.

Inspect the Hose

Routine inspection of the hose is necessary.

1. Confirm that the barbecue is off and cool.
2. Check hose for any signs of cracking, abrasions, or cuts (C). If the hose is found to be damaged in any way, do not use the barbecue.

Preheat the Barbecue

Preheating the barbecue is critical to successful barbecuing. Preheating helps to prevent food from sticking to the grate and gets the grate hot enough to sear properly. It also burns off any residue from the previous meal.

1. Open the barbecue lid.
2. Ignite your barbecue according to the ignition instructions in this Owner's Manual.
3. Close lid.
4. Preheat the barbecue with all burners on the start/high position for 15 minutes (D).

Clean the Cooking Grate

After preheating, any bits of food or debris left over from previous use will be easier to remove. Cleaned grates will also prevent your next meal from sticking.

1. Brush the grates with a stainless steel bristle barbecue brush immediately after preheating (E).

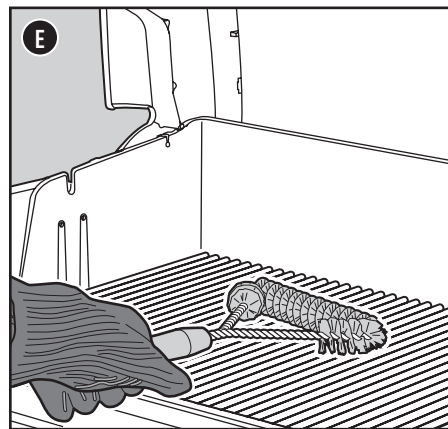
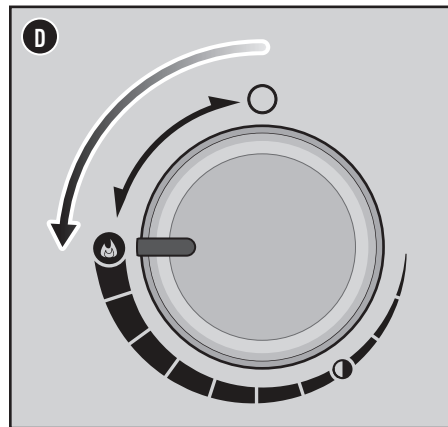
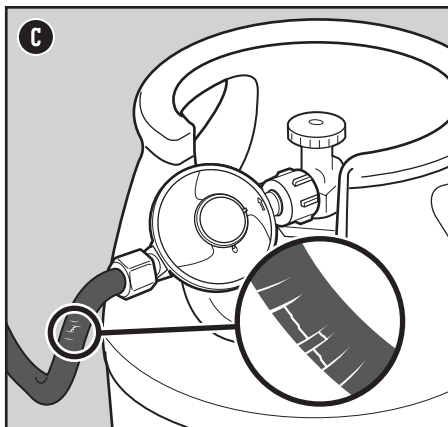
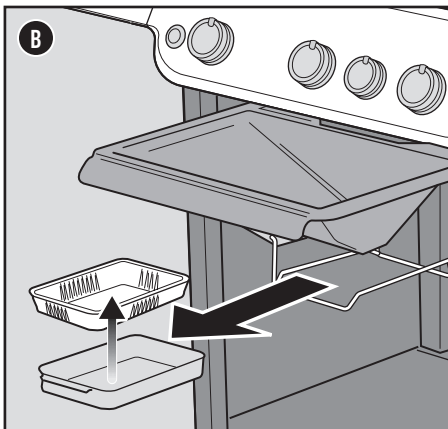
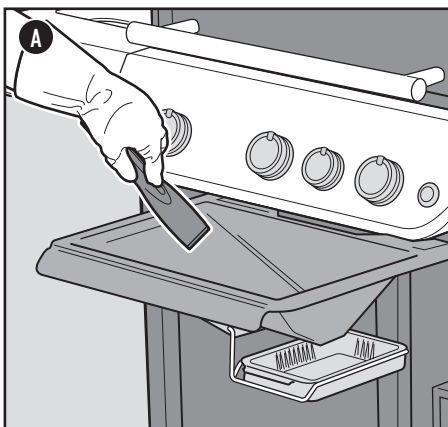

⚠ **DANGER:** Do not line the slide-out grease tray or cookbox with aluminium foil.

⚠ **DANGER:** Check the slide-out grease tray and catch pan for grease build-up before each use. Remove excess grease to avoid a grease fire.

⚠ **WARNING:** Use caution when removing catch pan and disposing of hot grease.

⚠ **WARNING:** Use heat-resistant barbecue mitts or gloves when operating barbecue.

⚠ **WARNING:** Barbecue brushes should be checked for loose bristles and excessive wear on a regular basis. Replace brush if any loose bristles are found on cooking grates or brush. WEBER recommends purchasing a new stainless steel bristle barbecue brush at the beginning of every spring.





⚠ **WARNING:** If the hose is found to be damaged in any way, do not use the barbecue. Replace using only WEBER authorized replacement hose.

⚠ **WARNING:** Keep ventilation openings around tank clear and free of debris.

Igniting the Barbecue

Using the Electronic Ignition System to Ignite the Barbecue

Each control knob operates an individual burner, and each burner ignites independently. Ignite the burners starting from left to right. All burners should be lit for preheating, however, all burners do not have to be lit while barbecuing.

- 1) Open the barbecue lid (A).
- 2) Check that all burner control knobs are in the off  position. Check by pushing in and turning knobs clockwise (B).
Note: It is important that all burner control knobs are in the off  position before turning on the LPG cylinder.
- 3) Turn gas supply on by turning cylinder valve anti-clockwise.
- 4) Begin with the burner furthest to the left. Push the burner control knob in and turn it anti-clockwise to the start/high  position (C).
- 5) Push and hold the electronic ignition button (D). You will hear it ticking.
- 6) Check that the burner is lit by looking through the cooking grates and through the half-circle cutout in the FLAVORIZER BARS.
- 7) If the burner does not ignite, turn burner control knob to the off  position and wait five minutes to allow the gas to clear before attempting to light the burner again.
- 8) If the burner ignites, repeat steps 4 through 6 to light the remaining burners.

Should the burners fail to ignite using the electronic ignition, refer to the TROUBLESHOOTING section. There you will find instructions on igniting the barbecue with a match to help determine the exact problem.

To Extinguish Burners

- 1) Push each burner control knob in and then turn clockwise all the way to the off  position.
- 2) Turn gas supply off at the LPG cylinder.

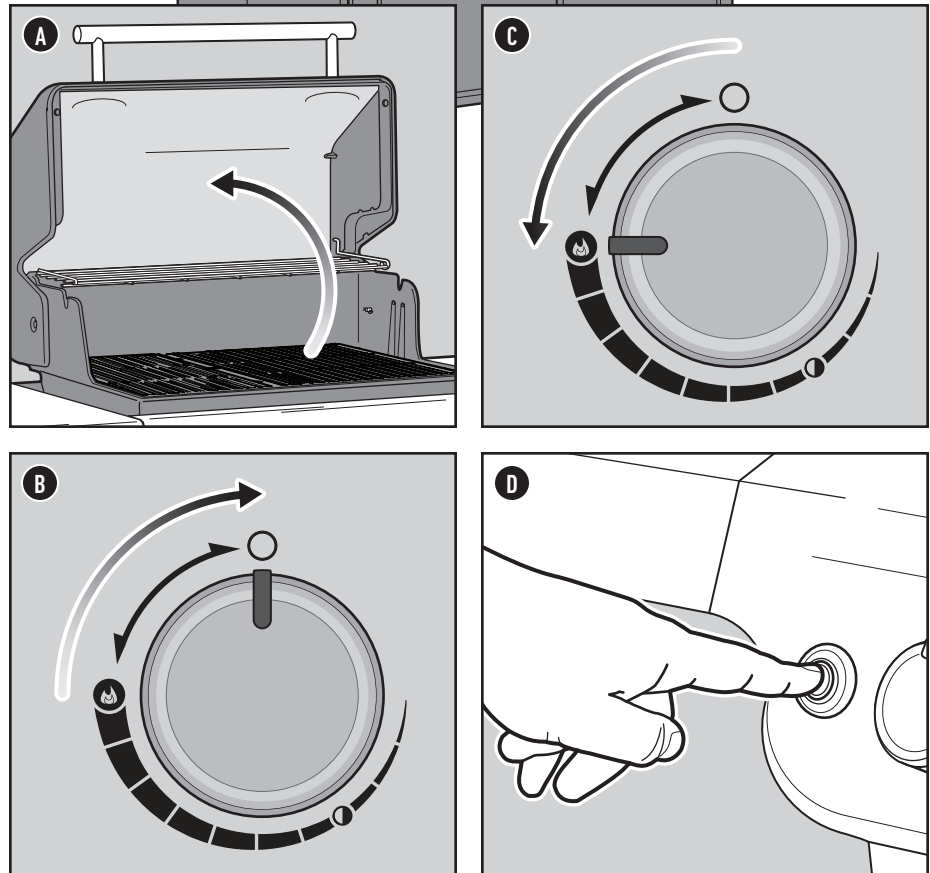



- ⚠ WARNING: Open lid during ignition.
- ⚠ WARNING: Do not lean over open barbecue while igniting or cooking.
- ⚠ WARNING: Each burner must be ignited individually by pushing the electronic ignition button.
- ⚠ WARNING: If ignition does not occur within four seconds of attempting to light the first burner, turn the burner control knob to the off position. Wait five minutes to allow accumulated gas to dissipate, and then repeat the lighting procedure.

Using the Sear Zone

Searing is a direct barbecuing technique used on meats, such as steak, poultry parts, fish and chops. Searing browns the surface of the food at a high temperature. By searing both sides of the meat, you caramelize the food surface, creating a more desirable flavour.

Ignition of the sear burner is the same as ignition of a main burner, each burner ignites independently.

- 1) Open the lid and ignite all of the burners including the sear burner. Refer to USING THE ELECTRONIC IGNITION SYSTEM TO IGNITE THE BARBECUE.
- 2) Preheat the barbecue with the lid closed and with all burners on the start/high  position for 15 minutes.
- 3) After preheating, leave the sear burner control knob and the adjacent burner control knobs in the start/high  position **(A)**. The sear burner works in tandem with adjacent burners **(B)**. The remaining burner(s) can be turned to off or low.
- 4) Place meat directly over the sear zone and close lid. Sear each side anywhere from one to four minutes **(C)**, depending on the type and thickness of meat. Once searing is complete, the meat can be moved over to moderate heat and cooked to your desired doneness.

Note: Always cook with the lid closed to achieve maximum heat and to avoid flare-ups.

As you gain experience using the sear zone we encourage you to experiment with different searing times to find the results that work best for your taste.

To Extinguish Burners



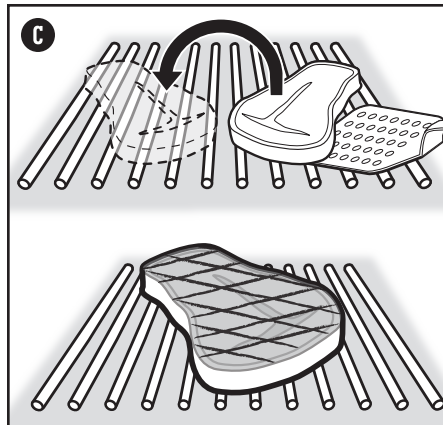
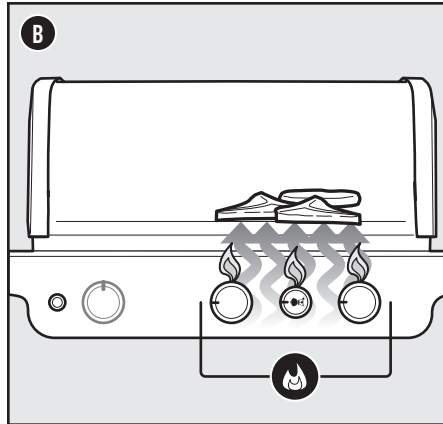
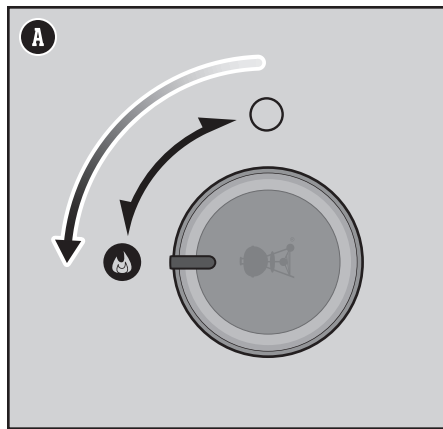

- 1) Push each burner control knob in and then turn clockwise all the way to the off  position.
- 2) Turn gas supply off.



Igniting the Side Burner

Use the Electronic Ignition to Ignite the Side Burner

If one or more of the main burners on your barbecue are already lit and you would like to ignite the side burner, skip to step 3. If none of the main burners are lit and you are only using the side burner, start with step 1.

- 1) Check that the side burner control knob is in the off  position. Check by pushing in and turning the knob clockwise (A). Also check that all main burner control knobs are in the off  position.
Note: It is important that all burner control knobs are in the off  position before turning on the LPG cylinder.
- 2) Turn gas supply on by turning cylinder valve anti-clockwise.
- 3) Open the side burner lid (B).
- 4) Push in and turn the side burner control knob anti-clockwise to start/high  position (C).
- 5) Push and hold in the electronic ignition button (D). You will hear the igniter clicking. Check that the side burner is lit. The side burner flame may be difficult to see on a bright sunny day.
- 6) Once side burner is ignited, continue turning the knob anti-clockwise until you reach the desired position.
- 7) If the side burner does not ignite within 4 seconds, turn side burner control knob to the off  position and wait five minutes to allow the gas to clear before attempting to light the burner again.

Should the side burner fail to ignite using the electronic ignition, refer to the TROUBLESHOOTING section. There you will find instructions on igniting the side burner with a match to help determine the exact problem.

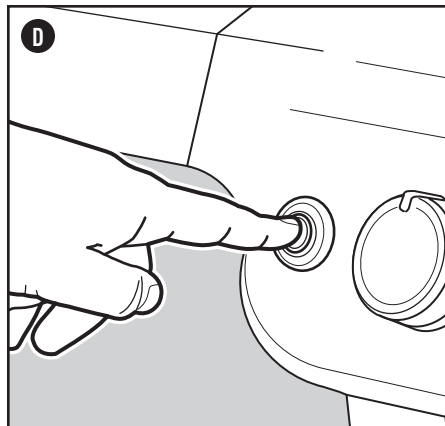
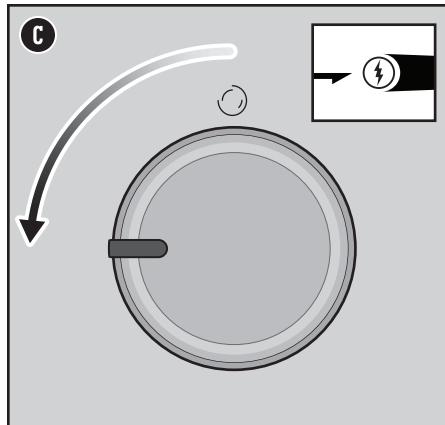
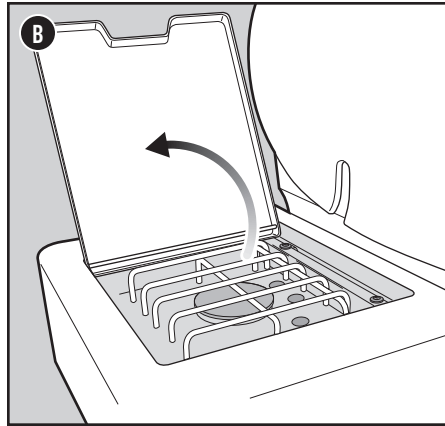
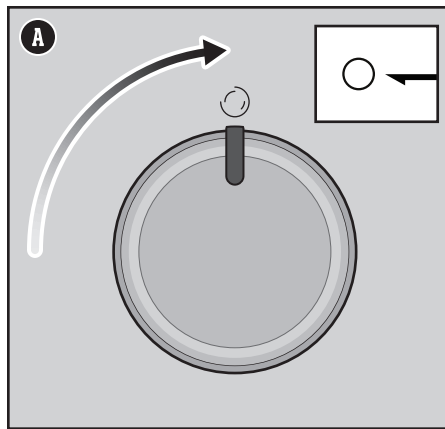

To Extinguish Side Burner

- 1) Push side burner control knob in and then turn clockwise all the way to the off  position.
- 2) Turn gas supply off at the LPG cylinder.

How to Relocate Burner Caps Correctly

See diagram below.

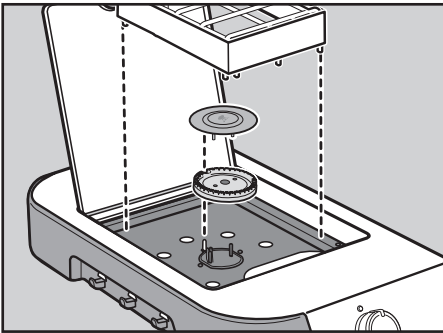

- ⚠ **WARNING:** Open side burner lid during ignition.
- ⚠ **WARNING:** Do not lean over side burner while igniting or cooking.
- ⚠ **WARNING:** If ignition does not occur within four seconds of attempting to light the side burner, turn the burner control knob to the off position. Wait five minutes to allow accumulated gas to dissipate, and then repeat the lighting procedure.

The Flame - Direct or Indirect

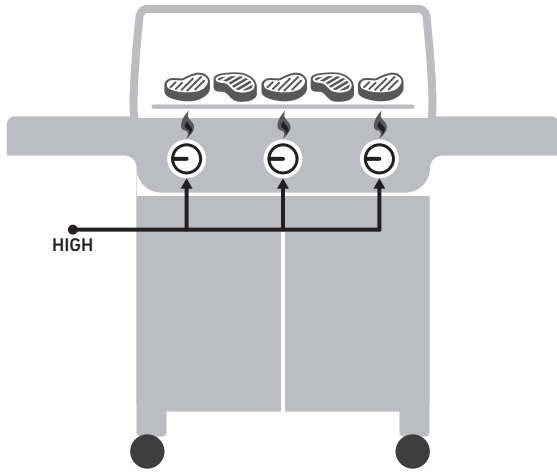

DIRECT HEAT SETUP

Use the direct method for small, tender pieces of food that take less than 20 minutes to cook, such as: hamburgers, steaks, chops, kabobs, boneless chicken pieces, fish fillets, shellfish, and sliced vegetables.

With direct heat, the fire is right below the food. It sears the surfaces of the food, developing flavors, texture, and delicious caramelisation while cooking the food all the way to the centre.

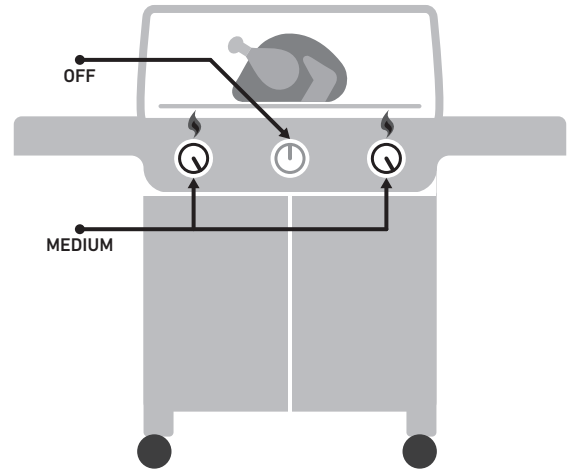

INDIRECT HEAT SETUP

Use the indirect method for larger cuts of meat that require 20 minutes or more of barbecuing time, or for foods so delicate that direct exposure to the heat would dry them out or scorch them, such as: roasts, bone-in poultry pieces, whole fish, delicate fish fillets, whole chickens, turkeys, and ribs. Indirect heat can also be used for finishing thicker foods or bone-in cuts that have been seared or browned first over direct heat.

With indirect heat, the heat is on both sides of the barbecue, or off to one side of the barbecue. The food sits over the unlit part on the cooking grate.

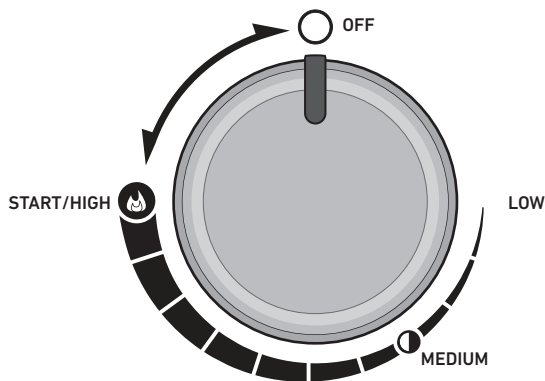

BARBECUE MITTS

When in doubt, wear them. The good ones are insulated and protect both hand and forearm.

MUST-HAVE BARBECUING TOOLS • MUST-HAVE BARBECUING TOOLS • MUST-HAVE BARBECUING TOOLS • MUST-HAVE BARBECUING TOOLS • MUST-HAVE BARBECUING TOOLS

Discover What's Possible

WEBER CRAFTED Outdoor Kitchen Collection Ready

This feature is only available on select models.

Some models are Outdoor Kitchen Collection Ready with the included Grates and Frame. Remove the right-hand cooking grate. Place the Frame on the right-hand side of the cook box for the widest range of heat control **(A)**.

The Spacer included with your barbecue is used only when cooking with the WEBER CRAFTED Outdoor Kitchen Collection **(B)**.

Look for these and other accessories on weber.com.

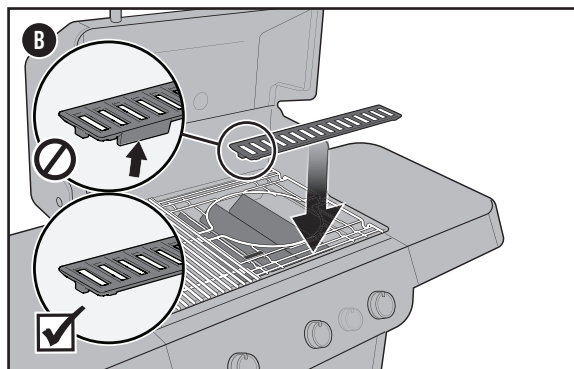
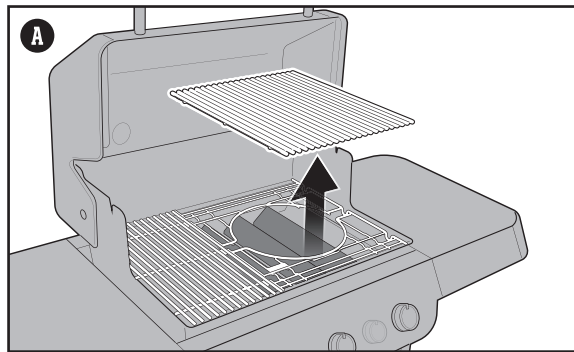

Barbecuing Do's and Don'ts

Preheat each and every time.

If the cooking grates are not hot enough, the food will stick and you will likely never have a chance of searing your food properly or developing those handsome sear marks. Even if a recipe calls for medium or low heat, always preheat the barbecue on the highest setting first. Open the lid, turn up the heat, close the lid, and then let the cooking grate heat up for 15 minutes on high.

Don't barbecue on dirty grates.

Placing food onto the cooking grates before they have been cleaned is never a good idea. Leftover "stuff" on the grates acts like glue, binding it to the grates and your new food. To avoid tasting last night's dinner on today's lunch, make sure that you are barbecuing on a clean cooking grate. Once the grates are preheated, use a stainless steel bristle barbecue brush to make a clean, smooth surface.

Be present in the process.

Before firing up your barbecue, make sure that everything you need is within arm's reach. Don't forget your essential barbecuing tools, such as oiled and seasoned food, glazes or sauces and clean cooking platters for the cooked food. Having to run back to your kitchen not only means missing out on the fun, but it could also result in burning your food. French chefs call this 'mise en place' (meaning, 'put in place'). We call it 'being present'.

Create a little elbow room.

Packing too much food onto the cooking grates restricts your flexibility. Leave at least one-quarter of the cooking grates clear with plenty of space between each food item in order to get your tongs in there and easily move the food around. Sometimes barbecuing involves split-second decisions and the need to move food from one area of the barbecue to another. So give yourself enough room to operate.

Try not to peek.

The lid on your barbecue is for more than just keeping the rain out. Most importantly, it's for preventing too much air from getting in and too much heat and smoke from getting out. When the lid is closed, the cooking grates are hotter, the barbecuing times are faster, the smoky tastes are stronger, and the flare-ups are fewer. So put a lid on your barbecue!

Only flip once.

What's better than a juicy steak with a deep sear and plenty of beautifully-caramelised bits? The key to accomplishing these results is to keep your food in place. Sometimes we have the tendency to flip our food before it reaches the desired level of colour and flavour. In nearly all cases, you should turn food just once. If you are moving it more than that, you are probably also opening the lid too often which causes its own set of problems. So step back and trust the barbecue.

Know when to tame the flame.

When barbecuing, sometimes the most important thing to know is when to stop. The most reliable way to test doneness of your food is to invest in an instant-read thermometer. This slim little gem will help you pinpoint that critical moment when your food is at its best.

Don't be afraid to experiment.

Back in the 1950s, barbecuing meant one thing: meat (and only meat) charred over open flames. The modern day garden chef doesn't need a kitchen in order to prepare a full course meal. Use your barbecue to make char-grilled starters, sides, and even sweets. Register your barbecue to receive special content that will inspire you along the way. We'd love to join you on your barbecuing adventures.

Extra on the Side

WEBER CRAFTED Barbecue Locker

This feature is only available on select models.

The side storage area (A) is ideal for storing accessories and grillware.

Adjustable condiment basket keeps smaller items close at hand.

Always make sure the rubber mat is in place to protect surfaces.

Storage Hooks

Use the double-sided hooks on the side of the cabinet (B) for convenient storage of cooking grates on the outside of the barbecue. Additional hooks on the inside of the cabinet store the WEBER CRAFTED spacer grate, which can be used with WEBER CRAFTED Outdoor Kitchen Collection grillware.

Note: Do not place hot cooking grates on storage hooks.

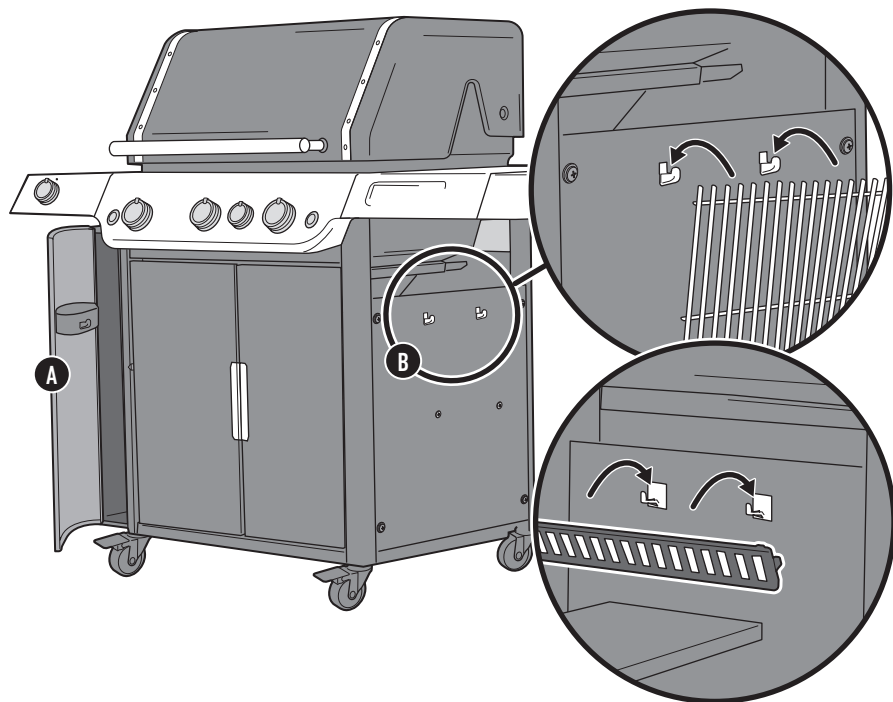

More Cooking Space

Using the Expandable Top Cooking Grate

Use it as a warming rack to keep food warm (A) or unfold it when you need a secondary cooking surface. To unfold, lift the front half of the grate slightly and rotate outward (B). For storage, fold the grate and lift the entire grate from the cook box (C). Hang the grate vertically on the back edge of the cook box. Use heat-resistant mitts or gloves when adjusting rack.

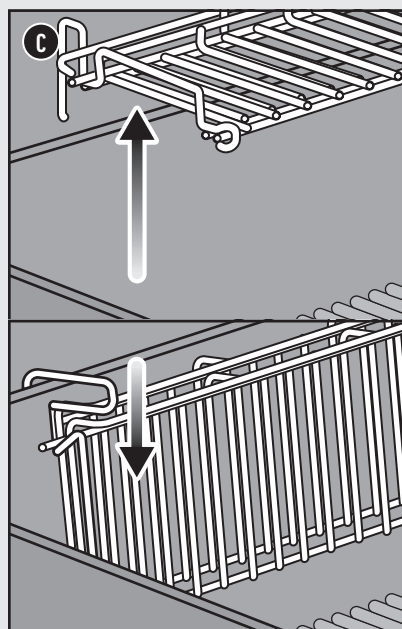
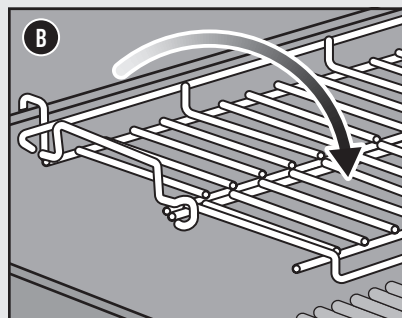
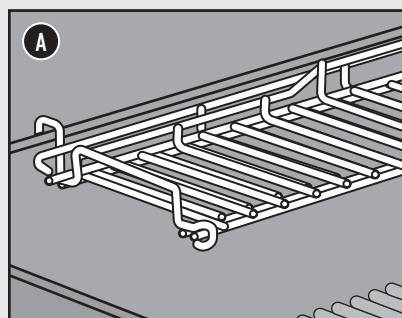

Cleaning and Maintenance

Cleaning the Inside of the Barbecue

Over time, the performance of your barbecue can diminish if it has not been maintained properly. Low temperatures, uneven heat, and food sticking to cooking grates are all signs that cleaning and maintenance are overdue. When your barbecue is off and cool, start by cleaning the inside from the top down. A thorough cleaning is recommended at least twice a year. Consistent use may require quarterly cleanings.

Cleaning the Lid

From time to time you may notice 'paint-like' flakes on the inside of the lid. During use, grease and smoke vapours slowly change into carbon and deposit on the inside of your barbecue's lid. These deposits will eventually peel, and look very similar to paint. These deposits are non-toxic, but the flakes could fall onto your food if you do not clean the lid regularly.

- 1) Brush the carbonised grease from the inside of the lid with a stainless steel bristle barbecue brush (A). To minimise further build-up, the inside of the lid can be wiped with a paper towel after barbecuing while the barbecue is still warm (not hot).

Cleaning the Cooking Grates

If you have been cleaning your cooking grates as recommended, the debris on your grates should be minimal.

- 1) With grates installed, brush the debris off your cooking grate with a stainless steel bristle barbecue brush (B).
- 2) Take the grates out and set aside.

Cleaning the FLAVORIZER BARS

FLAVORIZER BARS catch drippings that smoke and sizzle, adding flavour to your food. Any drippings that are not vapourised by the FLAVORIZER BARS are funnelled away from the burners. This helps prevent flare-ups inside of your barbecue, and protects the burners from getting clogged.

- 1) Scrape the FLAVORIZER BARS with a plastic scraper (C).
- 2) If necessary, brush the FLAVORIZER BARS with a stainless steel bristle barbecue brush.
- 3) Remove FLAVORIZER BARS and set aside.

Cleaning the Burners

Two areas on the burners that are key to optimum performance are the ports (small raised openings running along the length of the burners) and the spider/insect screens on the ends of the burner. Keeping these areas clean is essential for safe operation.

Cleaning the Burner Ports

- 1) Use a clean stainless steel bristle barbecue brush to clean the outside of the burners by brushing across the top of the burner ports (D).
- 2) When cleaning the burners, avoid damaging the ignition electrode by carefully brushing around it (E).

Cleaning the Spider Screens

- 1) Locate the ends of the burners on the underside of the control panel where they meet the valves.
- 2) Clean the spider/insect screens on each of the burners using a soft bristle brush (F).

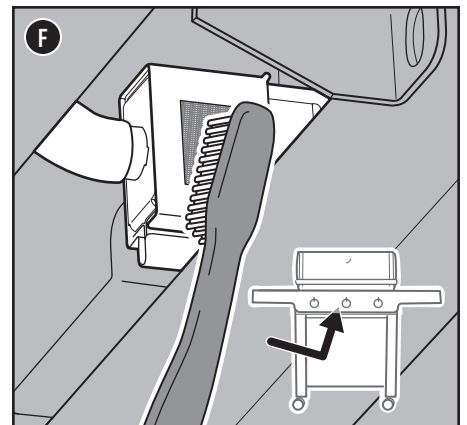
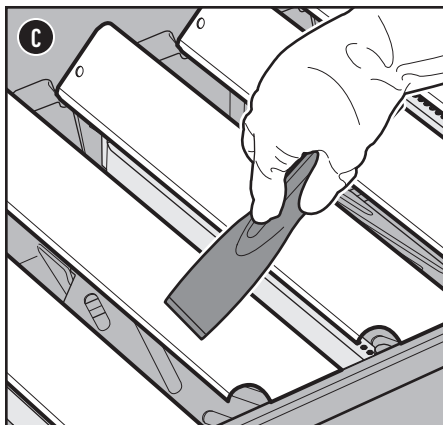
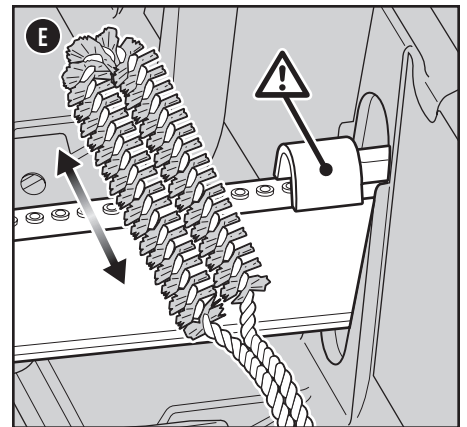
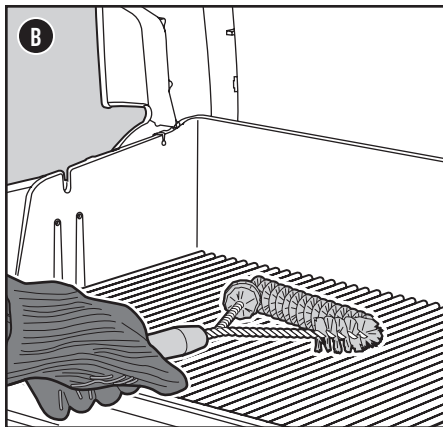
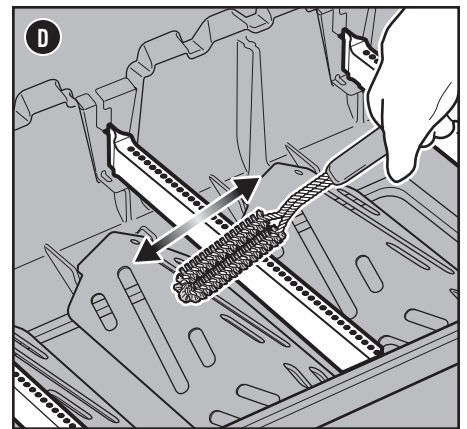
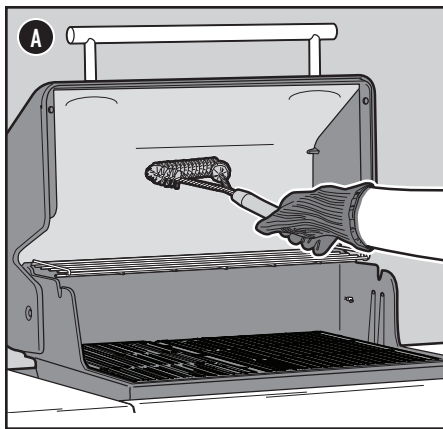

⚠ **WARNING:** Turn your barbecue off and wait for it to cool before thoroughly cleaning it.

⚠ **WARNING:** Over time, the development of rough surfaces can form on the FLAVORIZER BARS. Wearing gloves is recommended when handling. Do not clean FLAVORIZER BARS or cooking grates in a sink, dishwasher, or self-cleaning oven.

⚠ **WARNING:** When cleaning the burners, never use a brush that has already been used to clean the cooking grates. Never put sharp objects into the burner port holes.

⚠ **CAUTION:** Do not place any barbecue components onto the side tables as they may scratch the paint or stainless steel surfaces.

⚠ **CAUTION:** Do not use any of the following to clean your barbecue: abrasive stainless steel polishes or paints, cleaners that contain acid, mineral spirits or xylene, oven cleaner, abrasive cleansers (kitchen cleansers), or abrasive cleaning pads.

Cleaning the Heat Deflectors

Located under the burners, the heat deflectors distribute heat evenly throughout the cookbox while cooking. Keeping heat deflectors clean will enhance the cooking performance of your barbecue.

- 1) Scrape the heat deflectors with a plastic scraper (**G**).
- 2) If necessary, brush the heat deflectors with a stainless steel bristle barbecue brush.
- 3) Remove heat deflectors and set aside.

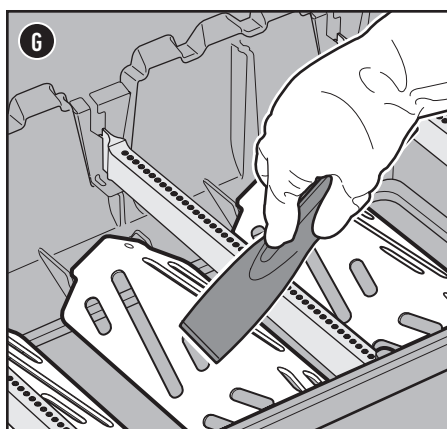

Cleaning the Cookbox

Look inside the cookbox for any grease accumulation or leftover food particles. Excessive accumulation can cause a fire.

- 1) Use a plastic scraper to scrape debris off the sides and bottom of the barbecue into the opening in bottom of the cook box (**H**). This opening leads debris into the slide-out grease tray.

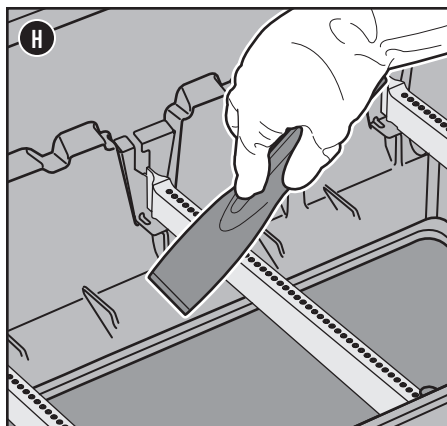

Cleaning the Grease Management System

The grease management system consists of an angled slide-out grease tray and a catch pan. These components were designed to be easily removed, cleaned, and replaced; an essential step every time you prepare to barbecue. Instructions on inspecting the grease management system can be found in MEAL-TO-MEAL MAINTENANCE.

Cleaning the Outside of the Barbecue

The outside of your barbecue may include stainless steel, porcelain-enamelled, and plastic surfaces. WEBER recommends the following methods based on the surface type.

Cleaning Stainless Steel Surfaces

Clean stainless steel using a non-toxic, non-abrasive stainless steel cleaner or polish designed for use on outdoor products and barbecues. Use a microfibre cloth to clean in the direction of the grain of the stainless steel. Do not use paper towels.

Note: Do not risk scratching your stainless steel with abrasive pastes. Pastes do not clean or polish. They will change the colour of the metal by removing the top chromium oxide film coating.

Cleaning Painted, Porcelain-Enamelled Surfaces and Plastic Components

Clean painted, porcelain-enamelled and plastic components with warm soapy water, and paper towels or cloth. After wiping down the surfaces, rinse and dry thoroughly.

Cleaning the Outside of Barbecues that are in Unique Environments

If your barbecue is subject to a particularly harsh environment, you will want to clean the outside more often. Acid rain, pool chemicals, and salt water can cause surface rusting to appear. Wipe down the outside of your barbecue with warm soapy water. Follow up with a rinse and thorough drying. Additionally, you may want to apply a stainless steel cleaner weekly to prevent surface rust.

FOIL PANS
Perfect for lining the catch pan to make cleanup convenient and easy.

BARBECUE BRUSH
A must-use before you even dream of barbecuing. A quick once-over on hot grates prevents the charred remains of meals past from sticking to your meals present.

MAIN BURNER(S) or SIDE BURNER WILL NOT IGNITE

SYMPTOM

- Main burners or side burner do(es) not ignite when following the electronic ignition instructions in the “Operation” section of this owner's manual.

CAUSE

There is a problem with gas flow.

SOLUTION

If any burner does not ignite, the first step is to determine if there is gas flowing to the burner(s). To check this, follow the instructions below for “Lighting Your Barbecue with a Long-Reach Lighter.”

If **match lighting IS NOT successful**, follow the “GAS FLOW” troubleshooting suggestions on the next page.

There is a problem with the electronic ignition system.

If any burner does not ignite, the first step is to determine if there is gas flowing to the burner(s). To check this, follow the instructions below for “Lighting Your Barbecue with a Long-Reach Lighter.”

If **match lighting IS successful**, follow the instructions for “Checking the Components of the Electronic Ignition System.”

Lighting Your Barbecue with a Long-Reach Lighter

Using a Long-Reach Lighter or Long Match to Determine if there is Gas Flow to the Main Burners

- 1) Open the barbecue lid.
- 2) Check that all burner control knobs (including side burner control knob) are in the off \bigcirc position. Check by pushing in and turning knobs clockwise. *Note: It is important that all burner control knobs are in the off \bigcirc position before turning on the LPG cylinder.*
- 3) Turn gas supply on by turning cylinder valve anti-clockwise or by moving regulator lever to the on position depending on your regulator/cylinder connection.
- 4) Begin with the burner furthest to the left. Insert a lit long-reach lighter down through the cooking grates, past the FLAVORIZER BARS and next to the burner (A).
- 5) Push the burner control knob in and slowly turn it anti-clockwise toward the start/high \bullet position.
- 6) Check that the burner is lit by looking through the cooking grates and through the cutout in the FLAVORIZER bar.
- 7) If the burner does not ignite within 4 seconds, turn burner control knob to the off \bigcirc position and wait five minutes to allow the gas to clear before attempting to light the burner again. If repeated attempts fail, follow the gas flow troubleshooting instructions on the next page.
- 8) If the burner ignites, the problem lies in the ignition system. Follow the instructions for “Checking the Components of the Electronic Ignition System”.

Using a Long-Reach Lighter or Long Match to Determine if there is Gas Flow to the Side Burner

- 1) Open the side burner lid.
- 2) Check that all burner control knobs (including side burner control knob) are in the off \bigcirc position. Check by pushing in and turning knobs clockwise. *Note: It is important that all burner control knobs are in the off \bigcirc position before turning on the LPG cylinder.*
- 3) Turn gas supply on by turning cylinder valve anti-clockwise or by moving regulator lever to the on position depending on your regulator/cylinder connection.
- 4) Hold a lit long-reach lighter by the side burner (B).
- 5) Push the side burner control knob in and slowly turn it anti-clockwise toward the start/high \bullet position.
- 6) Check that the side burner is lit. The side burner flame may be difficult to see on a bright sunny day.
- 7) If the side burner does not ignite within 4 seconds, turn side burner control knob to the off \bigcirc position and wait five minutes to allow the gas to clear before attempting to light the burner again. If repeated attempts fail, follow the gas flow troubleshooting instructions on the next page.
- 8) If the burner ignites, follow the instructions for “Checking the Components of the Electronic Ignition System”.

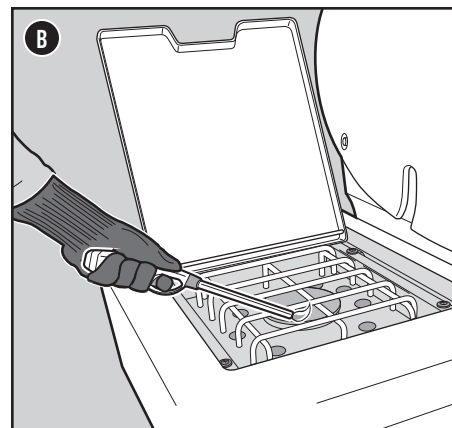
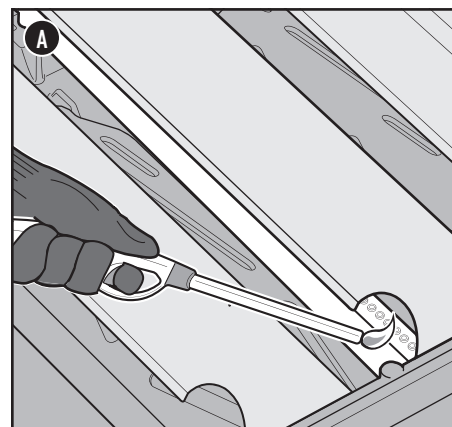
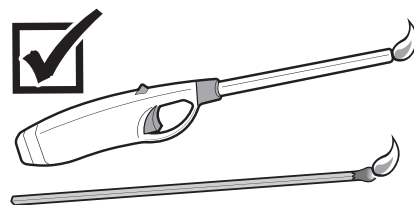

REPLACEMENT PARTS

To obtain replacement parts, contact the local retailer in your area or log onto weber.com.

GAS FLOW

SYMPTOM

- Grill does not reach desired temperature or heats unevenly.
- One or more of the burners fail to ignite.
- Flame is low when burner is on high position.
- Flames do not run the whole length of the burner.
- Burner flame pattern is erratic.
- Burner has a flashback (when the flame burns back to the valve orifice).

CAUSE

SOLUTION

Some countries have regulators with a "flow limiting device" that has been activated. This safety feature built into the regulator restricts the gas flow in the event of a gas leak. You can inadvertently activate this safety feature without having a gas leak. This typically occurs when you turn on the gas at the LPG cylinder and one or more of the control knobs are not in the off position. It may also occur if you turn on the LPG cylinder too quickly.

Reset the "flow limiting device" by closing the LPG cylinder valve and turning all the burner control knobs to the off O position. Wait five minutes to allow accumulated gas to dissipate, then ignite the grill again following the instructions in the "Operation" section.

The LPG cylinder is low or empty.

Refill LPG cylinder.

Fuel hose is bent or kinked.

Straighten fuel hose.

Burner ports are dirty.

Clean burner ports. Refer to "Cleaning the Burner Ports."

SYMPTOM

- Gas is smelled in conjunction with burner flames that appear yellow and lazy.

CAUSE

SOLUTION

Spider screens on the burners are obstructed.

Clean spider screens. Refer to "Cleaning the Spider Screens" in the Product Care section. Also refer to the illustrations and information in this section about proper flame pattern and spider screens.

SYMPTOM

- The smell of gas and/or a light hissing sound.

CAUSE

SOLUTION

The internal rubber seal in the LPG cylinder valve could be damaged.

Inspect the rubber seal for damage. If damaged, return LPG cylinder to local retailer.

Proper Burner Flame Pattern

The burners in your barbecue were factory set for the correct air and gas mixture. When the burners are performing correctly, you will see a specific flame pattern. The tips may occasionally flicker yellow (A), with a descending light blue (B) to dark blue flame (C).

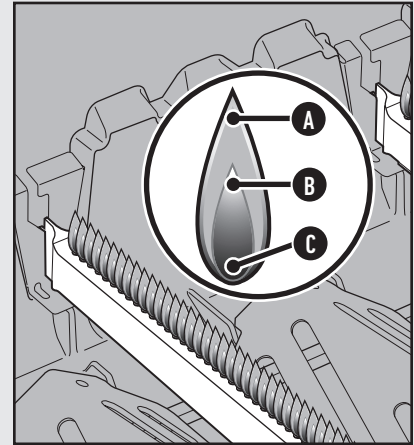

Spider Screens

The combustion air openings of the burners (D) are fitted with stainless steel screens to prevent spiders and other insects from spinning webs and building nests inside the burners. Dust and debris can accumulate on the outside of the spider/insect screen and obstruct the oxygen flow to the burners.

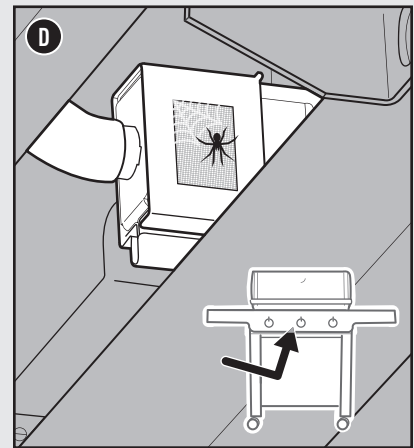

⚠ **WARNING:** Do not attempt to make any repair to gas carrying, gas burning, ignition components or structural components without contacting Weber-Stephen Products LLC, Customer Service Department.

⚠ **WARNING:** Failure to use genuine Weber-Stephen parts for any repair or replacement will void all warranty protection.

⚠ **CAUTION:** The burner tube openings must be positioned properly over the valve orifices.

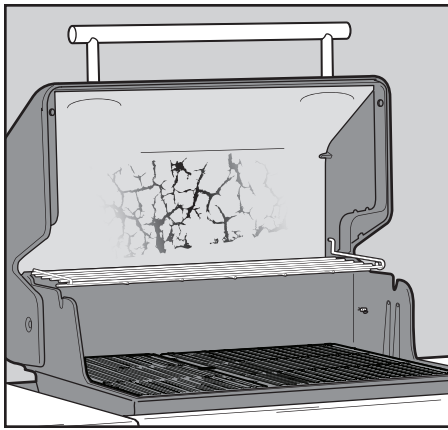

GREASY BARBECUE (Peeling Paint & Flare-Ups)

SYMPTOM

- Inside of lid appears to have the appearance of peeling paint.

CAUSE

The flakes you see are accumulated cooking vapours that have turned into carbon.

SOLUTION

This happens over time after repeated use of your barbecue. This is not a defect. Clean the lid. Refer to the "Product Care" section.

SYMPTOM

- Experiencing flare-ups when barbecuing or preheating.

CAUSE

There is leftover food from the previous meal.

The inside of the barbecue needs to be cleaned thoroughly.

SOLUTION

Always preheat the barbecue on the highest setting for 10 to 15 minutes.

Follow the steps in the "Cleaning and Maintenance" section to clean the barbecue inside from the top down.

CALL CUSTOMER SERVICE

If you are still experiencing any problems, contact the Customer Service Representative in your area using the contact information on weber.com.

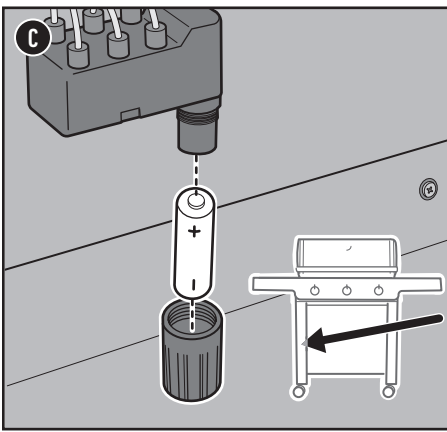

Checking the Components of the Electronic Ignition System

When pressing the ignition button you should hear a ticking sound. If you cannot hear the ticking sound, check the battery, then check the wires. Remove the heat shield to check these components.

Checking the Battery

There are three potential issues with the battery that supplies the power to your ignition module that need to be checked:

- 1) Some batteries have a plastic protective wrap around them. (Do not confuse this plastic with the battery label.) Check that this plastic wrap is removed.
- 2) Confirm that the battery is installed correctly (C).
- 3) If the battery is old, replace it with a new battery.

Checking the Wires

There are two potential trouble spots that need to be checked:

- 1) Check that the ignition wires are connected securely to the terminals on the ignition button under the control panel.
- 2) Make sure the ignition wires are properly attached to the ignition module. The wire terminals are colour coded to correspond with the terminals on the ignition module. The number of wires will vary per model.

NOTE: Reinstall the heat shield to the ignition module.

335 Igniter Module Wire Chart

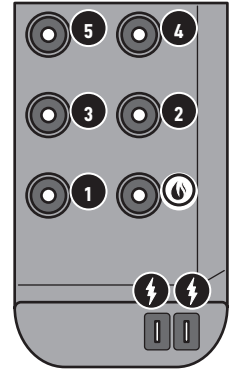
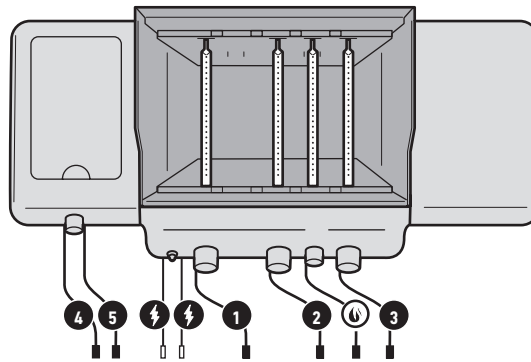

Checking the Ground Wire

Models 425s and 435 have a ground wire connected to the manifold bracket. This is visible from beneath the control panel (D):



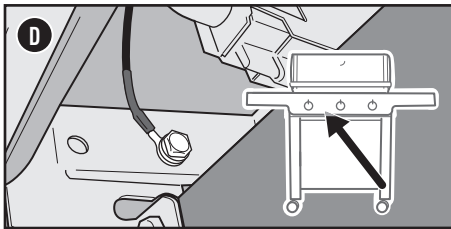

- 1) Check that the ground wire is properly secured with a screw.

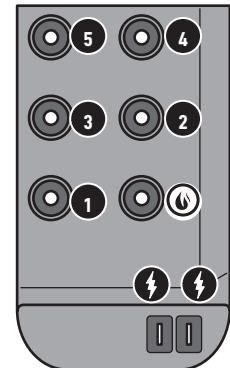
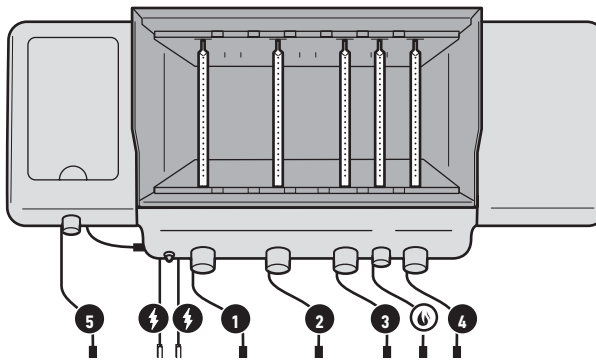

435 Igniter Module Wire Chart



Barbecuing Guide

Type	Thickness/Weight	Approximate Total Barbecue Time
 RED MEAT		
Steak: Sirloin strip, Porterhouse, rib-eye, T-bone, and beef fillet steak (tenderloin)	¾ inch (19 mm) thick 1 inch (25 mm) thick 2 inches (5 cm) thick	4 to 6 minutes direct high heat 6 to 8 minutes direct high heat 14 to 18 minutes sear 6 to 8 minutes direct high heat, then 8 to 10 minutes indirect high heat
Flank Steak	1½ to 2 pounds (0.68 - 0.91 kg), ¾ inch (19 mm) thick	8 to 10 minutes direct medium heat
Minced Beef Patty	¾ inch (19 mm) thick	8 to 10 minutes direct medium heat
Whole beef fillet	3 to 4 pounds (1.36 - 1.81 kg)	45 to 60 minutes 15 minutes direct medium heat, then 30 to 45 minutes indirect medium heat
 PORK		
Bratwurst: fresh	3 ounce (85 g) link ¾ inch (19 mm) thick	20 to 25 minutes direct low heat 6 to 8 minutes direct high heat
Chop: boneless or bone in	1¼ to 1½ inches (3.18 - 3.81 cm) thick	10 to 12 minutes sear 6 minutes direct high heat, then 4 to 6 minutes indirect high heat
Ribs: baby back, spareribs	3 to 4 pounds (1.36 - 1.81 kg)	1½ to 2 hours indirect medium heat
Ribs: country-style, bone in	3 to 4 pounds (1.36 - 1.81 kg)	1½ to 2 hours indirect medium heat
Whole beef fillet	1 pound (0.45 kg)	30 minutes sear 5 minutes direct high heat, then 25 minutes indirect medium heat
 POULTRY		
Chicken Breast: boneless, skinless	6 to 8 ounces (170-226 g)	8 to 12 minutes direct medium heat
Chicken Thigh: boneless, skinless	4 ounces (113g)	8 to 10 minutes direct medium heat
Chicken Pieces: bone in, assorted	3 to 6 ounces (85-170 g)	36 to 40 minutes 6 to 10 minutes direct low heat, then 30 minutes indirect medium heat
Chicken, Whole	4 to 5 pounds (1.81-2.27 kg)	1 to 1¼ hours indirect medium heat
Cornish Game Hen	1½ to 2 pounds (0.68-0.91 kg)	60 to 70 minutes indirect medium heat
Turkey: whole, unstuffed	10 to 12 pounds (4.54-5.44 kg)	2 to 2½ hours indirect medium heat
 SEAFOOD		
Fish, Fillet, or Steak: halibut, red snapper, salmon, sea bass, swordfish, and tuna	¾ to ½ inch (6.35-12.7 mm) thick 1 to 1¼ inches (25-31 mm) thick	3 to 5 minutes direct medium heat 10 to 12 minutes direct medium heat
Fish, whole	1 pound (0.45 kg) 3 pounds (1.36 kg)	15 to 20 minutes indirect medium heat 30 to 45 minutes indirect medium heat
Prawn	1½ ounces (42.5 g)	2 to 4 minutes direct high heat
 VEGETABLES		
Asparagus	½ inch (12.7 mm) diameter in husk	6 to 8 minutes direct medium heat 25 to 30 minutes direct medium heat
Corn	husked	10 to 15 minutes direct medium heat
Mushrooms	shiitake or button portobello	8 to 10 minutes direct medium heat 10 to 15 minutes direct medium heat
Onion	halved ½ inch (12.7 mm) slices	35 to 40 minutes indirect medium heat 8 to 12 minutes direct medium heat
Potatoes	whole ½ inch (12.7 mm) slices	45 to 60 minutes indirect medium heat 9 to 11 minutes parboil 3 minutes, then 6 to 8 minutes direct medium heat

The cuts, thicknesses, weights, and barbecuing times above are meant to be guidelines. Factors such as altitude, wind and outside temperature can affect cooking times. Two rules of thumb: Barbecue steaks, fish fillets, boneless chicken pieces, and vegetables using the direct method for the time given on the chart (or to the desired doneness), turning food once halfway through barbecuing time. Barbecue roasts, whole poultry, bone-in poultry pieces, whole fish, and thicker cuts using the indirect method for the time given on the chart (or until an instant-read thermometer registers the desired internal temperature). Cooking times for beef and lamb use the USDA's definition of medium doneness unless otherwise noted. Before carving, let roasts, larger cuts of meat, and thick chops and steaks rest for 5 to 10 minutes after cooking. The internal temperature of the meat will rise by 5 to 10 degrees during this time.

GENESIS E-335

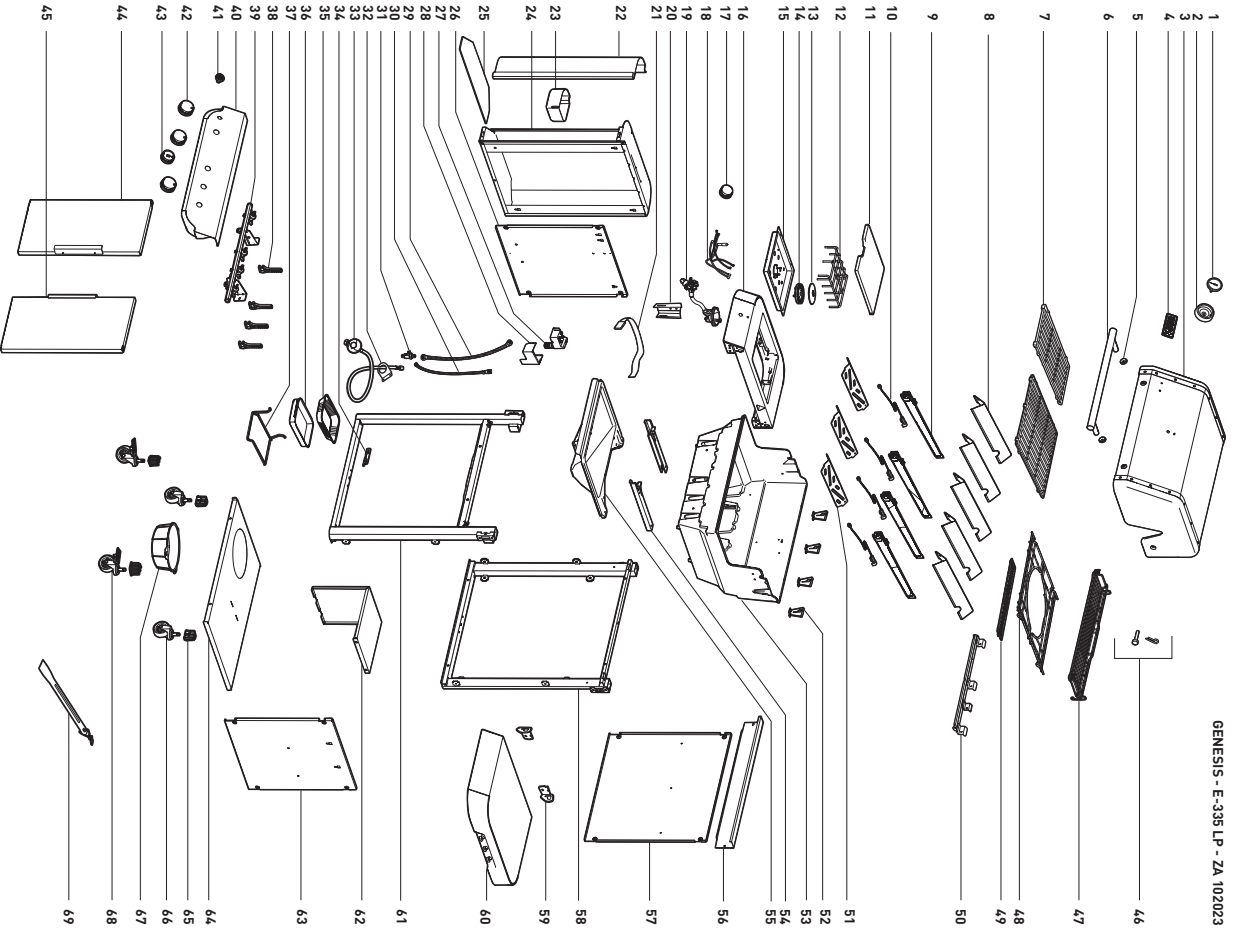

GENESIS E-435

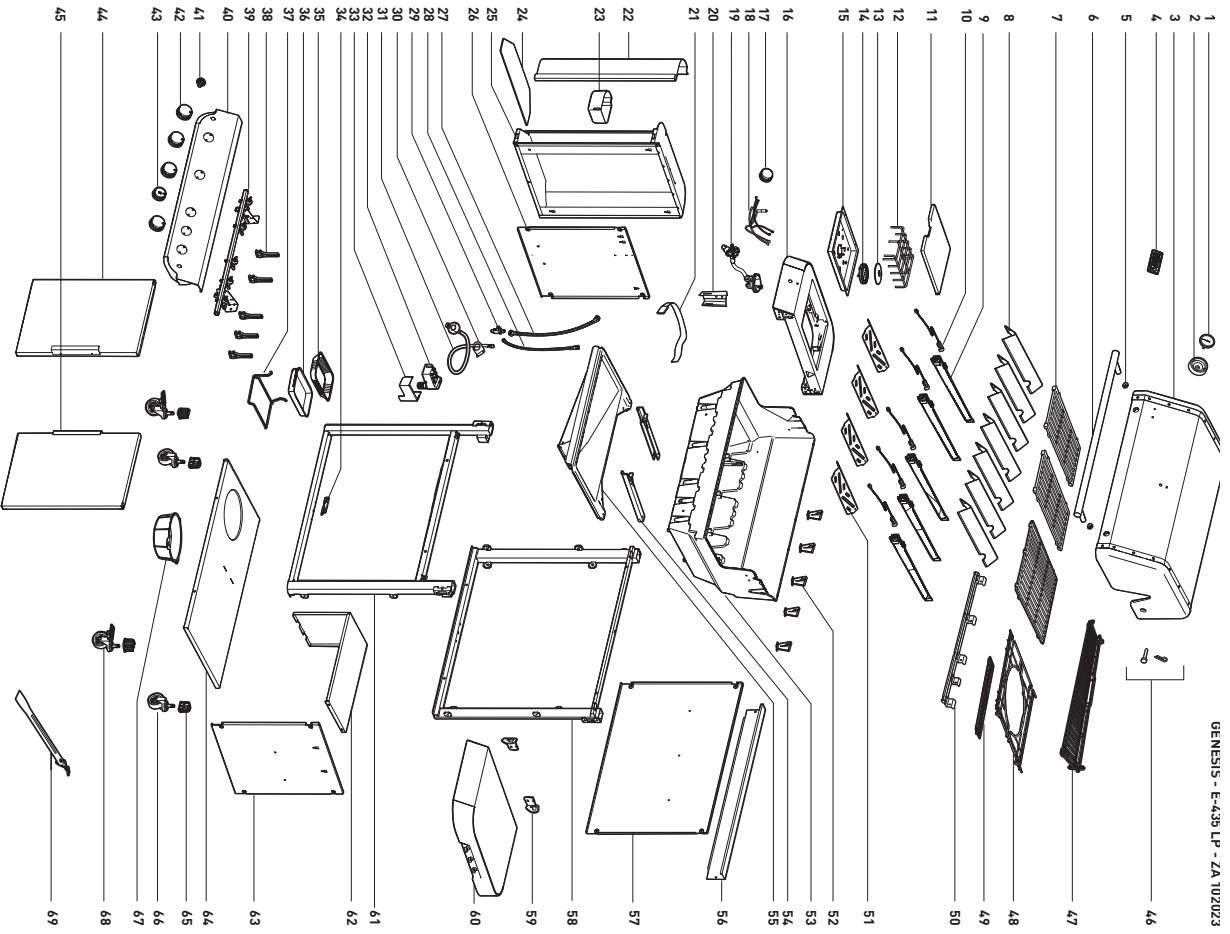



Serial Number

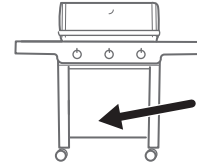

Write your barbecue's serial number in the above box for future reference. The serial number is on the data label located on the inside of the cabinet.

Weber-Stephen Products (South Africa) (Pty) Ltd.

141-142 Hertz Draai
Meadowdale, Edenvale
Gauteng
SOUTH AFRICA

+27 11 454 2369 | info@weber.co.za | weber.com

