



SmokeFire

Wood Pellet Grill STEALTH Edition



MONTAGE-INSTRUCTIES
MONTAGEANLEITUNG
ENSEMBLE GUIDE
GUIDA ALL'ASSEMBLAGGIO

Before you begin



Enhance your assembly experience.

Download the free BILT™ app for
3D step-by-step instructions.



Gratis download | Kostenloser download
Téléchargement gratuit | Download gratuito

63689
10/28/21
NL/DE/FR/IT

NL

- ⚠ Er zijn twee personen nodig voor de montage.
 - ⚠ Volg de montagehandleiding voor specifieke uitpak- en montage-instructies voordat je de barbecue uitpakt.
 - ⚠ Monteer de barbecue op een vlakke, horizontale en zachte ondergrond.
 - ⚠ Gebruik geen elektrisch gereedschap voor de montage.
 - ⚠ Houd het deksel altijd gesloten tijdens het monteren of verplaatsen van de barbecue, tenzij anders aangegeven.
 - ⚠ Zorg ervoor dat alle onderdelen zijn gemonteerd en de schroeven volledig zijn aangedraaid voordat je de barbecue in gebruik neemt.
 - ⚠ Verwijder alle verpakkingsmaterialen en beschermfolie voordat je de barbecue in gebruik neemt.
-

DE

- ⚠ Die Montage muss von zwei Personen durchgeführt werden.
 - ⚠ Sieh dir vor dem Auspacken des Grills die Montageanleitung an, um die Hinweise zum Auspacken und zur Montage zu befolgen.
 - ⚠ Den Grill auf einem flachen, ebenen und weichen Untergrund montieren.
 - ⚠ Für die Montage keine Elektrowerkzeuge verwenden.
 - ⚠ Halte den Deckel immer geschlossen, wenn du den Grill zusammenbaust oder bewegst, sofern nicht anders angegeben.
 - ⚠ Stelle sicher, dass alle Teile ordnungsgemäß zusammengebaut und sicher befestigt sind, bevor du den Grill in Betrieb nimmst.
 - ⚠ Vor der Inbetriebnahme des Grills sämtliches Verpackungsmaterial und alle Schutzfolien entfernen.
-

FR

- ⚠ Le montage requiert deux personnes.
 - ⚠ Avant de déballer votre barbecue, suivez les instructions de déballage et d'assemblage de la notice de montage.
 - ⚠ Procédez au montage du barbecue sur une surface plate, droite et souple.
 - ⚠ N'utilisez pas d'outils électriques pour le montage.
 - ⚠ Gardez toujours le couvercle fermé lorsque vous montez ou déplacez le barbecue, sauf indication contraire.
 - ⚠ Assurez-vous que toutes les pièces sont assemblées et que toutes les vis sont serrées avant de mettre le barbecue en marche.
 - ⚠ Retirez tout l'emballage et le film protecteur avant d'allumer votre barbecue.
-

IT

- ⚠ Per l'assemblaggio sono necessarie due persone.
- ⚠ Prima di disimballare il barbecue, seguire la guida all'assemblaggio per istruzioni specifiche sul disimballaggio e l'assemblaggio.
- ⚠ Assemblare il barbecue su una superficie piana, livellata e morbida.
- ⚠ Non utilizzare utensili elettrici per l'assemblaggio.
- ⚠ Tenere sempre chiuso il coperchio durante l'assemblaggio o la movimentazione del barbecue, salvo diversa indicazione.
- ⚠ Prima di utilizzare il barbecue, assicurarsi che tutte le parti siano assemblate e che la minuteria sia serrata.
- ⚠ Rimuovere tutti gli imballaggi e la pellicola protettiva prima di accendere il barbecue.

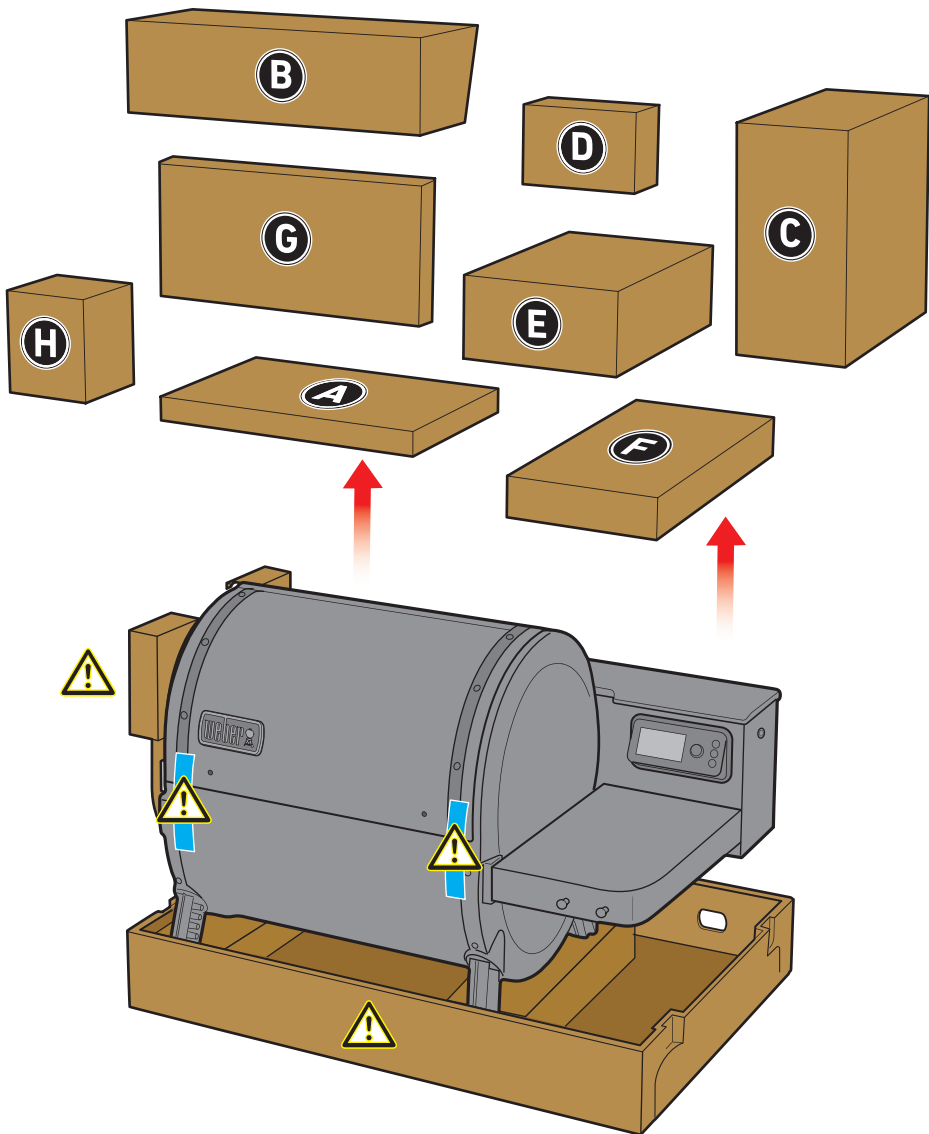

- ⚠ Verwijder de beschermende verpakking onderaan pas als de poten zijn bevestigd.
- ⚠ Verwijder de barbecue niet uit de kartonnen basis.
- ⚠ Verwijder de blauwe tape op het deksel pas wanneer het in de instructies staat.
- ⚠ Das schützende Endpolster erst nach Montage der Beine entfernen.
- ⚠ Grill nicht vom Kartonsockel entfernen.
- ⚠ Entferne das blaue Klebeband auf dem Deckel erst, wenn du dazu aufgefordert wirst.
- ⚠ Ne retirez pas l'embout de protection tant que les pieds ne sont pas montés.
- ⚠ Ne retirez pas le barbecue de la base en carton.
- ⚠ Ne retirez pas le ruban adhésif bleu du couvercle avant d'avoir lu les instructions correspondantes.
- ⚠ Rimuovere la protezione terminale solo dopo aver assemblato le gambe.
- ⚠ Non rimuovere il barbecue dalla base di cartone.
- ⚠ Non rimuovere il nastro blu sul coperchio fino a quando non viene indicato di farlo.

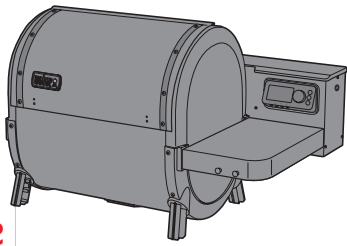

EPX4

EPX6

A

1

1

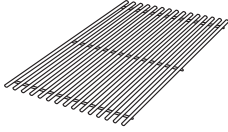

0

1

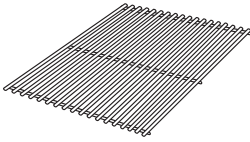

1

1

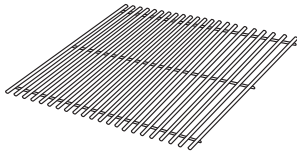

B

1

1

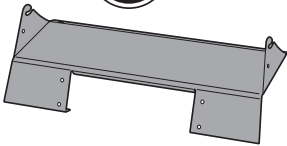

2

2

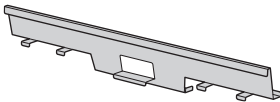

1

1

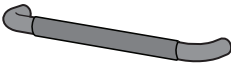

2

2

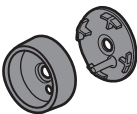

2

2

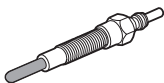

EPX4

EPX6

1

1



1

1



1

1



C

1

1

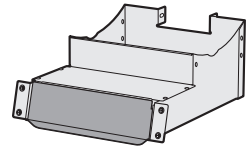

1

1

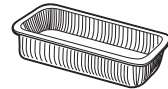

1

1

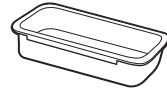

D

2

2



2

2



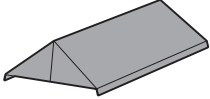
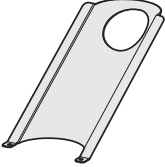
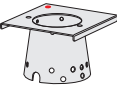
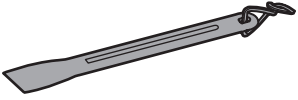

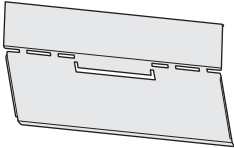
EPX4	EPX6	
4	6	E 
1	1	
1	1	
1	1	
1	1	

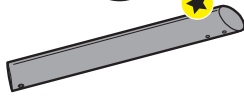
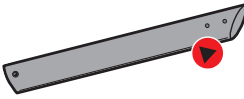
EPX4	EPX6	
1	1	

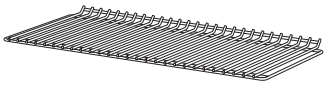
EPX4	EPX6	
2	2	F 
2	2	

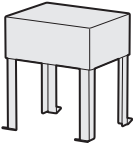
		G
1	1	

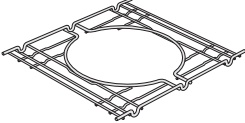
		H
1	1	

		I
1	1	
1	1	

B

18

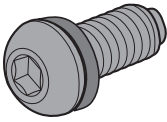

2

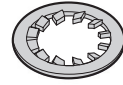

2

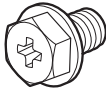

2

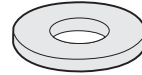

2

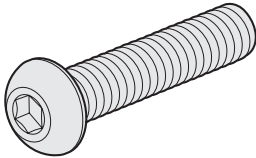

2



**INBEGREPEN GEREEDSCHAPPEN:
ENTHALTENE WERKZEUGE:
OUTILS INCLUS :
ATTREZZI INCLUSI:**

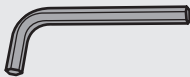

**BENODIGD GEREEDSCHAP:
WERKZEUG ERFORDERLICH:
OUTILS REQUIS :
ATTREZZI NECESSARI:**



1

BILT.

- Download de gratis BILT™-app voor stapsgewijze 3D-instructies.
- Lade die kostenlose BILT™-App herunter, um dir eine Schritt-für-Schritt-Anleitung in 3-D anzeigen zu lassen.
- Téléchargez l'application gratuite BILT™ qui vous expliquera le montage étape par étape en 3D.
- Scaricare l'app BILT™ gratuita per istruzioni passo passo in 3D.

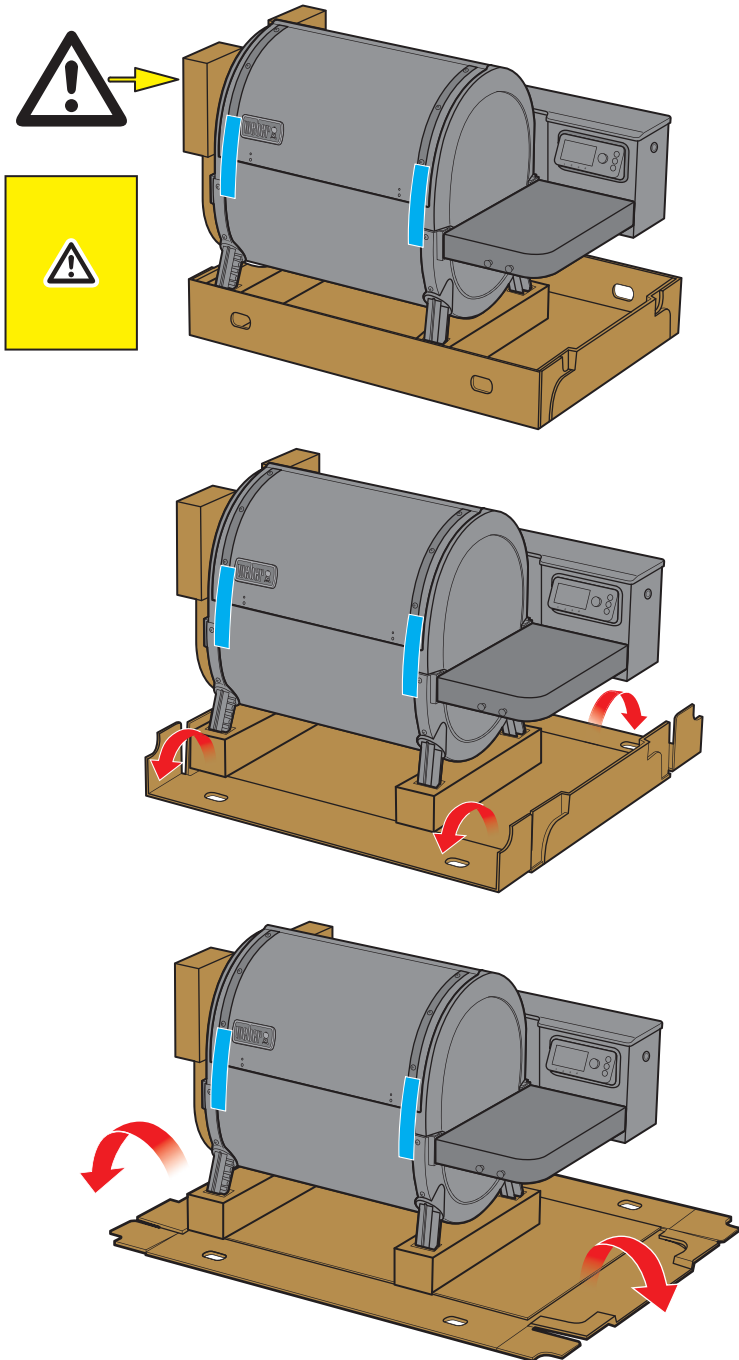

3

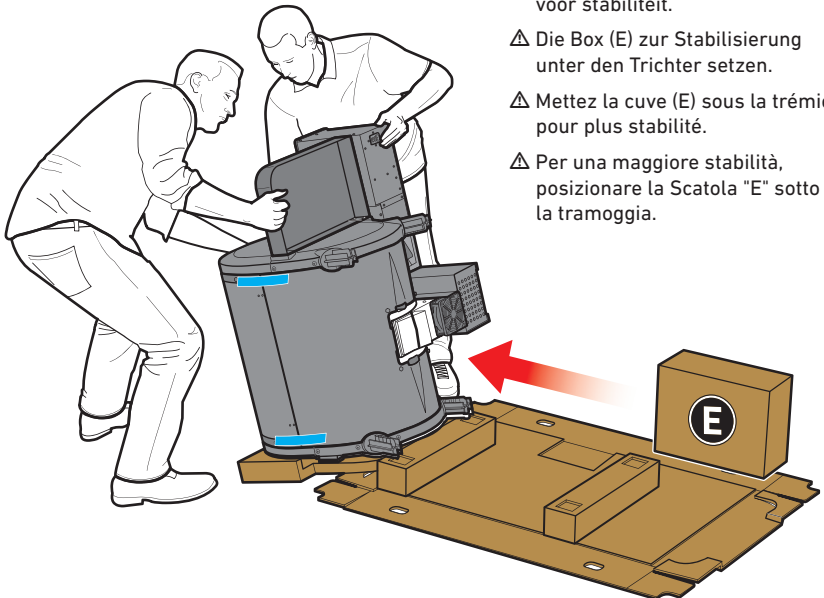
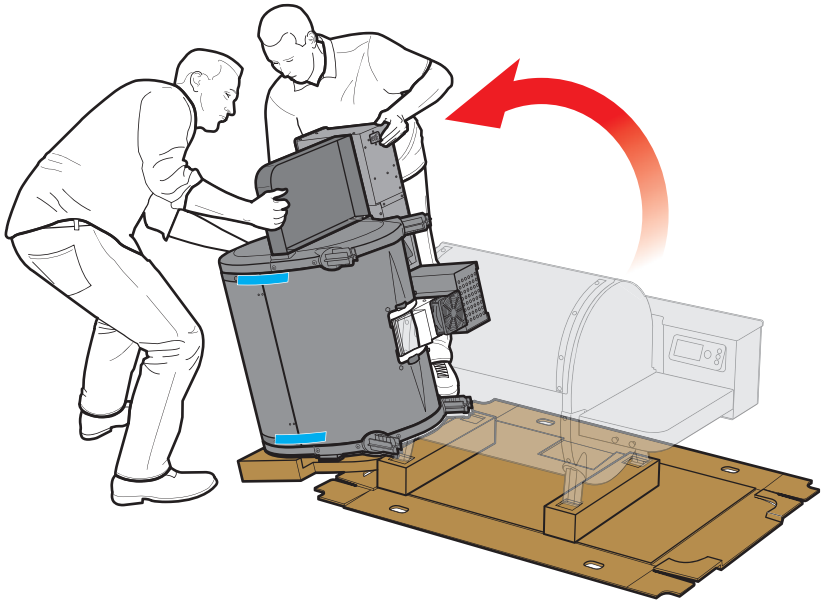

- ⚠ Zet doos E onder het reservoir voor stabiliteit.
- ⚠ Die Box (E) zur Stabilisierung unter den Trichter setzen.
- ⚠ Mettez la cuve (E) sous la trémie pour plus stabilité.
- ⚠ Per una maggiore stabilità, posizionare la Scatola "E" sotto la tramoggia.

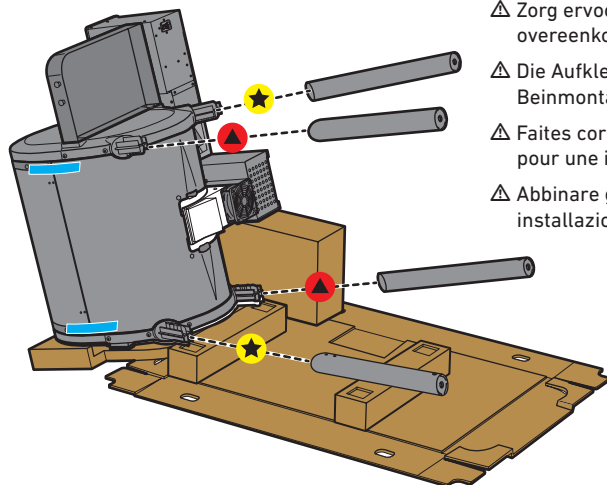
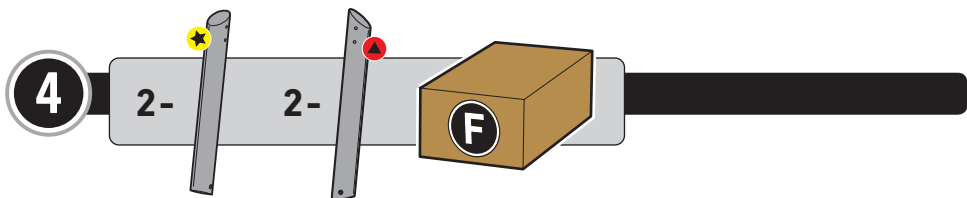

- △ Zorg ervoor dat de stickers op de poten overeenkomen voor een correcte installatie.
- △ Die Aufkleber für eine korrekte Beinmontage aneinander ausrichten.
- △ Faites correspondre les autocollants pour une installation correcte des pieds.
- △ Abbinare gli adesivi per una corretta installazione delle gambe.

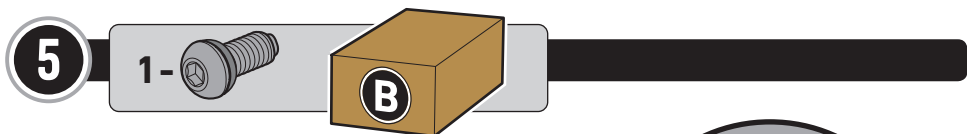

- △ Plaats de bovenste schroef slechts tot de helft in de poot.
- △ Die obere Schraube nur halb in das Bein einschrauben.
- △ Insérez la vis supérieure dans le pied à moitié uniquement.
- △ Inserire la vite superiore solo per metà nella gamba.

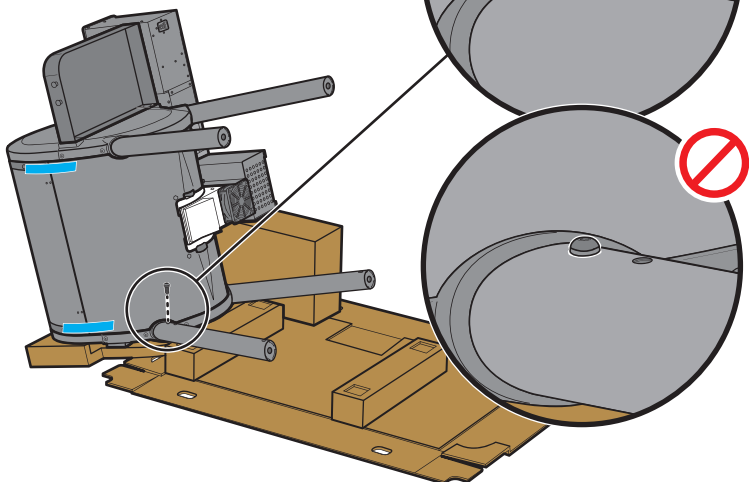

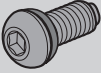
6**1-**

- ⚠ Plaats de bovenste schroef slechts tot de helft in de poot.
- ⚠ Die obere Schraube nur halb in das Bein einschrauben.
- ⚠ Insérez la vis supérieure dans le pied à moitié uniquement.
- ⚠ Inserire la vite superiore solo per metà nella gamba.

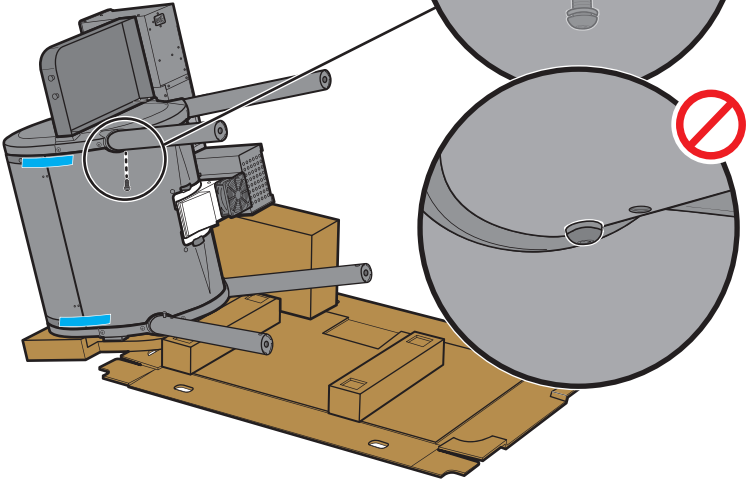
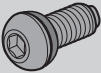
**7****2-**

- ⚠ Volledig strak aandraaien.
- ⚠ Vollständig Festziehen.
- ⚠ Serrage complet.
- ⚠ Serrare completamente.

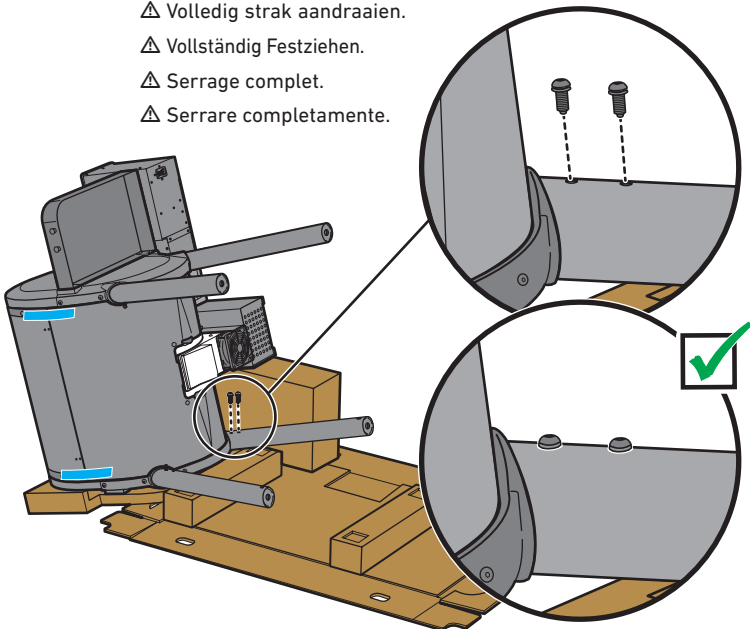

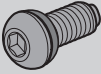
8**2-**

- △ Volledig strak aandraaien.
- △ Vollständig Festziehen.
- △ Serrage complet.
- △ Serrare completamente.

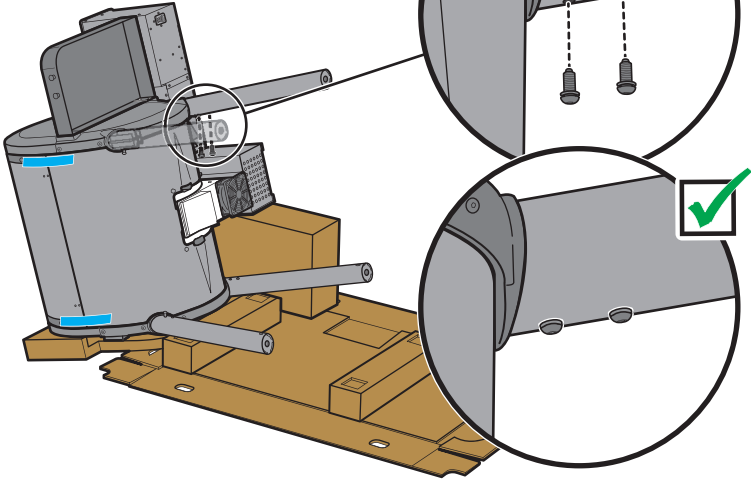
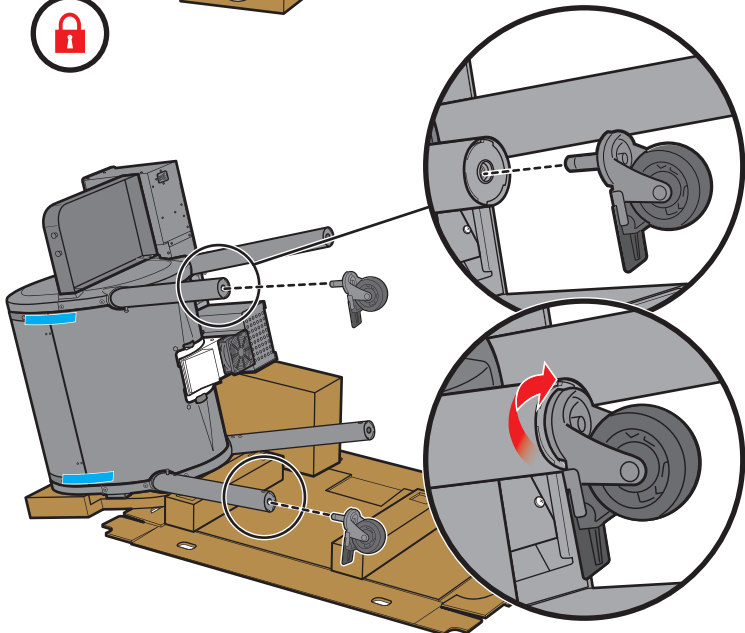
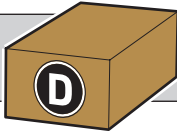
**9****2-**

10

2-

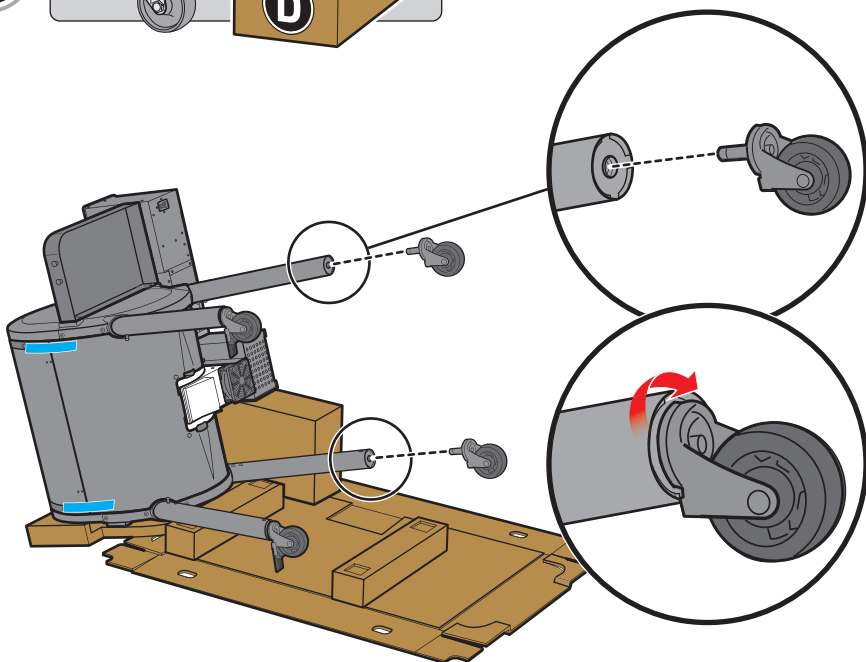
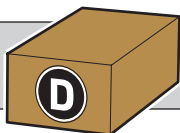

11

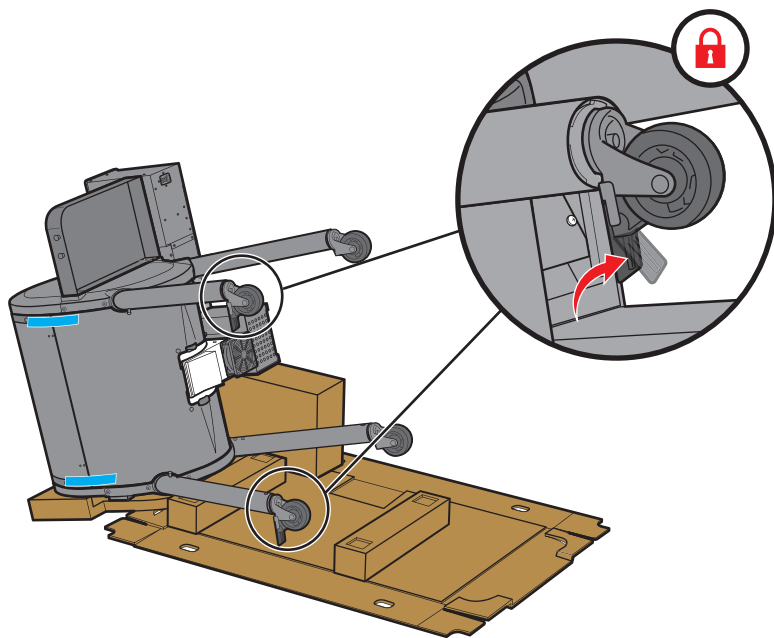

AAN
EIN
MARCHE
INSERITO

12

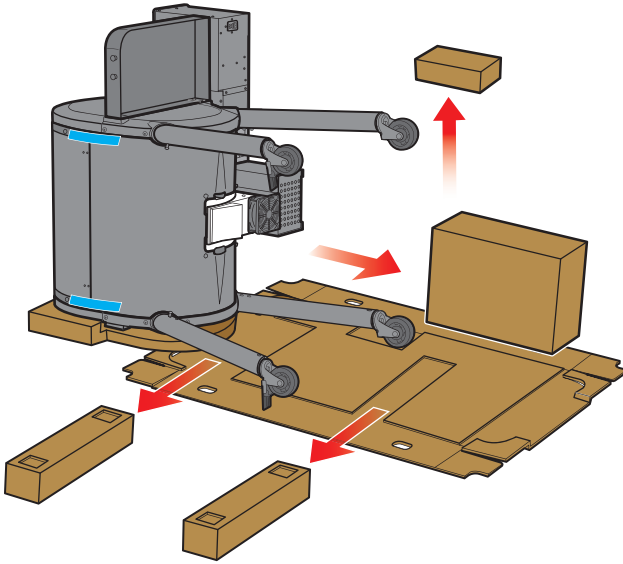

13

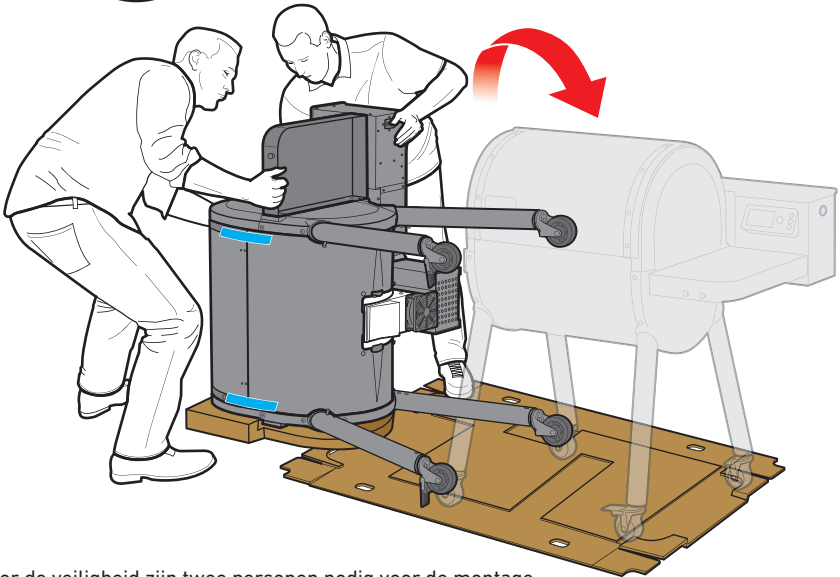

- ⚠ Voor de veiligheid zijn twee personen nodig voor de montage.
- ⚠ Aus Sicherheitsgründen sind zwei Personen erforderlich.
- ⚠ Pour des raisons de sécurité, deux personnes sont nécessaires.
- ⚠ Per motivi di sicurezza, sono necessarie due persone.

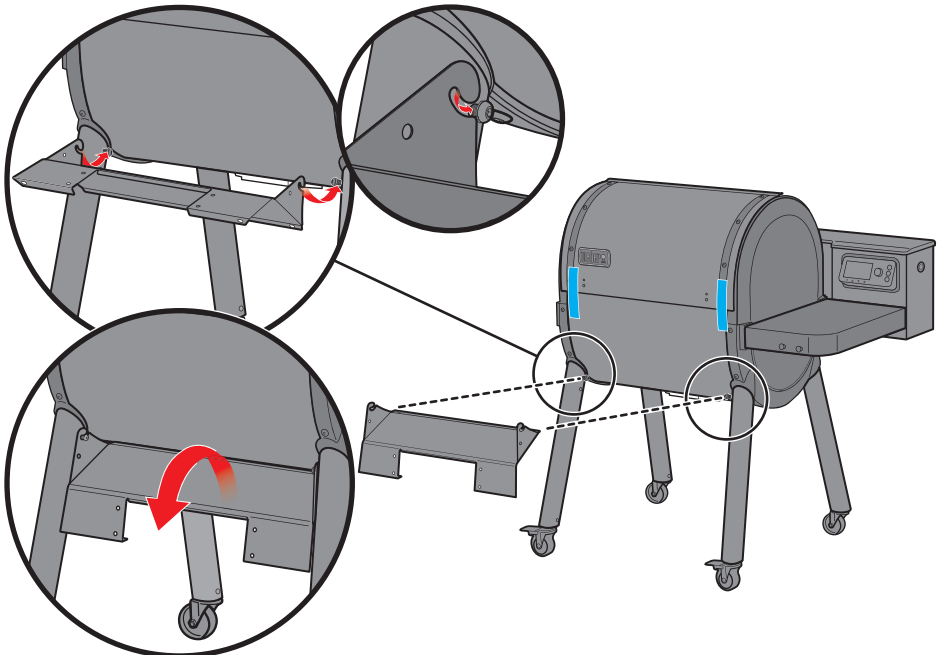
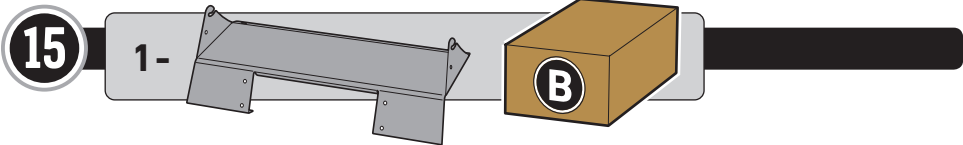
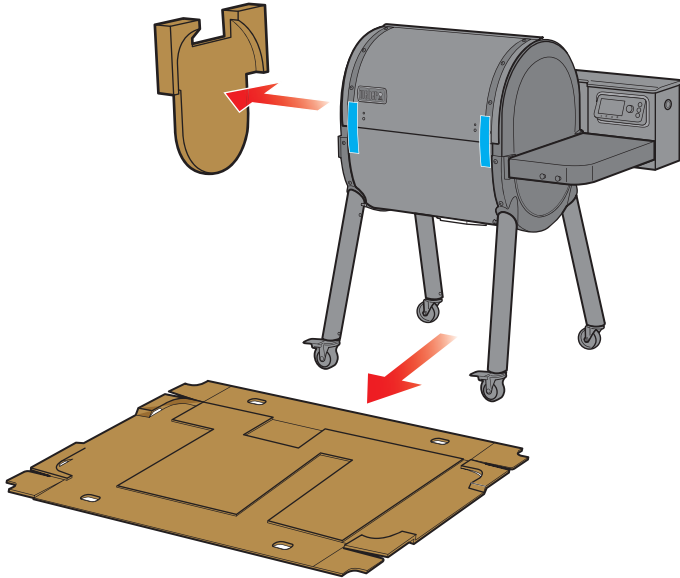

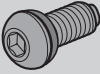
16**2-**

Bevestig de hardware totdat deze goed vast zit.

⚠ **DRAAI DE SCHROEVEN EN BOUTEN NIET TE VAST AAN.**

Befestigungsteile sicher festziehen.

⚠ **SCHRAUBEN NICHT ZU FEST ANZIEHEN.**

Serrez fermement les vis.

⚠ **NE SERREZ PAS TROP LES VIS.**

Stringere la minuteria fino a quando non è ben serrata.

⚠ **NON SERRARE ECCESSIVAMENTE LA MINUTERIA.**

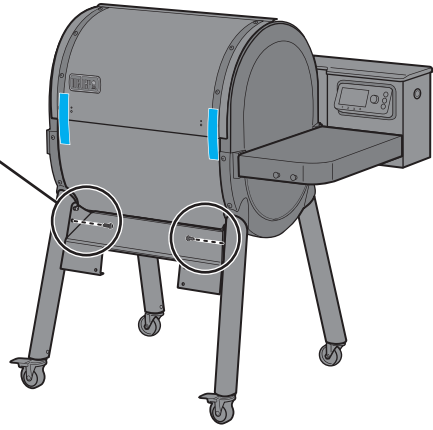
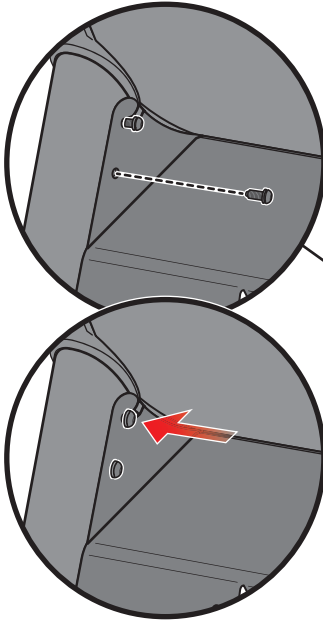
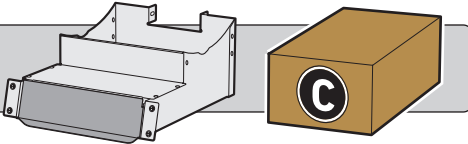
**17****1-**

⚠ Verwijder de as- en vetlade voordat je de behuizing installeert.

⚠ Vor dem Einbau des Gehäuses den Asche- und Fettaufangbehälter herausnehmen.

⚠ Retirez le tiroir à cendres et à graisses avant d'installer le boîtier.

⚠ Rimuovere il cassetto della cenere e del grasso prima di installare l'alloggiamento.

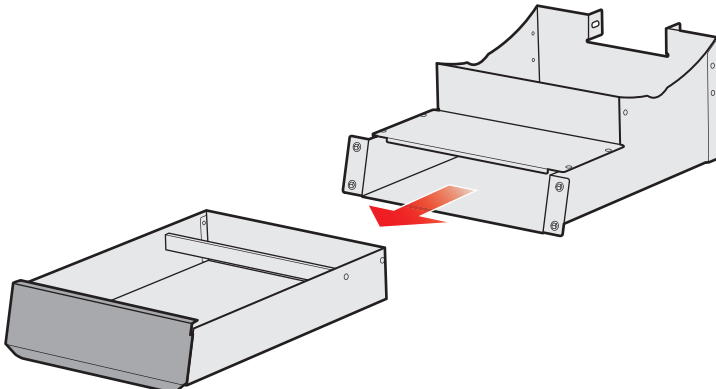

18

2-

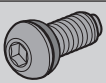

1-

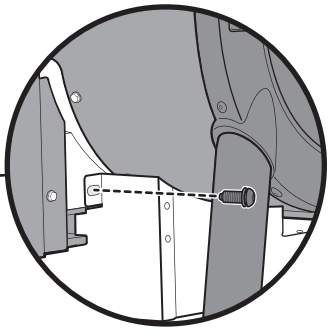
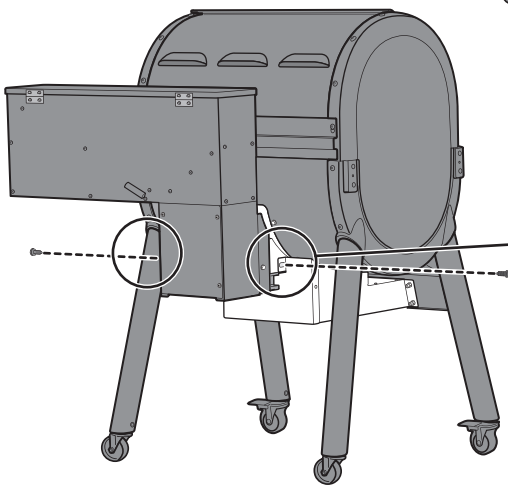
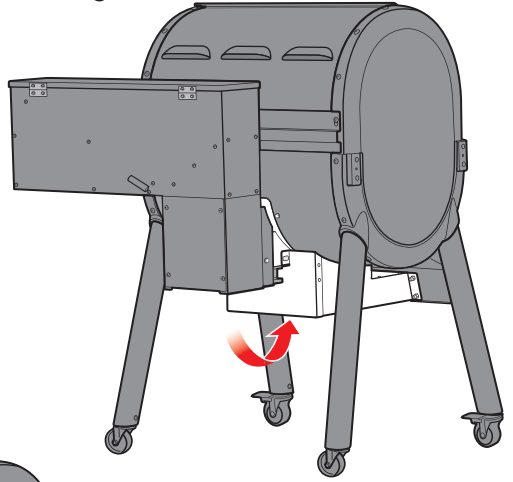
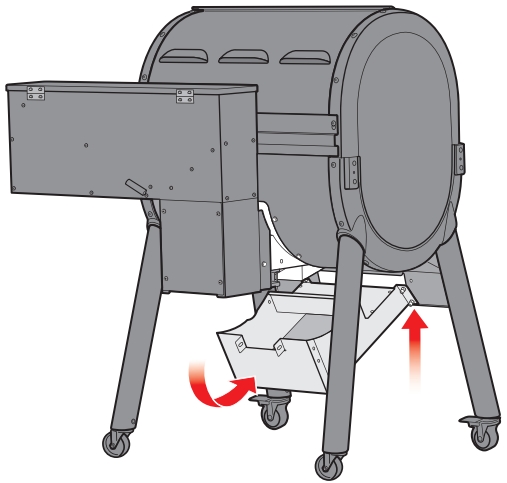
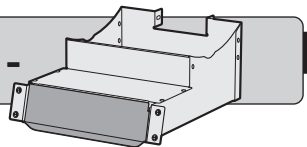

19

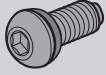
4- 

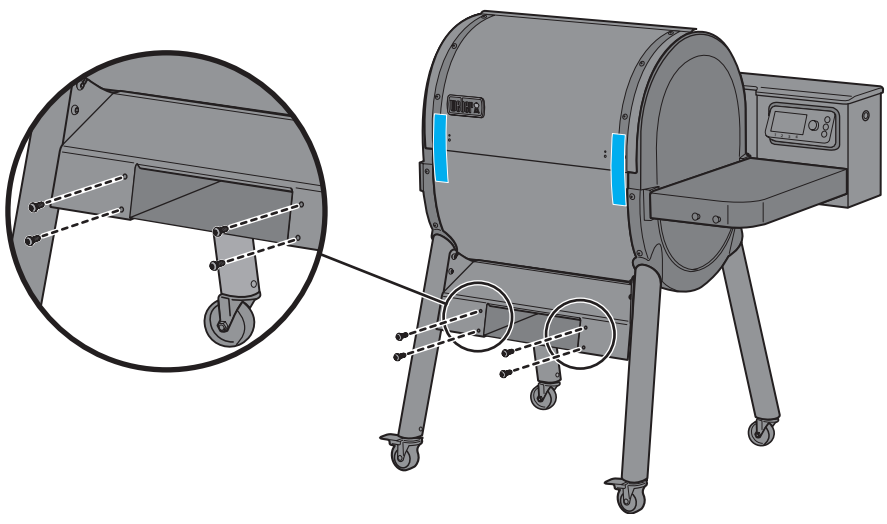

20

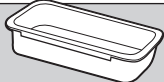
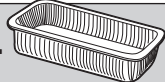
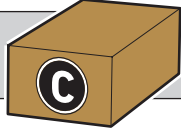
1-  1-  

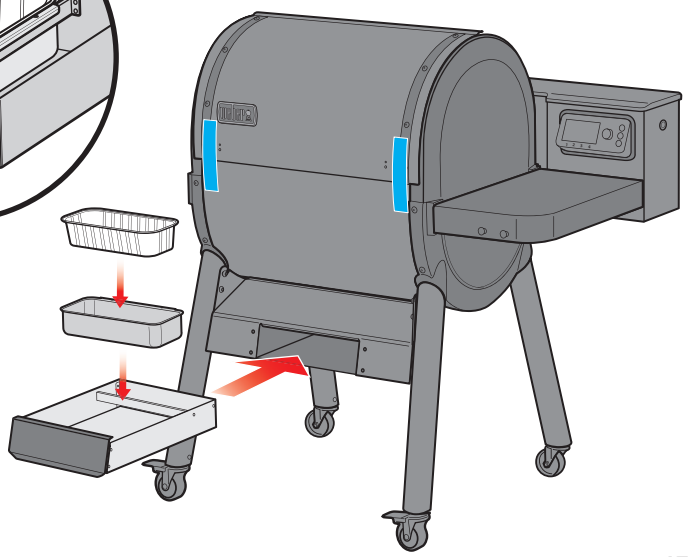
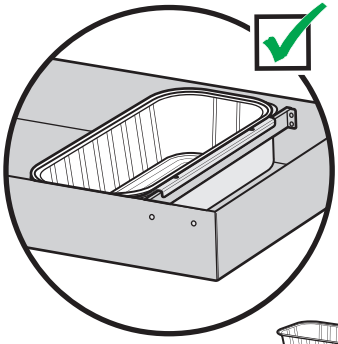

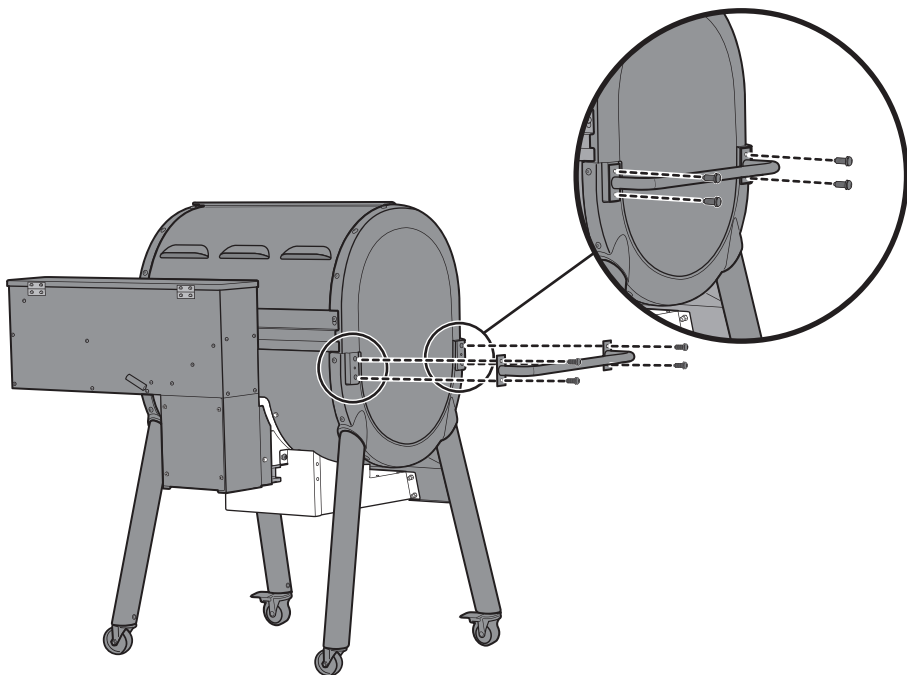
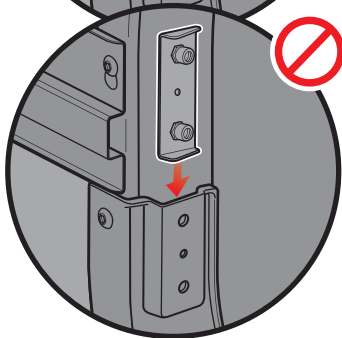
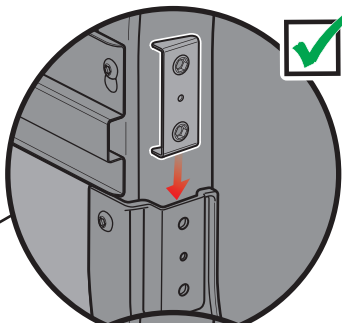
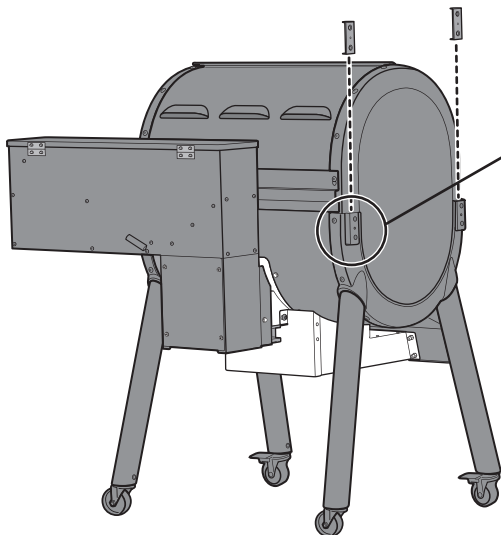
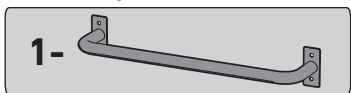
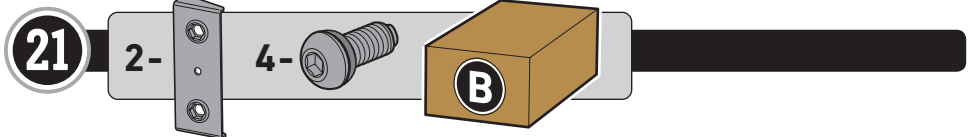

Verwijder de blauwe tape van het deksel.
Blaues Klebeband vom Deckel entfernen.
Retirez le ruban adhésif bleu du couvercle.
Retirez le ruban adhésif bleu du couvercle.

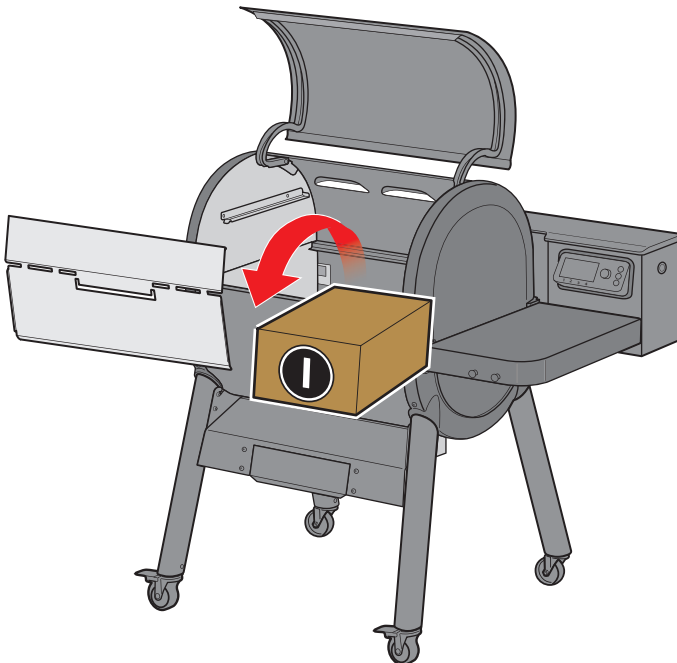
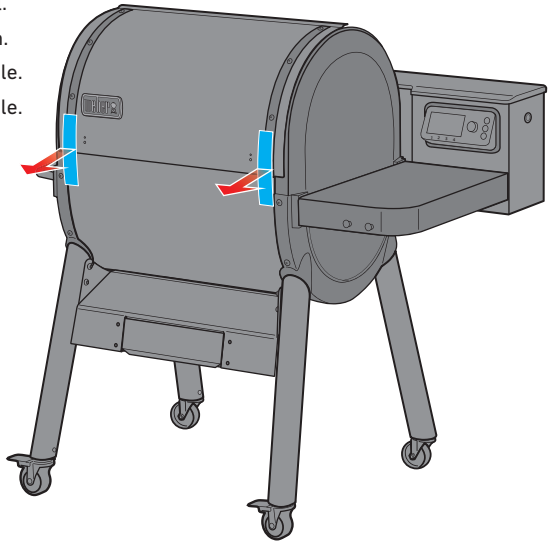

25

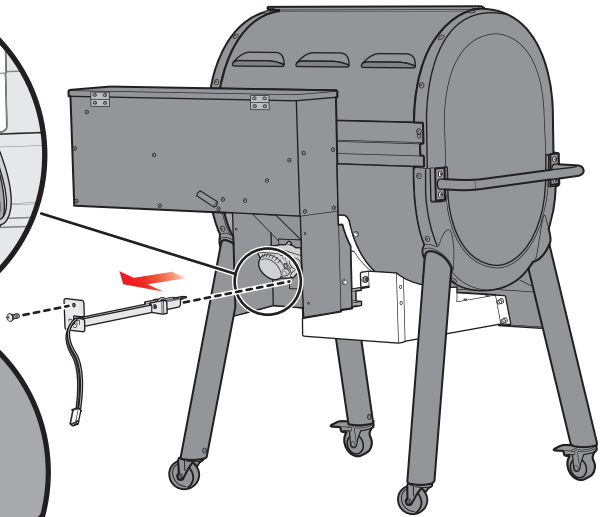
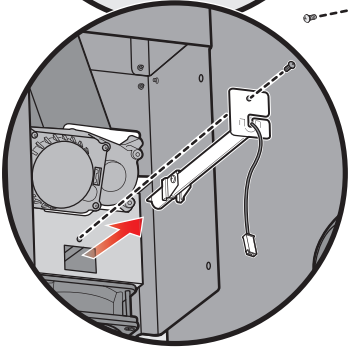
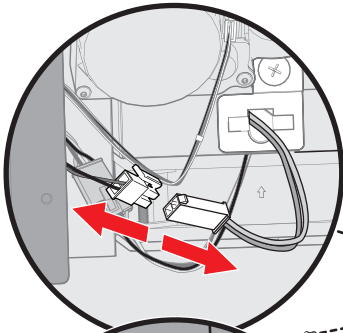
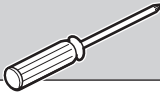

26

1-

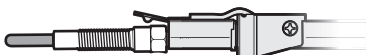
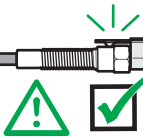
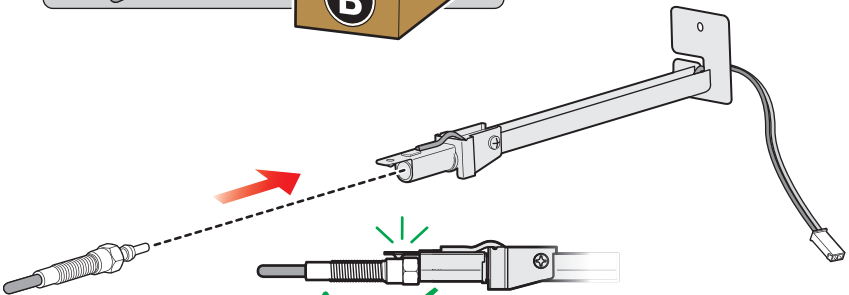
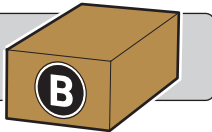
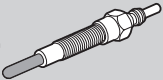

27

1-

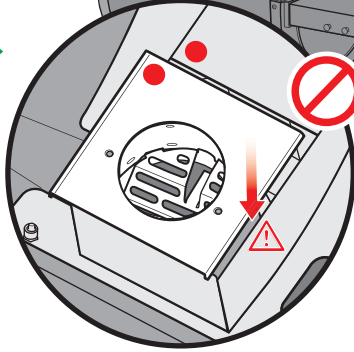
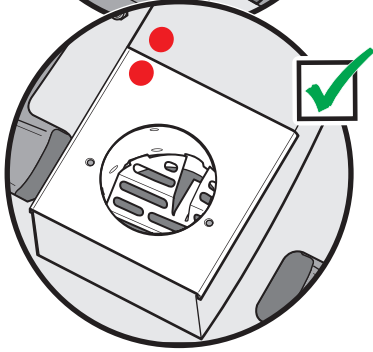
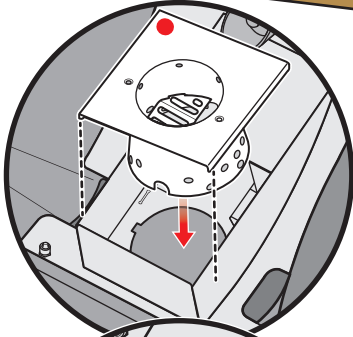
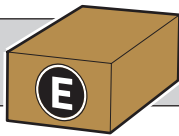
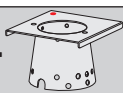

28

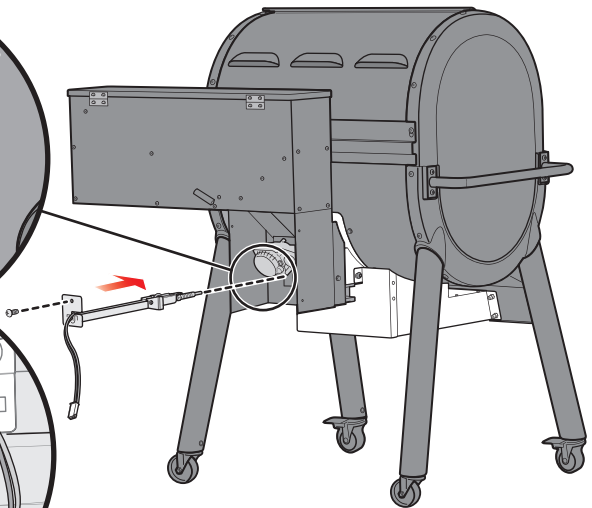
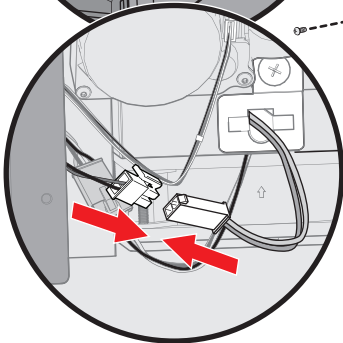
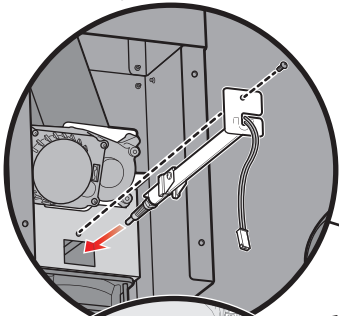
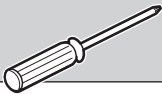

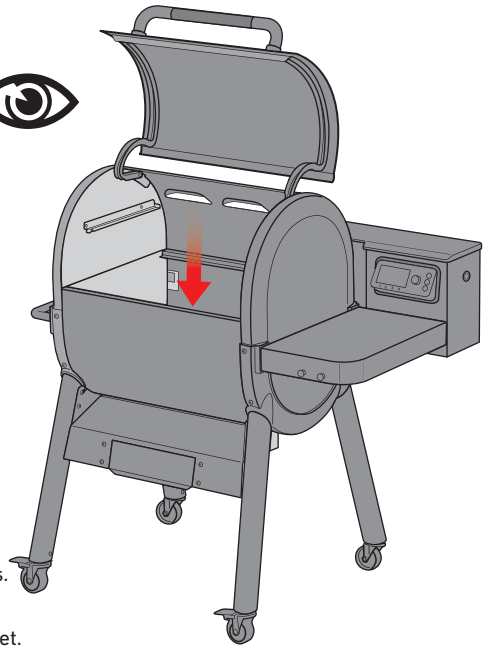
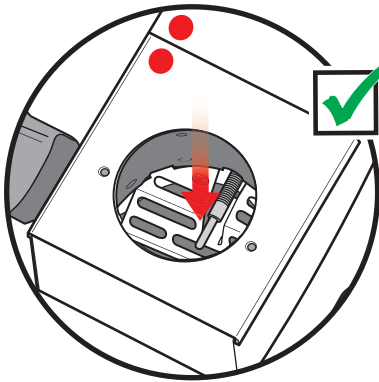

- ⚠ Kijk goed of het uiteinde van de gloeiplug door de opening van het pelletrooster is geplaatst.
- ⚠ Achte darauf, dass die Spitze der Glühkerze durch den Pelletrost eingeführt wird.
- ⚠ Assurez-vous que l'embout de la bougie de préchauffage est inséré dans la grille pour pellets.
- ⚠ Assicursarsi che la punta della candeletta sia posizionata al centro del foro della griglia del pellet.

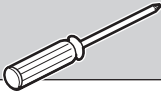

- ⚠ Controleer of alle draadverbindingen goed vastzitten voordat je het toegangspaneel aan de achterkant opnieuw installeert.
- ⚠ Achte darauf, dass alle Kabelverbindungen sicher angeschlossen sind, bevor du den rückseitigen Zugangsdeckel wieder anbringst.
- ⚠ Vérifiez tous les branchements avant de réinstaller le panneau d'accès arrière.
- ⚠ Assicursarsi che tutti i cavi siano stati adeguatamente collegati prima di rimontare il pannello di accesso posteriore.

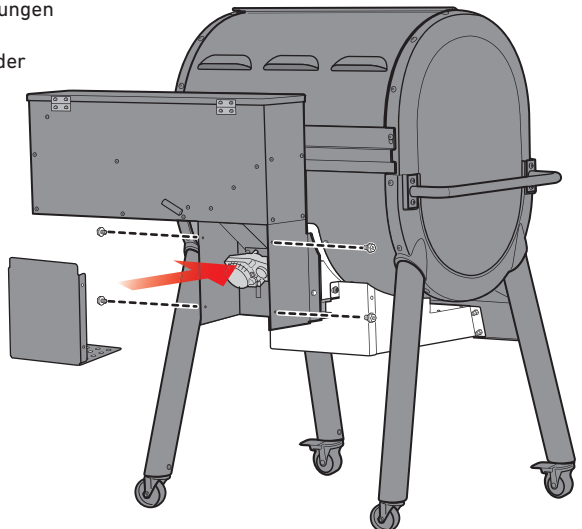

31

2-

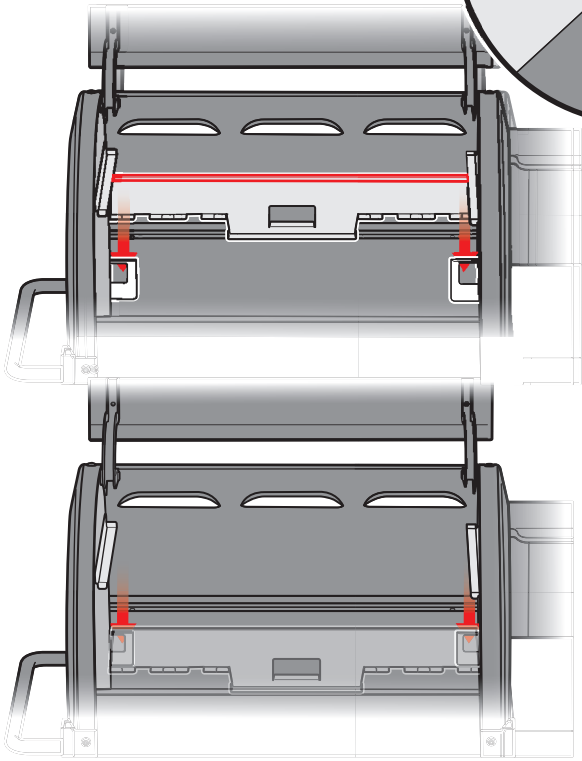
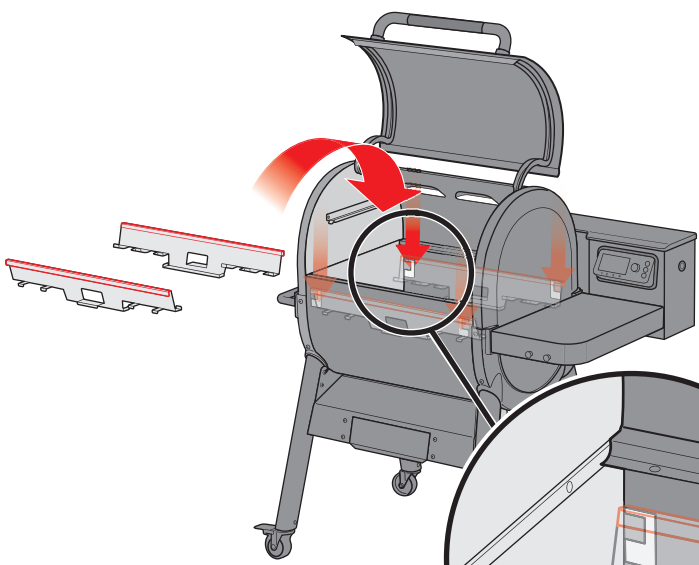
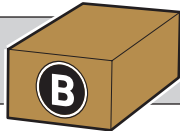

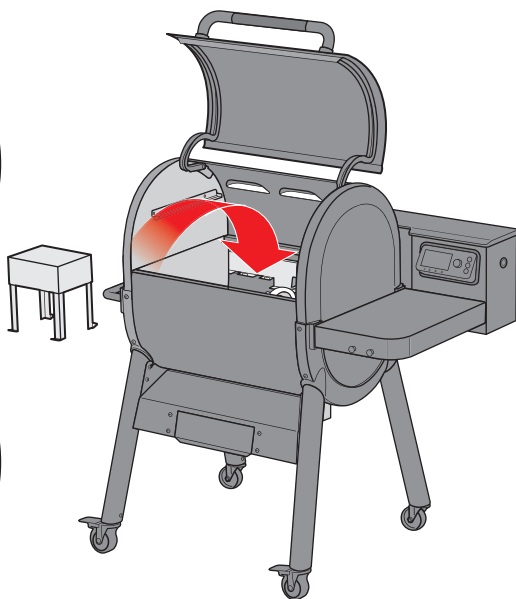
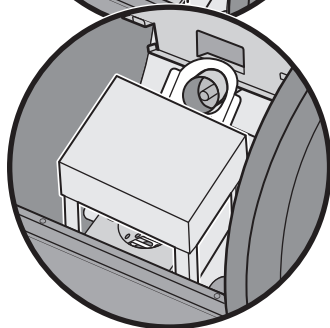
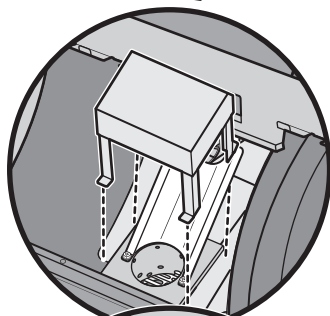
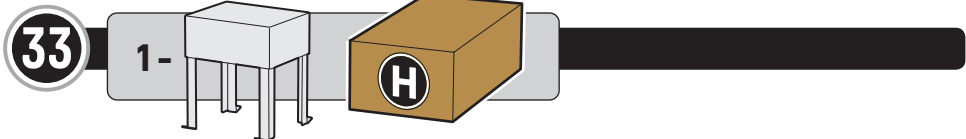
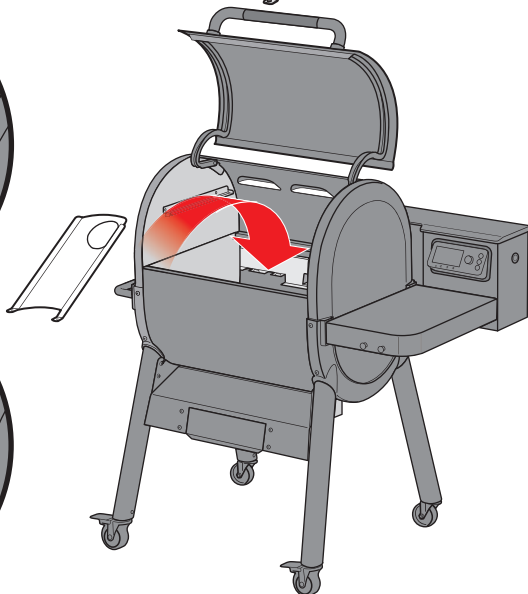
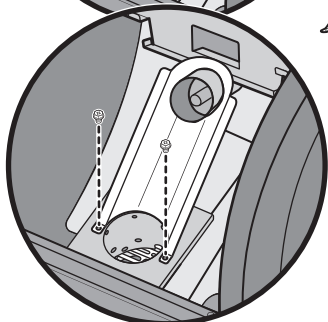
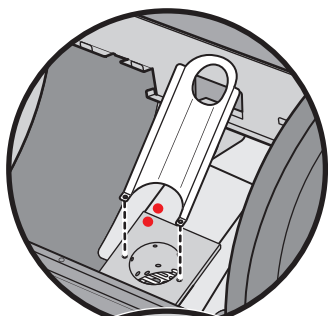
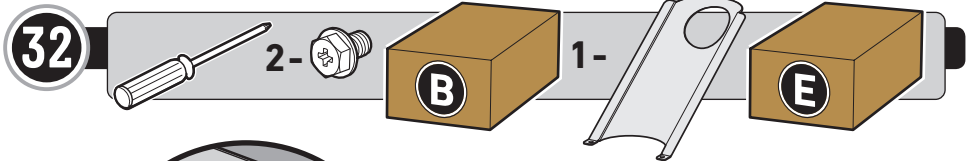

34

1-

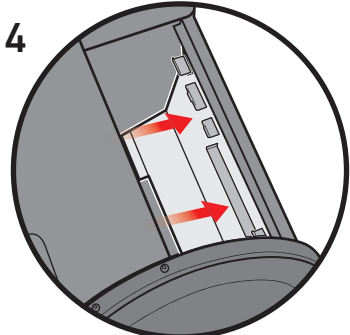
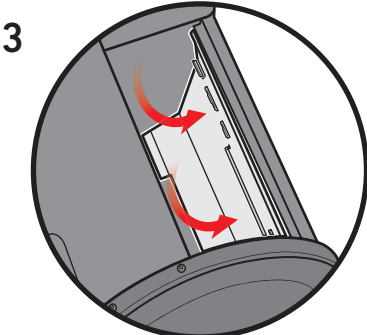
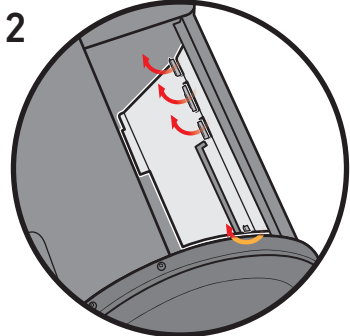
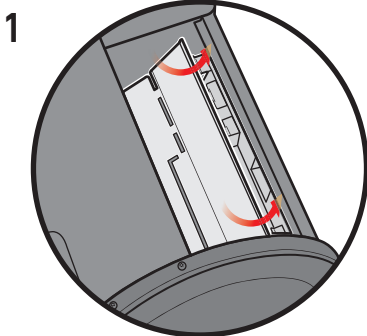
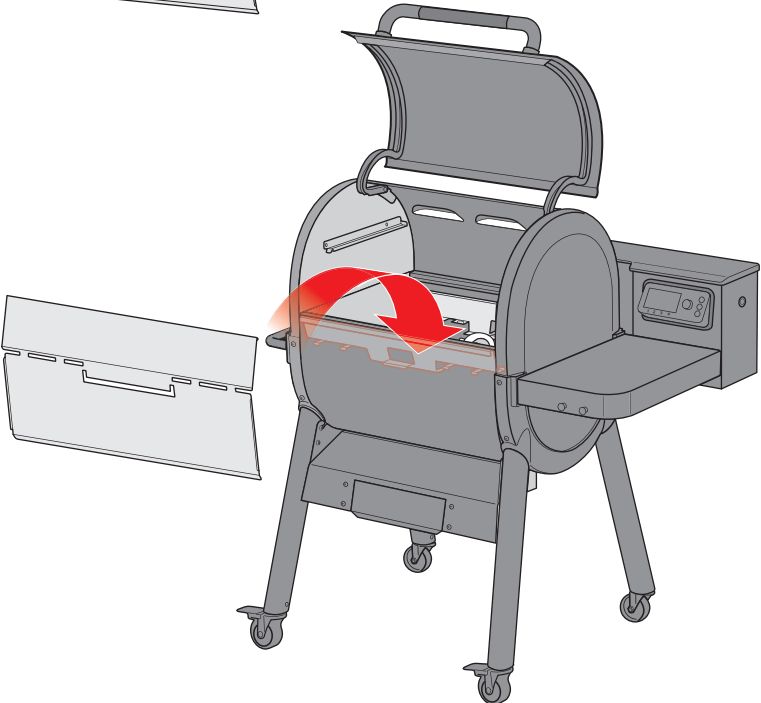
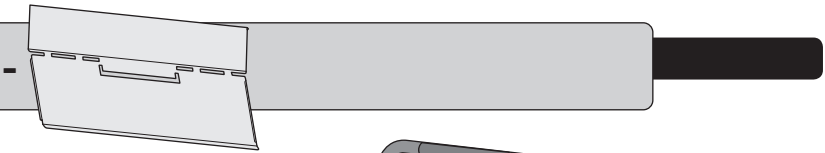

35

EPX4 4-

EPX6 6-

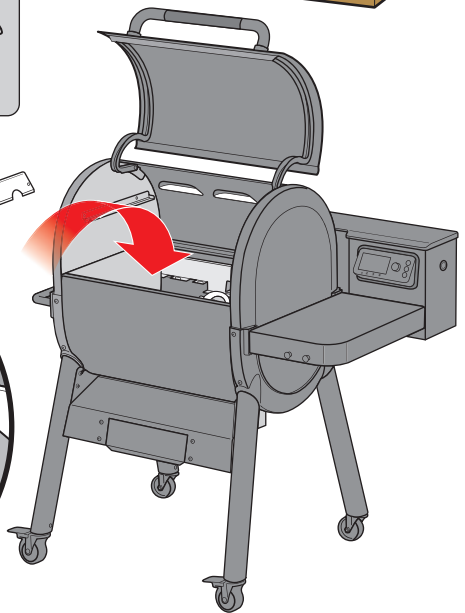
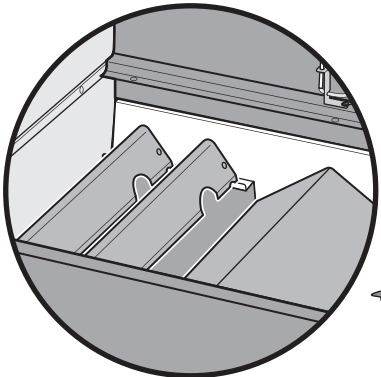
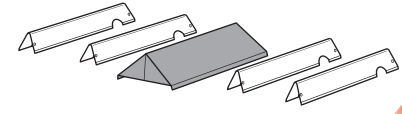
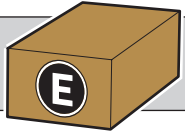

36

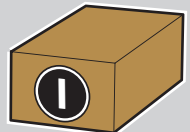
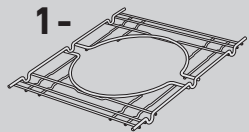
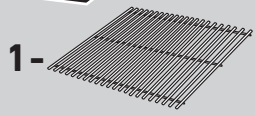
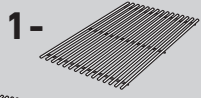

EPX4

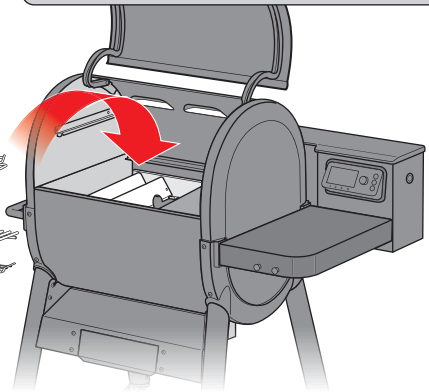
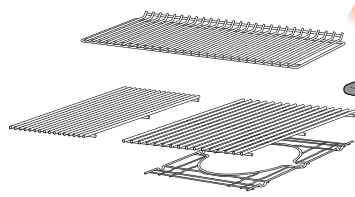

37

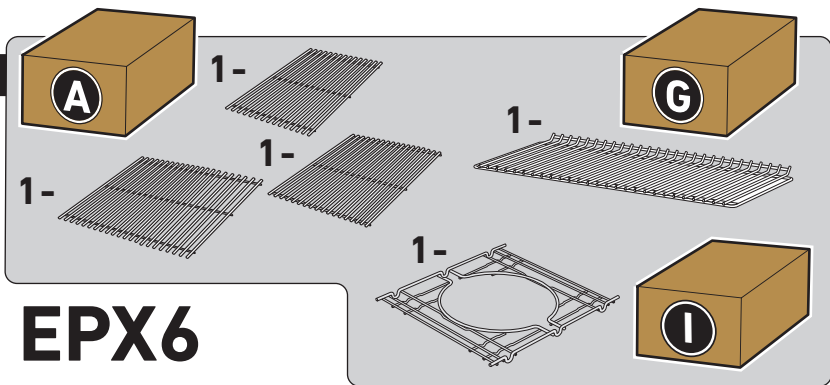

EPX6

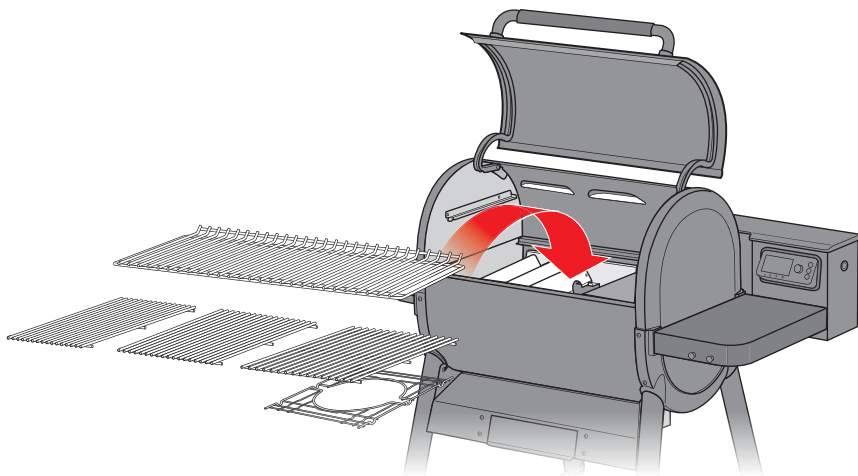

REGISTREER VANDAAG NOG.

Registreer je barbecue en ontvang exclusieve WEBER-content waarmee je de ultieme held in je achtertuin wordt.

REGISTRIERE DEINEN GRILL NOCH HEUTE.

Registriere deinen Grill, um exklusive WEBER Inhalte zu erhalten, mit denen du zum ultimativen Grillhelden wirst.

ENREGISTREZ-VOUS AUJOURD'HUI

Enregistrez votre barbecue pour recevoir des informations exclusives de WEBER qui feront de vous le ou la Grill Master du barbecue.

REGISTRATI OGGI STESSO.

Registra il tuo barbecue per ricevere contenuti WEBER esclusivi che ti faranno diventare un vero re della griglia.



WEBER-STEPHEN PRODUCTS LLC
www.weber.com