



SUMMIT

GRILL OWNER'S GUIDE

Thank you for purchasing a WEBER grill. Take a few minutes and protect it by registering your product online at www.weber.com.



E-670 · S-670

LP

YOU MUST READ THIS OWNER'S GUIDE BEFORE OPERATING YOUR GAS GRILL.

⚠ DANGER

If you smell gas:

- 1) Shut off gas to the appliance.**
- 2) Extinguish any open flames.**
- 3) Open lid.**
- 4) If odour continues, keep away from the appliance and immediately call your gas supplier or your fire service.**

Leaking gas may cause a fire or explosion which can cause serious bodily injury, death, or damage to property.

⚠ WARNING: Carefully follow all leak-check procedures in this Owner's Guide prior to grill operation. Do this even if the grill was dealer-assembled.

⚠ WARNING: Do not ignite this appliance without first reading the BURNER IGNITION sections of this Owner's Guide.

OUTDOOR USE ONLY.

NOTICE TO INSTALLER: These instructions must be left with the owner, who should keep them for future use.

⚠ WARNING

- 1) Do not store or use petrol or other flammable liquids or vapours in the vicinity of this or any other appliance.**
- 2) A gas supply cylinder not connected for use shall not be stored in the vicinity of this or any other appliance.**

CE :845BR-0035
ID: 0845

59841

EN - ENGLISH
04/01/18

WARNINGS

⚠ DANGER

Failure to follow the Dangers, Warnings and Cautions contained in this Owner's Manual may result in serious bodily injury or death, or in a fire or an explosion causing damage to property.

⚠ WARNINGS

- ⚠ Follow regulator connection instructions for your type of gas grill.
- ⚠ Do not store a spare or disconnected gas supply cylinder under or near this grill.
- ⚠ Do not put a grill cover or anything flammable on or in the storage area under the grill.
- ⚠ Improper assembly may be dangerous. Please carefully follow the assembly instructions in this manual.
- ⚠ After a period of storage and/or non-use, the gas grill should be checked for gas leaks and burner obstructions before use. Refer to instructions in this manual for correct procedures.
- ⚠ Do not use a flame to check for gas leaks.
- ⚠ Do not operate your gas grill if there are any leaking gas connections.
- ⚠ Flammable materials should not be present within approximately 60 cm of the back or sides of the grill.
- ⚠ Your gas grill should not be used by children. Accessible parts of the grill may be very hot. Keep young children away while it is in use.
- ⚠ Exercise caution when using your gas grill. It will be hot during cooking or cleaning, and should never be left unattended, or moved while in operation.
- ⚠ If the burners should go out during cooking, turn off all gas valves. Open the lid and wait five minutes before attempting to re-light the gas flame, while observing the lighting instructions.
- ⚠ Do not use charcoal, briquettes or lava rock in your gas grill.
- ⚠ While cooking, never lean over the open grill or place hands or fingers on the front edge of the cooking box.
- ⚠ Should an uncontrolled flare-up occur, move food away from the flames until flaring subsides.
- ⚠ Should a grease fire occur, turn off all burners and leave lid closed until fire is out.
- ⚠ The gas grill should be cleaned thoroughly at regular intervals.
- ⚠ When cleaning valves or burners, do not enlarge orifices or ports.
- ⚠ Liquid propane gas is not natural gas. The conversion or attempted use of natural gas in an LP gas unit is dangerous and will void your warranty.
- ⚠ A dented or rusty gas supply cylinder may be hazardous and should be checked by your gas supplier. Do not use a gas supply cylinder with a damaged valve.
- ⚠ Even though your gas supply cylinder may appear to be empty, it might still contain gas. The cylinder should be transported and stored accordingly.
- ⚠ Under no circumstances should you attempt to disconnect the gas regulator or any gas fitting while your grill is in operation.
- ⚠ Use heat-resistant barbecue mitts or gloves (conforming to EN 407, Contact Heat rating level 2 or greater) when operating barbecue.
- ⚠ Do not use this grill unless all parts are in place. The unit must be properly assembled according to the instructions outlined in the "Assembly Instructions".
- ⚠ Do not put a fuel tank inside the cabinet.
- ⚠ Do not build this model of grill in any built-in or slide-in construction. Ignoring this warning could cause a fire or an explosion that may damage property or cause serious bodily injury or death. ♦

TABLE OF CONTENTS

WARNINGS	2	SIDE BURNER IGNITION & USAGE	20
TABLE OF CONTENTS	3	SIDE BURNER IGNITION	20
EXPLODED VIEW	4	TO EXTINGUISH	20
WARRANTY	5	SIDE BURNER MANUAL IGNITION.....	20
GENERAL INSTRUCTIONS	6	TO EXTINGUISH	20
STORAGE.....	6	SEAR STATION IGNITION & USAGE	21
OPERATING	7	SEAR STATION BURNER IGNITION	21
GAS INSTRUCTIONS	7	TO EXTINGUISH	21
SAFE HANDLING TIPS FOR LP GAS CYLINDERS	7	SEAR STATION BURNER MANUAL IGNITION.....	22
INSTALLING THE CYLINDER	8	TO EXTINGUISH	22
CYLINDER INSTALLATION LOCATION OPTIONS	8	USING THE SEAR STATION.....	22
CONNECTING THE LPG CYLINDER	9	SMOKER BURNER IGNITION & USAGE	23
LEAK-CHECK PREPARATION	10	SMOKER BURNER IGNITION	23
CHECK FOR GAS LEAKS.....	11	TO EXTINGUISH	23
REFILLING THE LPG CYLINDER	13	SMOKER BURNER MANUAL IGNITION.....	24
RECONNECT THE LPG CYLINDER	13	TO EXTINGUISH	24
LIGHT FEATURES	13	USING THE SMOKER	25
GRILL LIGHT OPERATION.....	13	CLEANING THE SMOKER	25
ILLUMINATED CONTROL KNOBS.....	13	ROTISSERIE BURNER IGNITION & USAGE	26
BEFORE USING THE GRILL	14	ROTISSERIE BURNER IGNITION	26
SLIDE-OUT GREASE TRAY AND DISPOSABLE DRIP PAN	14	TO EXTINGUISH	26
HOSE INSPECTION	14	ROTISSERIE BURNER MANUAL IGNITION	27
SNAP IGNITION OPERATION	15	TO EXTINGUISH	27
MAIN BURNER IGNITION & USAGE	16	IMPORTANT SAFEGUARDS	28
MAIN BURNER IGNITION	16	OPERATING THE ROTISSERIE	28
TO EXTINGUISH	16	ROTISSERIE COOKING	29
MAIN BURNER MANUAL IGNITION	17	ROTISSERIE MOTOR STORAGE	29
TO EXTINGUISH	17	ROTISSERIE SPIT STORAGE	29
GRILLING TIPS & HELPFUL HINTS	18	TROUBLESHOOTING	30
PREHEATING	18	SIDE BURNER TROUBLESHOOTING	30
COVERED COOKING.....	18	SEAR STATION TROUBLESHOOTING	31
DRIPPINGS AND GREASE	18	ROTISSERIE TROUBLESHOOTING	31
FLAVORIZER® SYSTEM	18	GRILL LIGHT TROUBLESHOOTING	31
SEAR STATION	18	MAINTENANCE	32
COOKING METHODS	19	CLEANING.....	32
DIRECT COOKING	19	PRESERVE YOUR STAINLESS STEEL.....	32
INDIRECT COOKING.....	19	WEBER SPIDER/INSECT SCREENS	32
		BURNER TUBE CLEANING	32
		REPLACING MAIN BURNERS.....	33
		SIDE BURNER MAINTENANCE.....	34
		ANNUAL MAINTENANCE	35
		MAINTAINING THE GRILL LIGHT	35

EXPLODED VIEW

SUMMIT E-670/S-670_LP_EN_110117

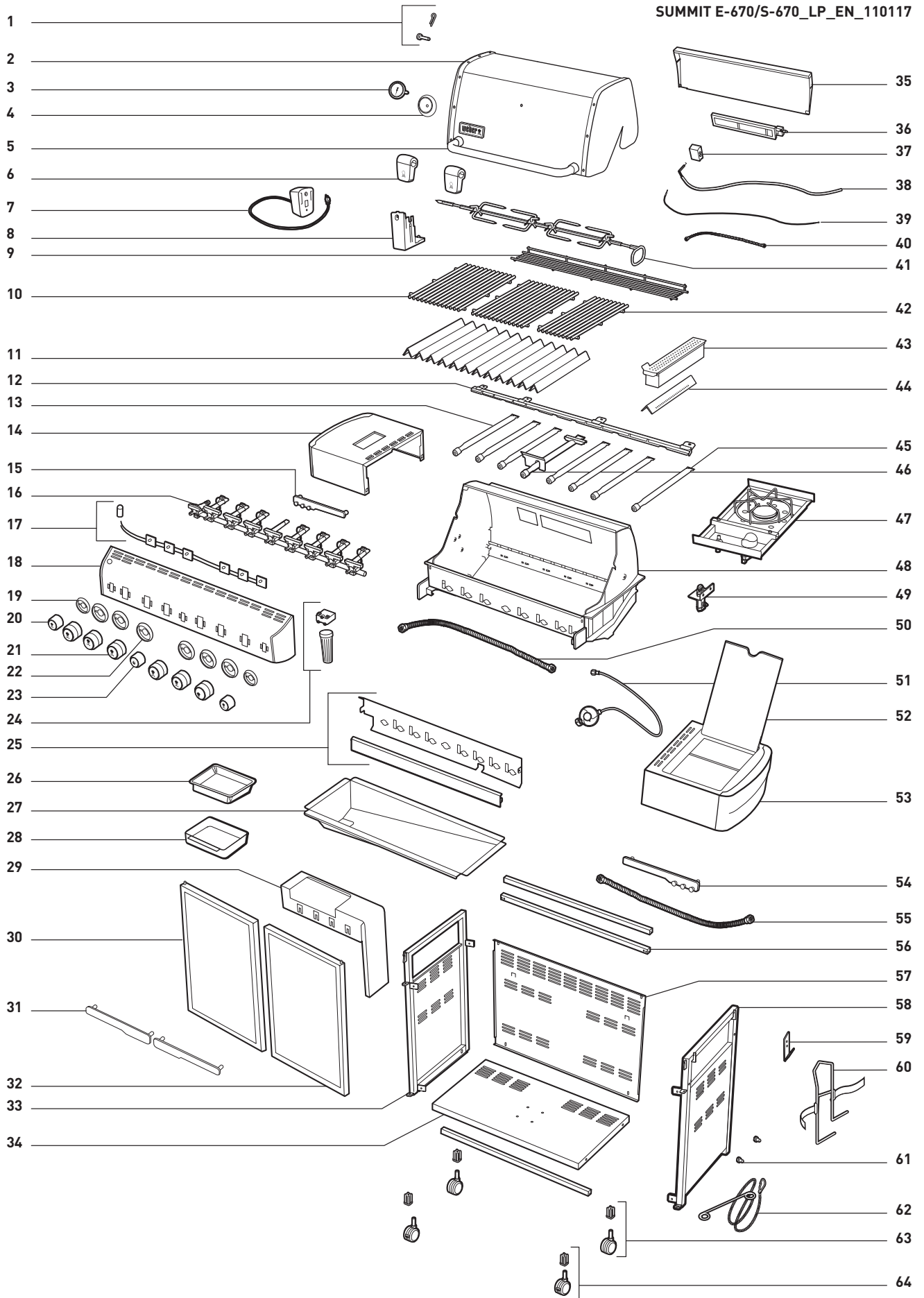

The WEBER Promise (10 year EMEA voluntary warranty)

At WEBER, we pride ourselves on two things: making barbecues that last and providing a lifetime of excellent customer service.

Thank you for purchasing a WEBER product. Weber-Stephen Products LLC, 1415 S. Roselle Road, Palatine, Illinois 60067 and its International Business Units (listed at the end of this manual) ("WEBER") pride ourselves on delivering a safe, durable, and reliable product.

This is WEBER's Voluntary Warranty provided to you at no extra charge. It contains the information you will need to have your WEBER product repaired or replaced in the unlikely event of a failure or defect.

Pursuant to applicable laws, the Owner has several rights in case the product is defective. Those rights may include supplementary performance or replacement, abatement of the purchasing price, and compensation. In some countries in the European Union, for example, this would be a two-year statutory right starting on the date of the handover of the product. These and other statutory rights remain unaffected by this Voluntary Warranty provision. In fact, this Voluntary Warranty grants additional rights to the Owner that are independent from statutory provisions.

WEBER's Voluntary Warranty

WEBER warrants, to the Purchaser of the WEBER product (or in case of a gift or promotional situation, the person for whom it was purchased as a gift or promotional item) ("Owner") that the WEBER product is free from defects in material and workmanship for ten (10) years from the date of purchase when assembled and operated in accordance with the accompanying Owner's Manual. (Note: If you lose or misplace your WEBER Owner's Manual, a replacement is available online at www.weber.com) The Warranty is applicable in Europe, the Middle East and Africa (EMEA). WEBER agrees to repair or replace the part that is defective in material or workmanship subject to the limitations, disclaimers, and exclusions listed below. TO THE EXTENT ALLOWABLE BY APPLICABLE LAW, THIS WARRANTY IS EXTENDED ONLY TO THE ORIGINAL PURCHASER AND IS NOT TRANSFERABLE TO SUBSEQUENT OWNERS, EXCEPT IN THE CASE OF GIFTS AND PROMOTIONAL ITEMS AS NOTED ABOVE.

WEBER stands by its products and is happy to provide you with this Voluntary Warranty described for material defects in the barbecue or its relevant components, normal wear and tear excepted.

- 'Normal wear and tear' includes cosmetic and other immaterial deterioration that may come with ownership of your barbecue over time, such as surface rust, dents / scratches, etc.

However, WEBER will honour this Voluntary Warranty for the barbecue or its relevant components where damage or dysfunction results from a material defect.

- 'Material defect' includes rust through or burn through of certain parts, or other damage or failure inhibiting your ability to safely / properly use your barbecue.

Owner's Responsibilities Under this Voluntary Warranty / Exclusion of Warranty

To ensure trouble-free Warranty coverage, it is important (but not required) that you register your WEBER product online at www.weber.com. Please also retain your original sales receipt and/or invoice as Proof of Purchase is required for Warranty coverage. WEBER will also require photographs of any alleged defect, and the serial number of your barbecue, prior to processing a Warranty claim. Registering your WEBER product confirms your Warranty coverage and provides a direct link between you and WEBER in case we need to contact you.

The above Voluntary Warranty only applies if the Owner takes reasonable care of the WEBER product by following all assembly instructions, usage instructions, and preventative maintenance as outlined in the accompanying Owner's Manual, unless the Owner can prove that the material defect or failure is independent of non-compliance with the above mentioned obligations. If you live in a coastal area, or have your product located near a pool, maintenance includes regular washing and rinsing of the exterior surfaces as outlined in the accompanying Owner's Manual.

This Voluntary Warranty lapses if there are damages, deteriorations, discolourations, and/or rust for which WEBER is not responsible caused by:

- Abuse, misuse, alteration, modification, misapplication, vandalism, neglect, improper assembly or installation, and failure to properly perform normal and routine maintenance;
- Insects (such as spiders) and rodents (such as squirrels), including but not limited to damage to gas hoses;
- Exposure to salt air and/or chlorine sources such as swimming pools and hot tubs/spas;
- Severe weather conditions such as hail, hurricanes, earthquakes, tsunamis or surges, tornadoes or severe storms.
- Acid rain and other environmental factors.

The use and/or installation of parts on your WEBER product that are not genuine WEBER parts will void this Voluntary Warranty, and any damages that result hereby are not covered by this Voluntary Warranty. Any conversion of a gas barbecue not authorised by WEBER and performed by a WEBER authorized service technician will void this Voluntary Warranty.

Warranty Processing

If you believe that you have a part which is covered by this Voluntary Warranty, please contact your purchase dealer. If needed, you may also contact WEBER Customer Service using the contact information on our website (www.weber.com). WEBER will, upon investigation, repair or replace (at its option) a defective part that is covered by this Voluntary Warranty. In the event that repair or replacement are not possible, WEBER may choose (at its option) to replace the barbecue in question with a new barbecue of equal or greater value. WEBER may ask you to return parts for inspection, shipping charges to be pre-paid by the Owner. The shipping charges will be reimbursed to the Owner if the defect is covered by the Warranty.

When you contact your purchase dealer, please have the following information available:

- Proof of Purchase
- Photographs of the alleged defect
- Product serial number

Disclaimers

APART FROM THE WARRANTY AND DISCLAIMERS AS DESCRIBED IN THIS VOLUNTARY WARRANTY STATEMENT, THERE ARE EXPLICITLY NO FURTHER WARRANTY OR VOLUNTARY DECLARATIONS OF LIABILITY GIVEN HERE WHICH GO BEYOND THE STATUTORY LIABILITY APPLYING TO WEBER. THE PRESENT VOLUNTARY WARRANTY STATEMENT ALSO DOES NOT LIMIT OR EXCLUDE SITUATIONS OR CLAIMS WHERE WEBER HAS MANDATORY LIABILITY AS PRESCRIBED BY STATUTE.

NO WARRANTIES SHALL APPLY AFTER THE TEN (10) YEAR PERIOD OF THIS VOLUNTARY WARRANTY. NO OTHER WARRANTIES GIVEN BY ANY PERSON, INCLUDING A DEALER OR RETAILER, WITH RESPECT TO ANY PRODUCT (SUCH AS ANY "EXTENDED WARRANTIES"), SHALL BIND WEBER. THE EXCLUSIVE REMEDY OF THIS VOLUNTARY WARRANTY IS REPAIR OR REPLACEMENT OF THE PART OR PRODUCT.

IN NO EVENT UNDER THIS VOLUNTARY WARRANTY SHALL RECOVERY OF ANY KIND BE GREATER THAN THE AMOUNT OF THE PURCHASE PRICE OF THE WEBER PRODUCT SOLD.

PARTS AND ACCESSORIES REPLACED UNDER THIS VOLUNTARY WARRANTY ARE WARRANTED ONLY FOR THE REMAINING PERIOD OF THE ABOVE MENTIONED ORIGINAL TEN (10) YEAR VOLUNTARY WARRANTY PERIOD.

THIS LIMITATION DOES NOT APPLY IN CASES OF INTENT AND GROSS NEGLIGENCE AND CASES OF INJURY TO HUMAN LIFE OR HEALTH OR PERSONAL INJURY WHETHER THE INJURY WAS THE FAULT OF WEBER OR ITS LEGAL REPRESENTATIVES OR AGENTS.

THIS VOLUNTARY WARRANTY APPLIES TO PRIVATE USE ONLY AND DOES NOT APPLY TO WEBER BARBECUES USED IN COMMERCIAL, COMMUNAL OR MULTI-UNIT SETTINGS SUCH AS RESTAURANTS, HOTELS, RESORTS, OR RENTAL PROPERTIES.

WEBER MAY FROM TIME TO TIME CHANGE THE DESIGN OF ITS PRODUCTS. NOTHING CONTAINED IN THIS VOLUNTARY WARRANTY SHALL BE CONSTRUED AS OBLIGATING WEBER TO INCORPORATE SUCH DESIGN CHANGES INTO PREVIOUSLY MANUFACTURED PRODUCTS, NOR SHALL SUCH CHANGES BE CONSTRUED AS AN ADMISSION THAT PREVIOUS DESIGNS WERE DEFECTIVE.

GENERAL INSTRUCTIONS

Your WEBER gas grill is a portable outdoor cooking appliance. With the WEBER gas grill you can grill, barbecue, roast and bake with results that are difficult to duplicate with indoor kitchen appliances. The closed lid and FLAVORIZER BARS produce that "outdoor" flavour in the food.

The WEBER gas grill is portable so you can easily change its location in your garden or on your patio. Portability means you can take your WEBER gas grill with you if you move.

Liquid Propane (LP) gas is quicker to use and gives you more cooking control than charcoal fuel.

- These instructions will give you the minimum requirements for assembling your WEBER gas grill. We therefore request that you read them carefully before you use the WEBER gas grill.
- Not for use by children.
- Do not connect to natural gas supply (city gas). The valves and orifices are designed exclusively for LP gas.
- Not to be used with charcoal briquettes or lava rock.
- Use only a 3kg-13kg LP gas cylinder.
- In the United Kingdom, this appliance must be fitted with a regulator complying with BS 3016, having a nominal output of 37 millibars. (Supplied with grill.)
- Avoid kinking the hose.

- The length of hose must not exceed 1.5 metres.
- We recommend that you replace the gas hose on your WEBER gas grill every 5 years. Some countries may have requirements that the gas hose be replaced within less than 5 years, in which case that country's requirement would take precedence.
- Any parts sealed by the manufacturer must not be altered by the user.
- Any modification of the appliance may be dangerous.
- Only a nationally approved low-pressure hose and regulator must be used.
- Replacement pressure regulators and hose assemblies must be those specified by the outdoor cooking gas appliance manufacturer. ♦

STORAGE

- When the WEBER gas grill is not being used, turn off the gas supply cylinder valve.
- When storing the WEBER gas grill indoors, disconnect the gas supply line. The gas cylinder itself is to be stored outdoors in a well-ventilated place.
- If the gas supply cylinder is not removed from the WEBER gas grill, the entire grill and the gas supply cylinder are to be stored in a well-ventilated place outdoors.
- Gas supply cylinders must be stored outdoors in a well-ventilated area out of reach of children. Disconnected gas supply cylinders must not be stored in a building, garage or any other enclosed area. ♦

GENERAL INSTRUCTIONS

OPERATING

- ⚠ **WARNING:** This appliance is intended for outdoor use only and should never be used in garages and roofed or enclosed porches or verandas.
- ⚠ **WARNING:** The WEBER gas grill must never be used under an unprotected combustible roof or overhang.
- ⚠ **WARNING:** The grill should not be used when combustible materials are within 60 cm of the top, bottom, back or sides of the grill.
- ⚠ **WARNING:** Your WEBER gas grill is not intended to be installed in or on caravans and/or boats.
- ⚠ **WARNING:** When in use, the entire grill gets hot. Never leave it unattended.

- ⚠ **WARNING:** Keep electrical mains lead and the fuel supply hose away from heated surfaces.
- ⚠ **WARNING:** Keep the cooking area clear of flammable vapours and liquids, such as petrol, alcohol, etc., and combustible materials.
- ⚠ **WARNING:** Never store an extra (spare) gas supply cylinder near the WEBER gas grill.
- ⚠ **WARNING:** This appliance gets very hot. Take special care when children or elderly people are present.
- ⚠ **WARNING:** Do not move the appliance while it is alight.
- ⚠ **WARNING:** Use heat-resistant barbecue mitts or gloves (conforming to EN 407, Contact Heat rating level 2 or greater) when operating barbecue. ♦

GAS INSTRUCTIONS

SAFE HANDLING TIPS FOR LP GAS CYLINDERS

- Liquid Propane (LP) gas is a petroleum product as are petrol and natural gas. LP gas is a gas at normal temperatures and pressures. Under moderate pressure, inside a cylinder, LP gas is a liquid. As the pressure is released, the liquid readily vapourises and becomes gas.
- LP gas has an odour similar to natural gas. You should be aware of this odour.
- LP gas is heavier than air. Leaking LP gas may collect in low areas and prevent dispersion.
- The LPG cylinder must be installed, transported and stored in an upright position. LPG cylinders should not be dropped or handled roughly.
- Never store or transport the LPG cylinder where temperatures can reach 51°C (too hot to hold by hand - for example: do not leave the LPG cylinder in a car on a hot day).
- Handle "empty" LPG cylinders with the same care as when full. Even when the LPG cylinder is empty of liquid there still may be gas pressure in the cylinder. Always close the cylinder valve before disconnecting.
- Do not use a damaged LPG cylinder. Dented or rusty LPG cylinders or LPG cylinders with a damaged valve may be hazardous and should be replaced with a new one immediately.
- The joint where the hose connects to the LPG cylinder must be leak-tested each time the LPG cylinder is reconnected. For example, test each time the LPG cylinder is refilled.
- Be sure the regulator is mounted with the small vent hole pointed downward so that it will not collect water. This vent should be free of dirt, grease, insects, etc. ♦

COUNTRY	GAS TYPE & PRESSURE
Bulgaria, Cyprus, Czech Republic, Denmark, Estonia, Finland, Hungary, Iceland, Latvia, Lithuania, Malta, Netherlands, Norway, Romania, Slovak Republic, Slovenia, Sweden, Turkey	I ₃ B/P - 30 mbar
Belgium, France, Greece, Ireland, Italy, Luxembourg, Portugal, Spain, Switzerland, United Kingdom	I ₃ , - 28-30 / 37 mbar
Poland	I ₃ P - 37 mbar
Austria, Germany	I ₃ B/P - 50 mbar

CONSUMPTION DATA				
	Propane kW	Butane kW	Propane g/h	Butane g/h
SUMMIT 620	21.1	24.0	1,508	1,747
SUMMIT 660	25.8	29.4	1,844	2,139
SUMMIT 670	29.3	33.4	2,094	2,431
Grill Centre	33.7	38.3	2,409	2,787

VALVE ORIFICE SIZE				
	LPG Gas			
	I ₃ B/P - 30 mbar	I ₃ , - 28-30 / 37 mbar	I ₃ B/P - 50 mbar	
MAIN BURNER VALVES				
SUMMIT 620	0.89	0.85	0.86	
SUMMIT 660	0.89	0.85	0.86	
SUMMIT 670	0.89	0.85	0.86	
Grill Centre	0.89	0.85	0.86	
SIDE BURNER VALVE				
SUMMIT 620	0.98	0.94	0.85	
SUMMIT 660	NA	NA	NA	
SUMMIT 670	0.98	0.94	0.85	
Grill Centre	1.39 and 0.44	1.33 and 0.43	1.23 and 0.40	
SEAR BURNER VALVE				
SUMMIT 620	NA	NA	NA	
SUMMIT 660	0.91	0.85	0.79	
SUMMIT 670	0.91	0.85	0.79	
Grill Centre	0.91	0.85	0.79	
SMOKER BURNER VALVE				
SUMMIT 620	NA	NA	NA	
SUMMIT 660	0.74	0.70	0.66	
SUMMIT 670	0.74	0.70	0.70	
Grill Centre	0.74	0.70	0.70	
IR BURNER VALVE				
SUMMIT 620	NA	NA	NA	
SUMMIT 660	0.94	0.86	0.82	
SUMMIT 670	0.94	0.86	0.86	
Grill Centre	0.94	0.86	0.86	

GAS INSTRUCTIONS

INSTALLING THE CYLINDER

Purchase A Full Cylinder Of Gas From Your Gas Dealer

The cylinder must always be installed, transported and stored in an upright position. Never allow the cylinder to drop or be handled carelessly. Never store the cylinder where temperatures can exceed 51° C (too hot to hold by hand). For example, do not leave the cylinder in your car on hot days. (Refer to: "SAFE HANDLING TIPS FOR LP GAS CYLINDERS"). ♦

CYLINDER INSTALLATION LOCATION OPTIONS

You may mount the cylinder to the right side panel using the cylinder hanger or place the cylinder on the ground. The cylinder must be placed outside the base cabinet, on the right side of the grill. Do not attempt to install the cylinder inside the base cabinet.

Cylinder Hanger Installation

You will need: the cylinder hanger bracket (1) and cylinder hanger (2).

- Position the cylinder hanger bracket on the right outside panel of the grill. Fasten with screws, washers and nuts (3).
- Install the cylinder glides (4) into the two holes below the cylinder hanger bracket. Fasten with screws, washers and nuts.
- Turn the cylinder so the valve opening faces the front of the grill.
- Hold the cylinder hanger and tilt the cylinder so the two bent supports of the cylinder hanger are located underneath the cylinder base flange. Adjust the belt so that it is tight to the cylinder (5).
- Lift and place the cylinder hanger on the cylinder hanger bracket as shown (6).

Ground Placement

- Place the cylinder on the ground, outside the base cabinet, on the right side of the grill (7).
- Turn the LP cylinder so the opening of the valve is facing the front of the WEBER gas grill. ♦

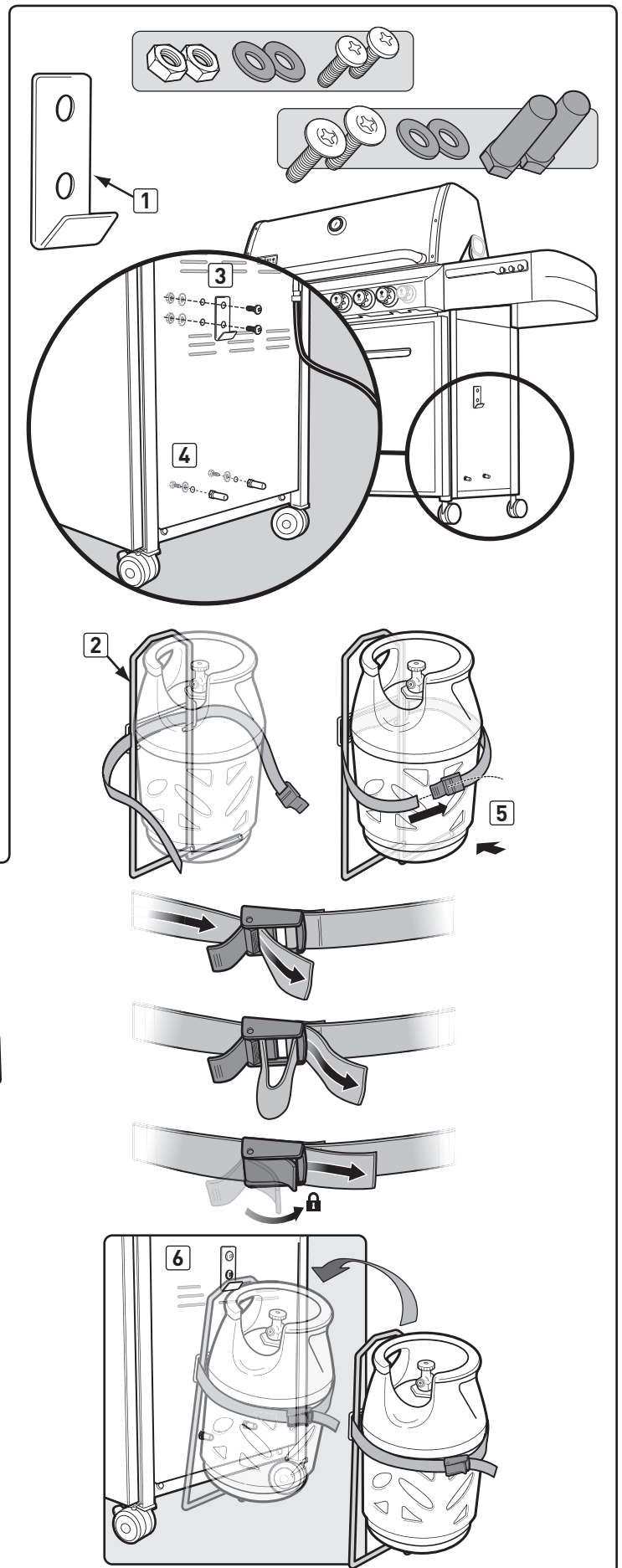

The grills illustrated in this Owner's Guide may vary slightly from the model purchased.

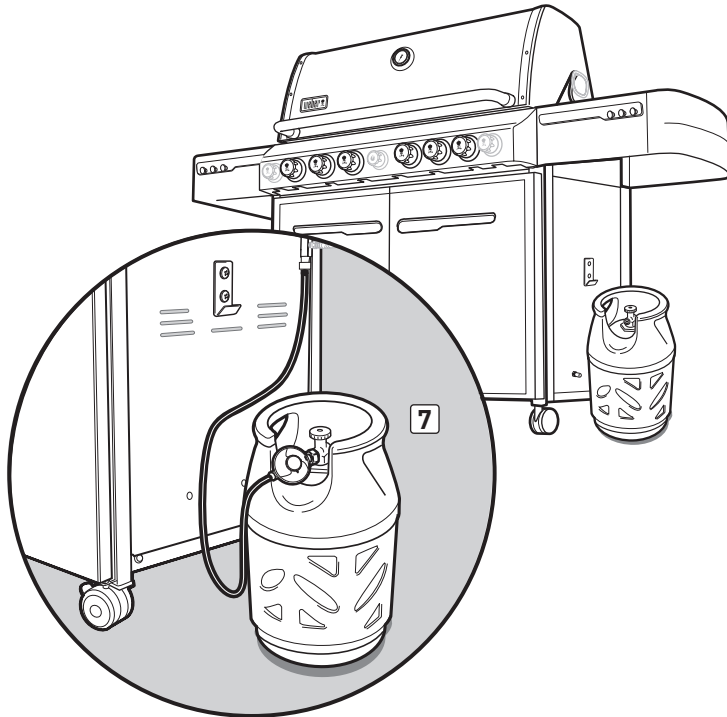

GAS INSTRUCTIONS

CONNECTING THE LPG CYLINDER

⚠ WARNING: Make sure that the LPG cylinder or regulator valve is closed.

A) Connect LPG cylinder.

Some regulators push ON to connect, and pull OFF to disconnect, others have a nut that has a left-hand thread that connects to the cylinder valve. Follow one of the specific regulator connection instructions illustrated based on your regulator type.

- a) Screw regulator fitting onto tank turning clockwise (1). Position the regulator so that the vent hole (2) faces down.
- b) Screw regulator fitting onto tank turning anti-clockwise (3) (4).
- c) Turn regulator lever (5) clockwise to the off position. Push regulator down on tank valve until regulator snaps into position (6).
- d) Make sure regulator lever is in the off position. Slide the collar of the regulator up (7) (9). Push the regulator down onto the tank valve and maintain pressure. Slide collar closed (8) (10). If regulator does not lock, repeat procedure. ♦

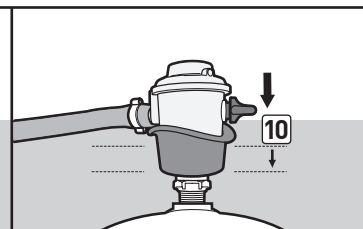
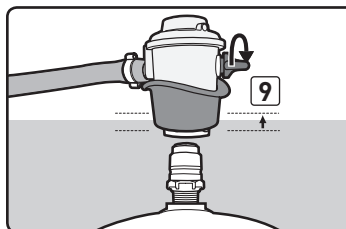
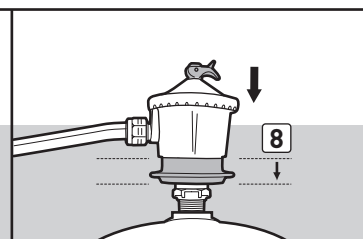
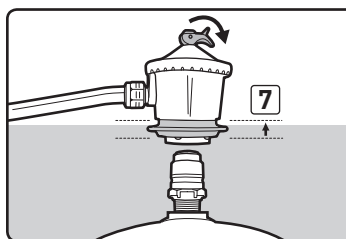
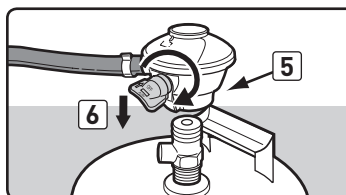
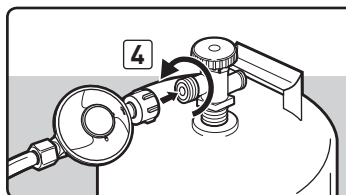
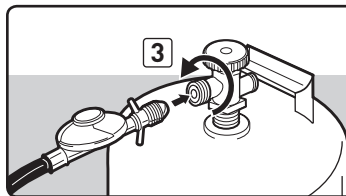
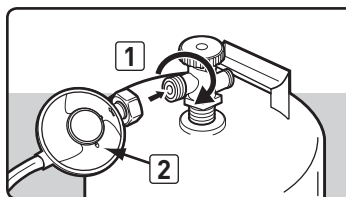

REPLACEMENT HOSE, REGULATOR AND VALVE ASSEMBLY

⚠ IMPORTANT NOTICE: We recommend that you replace the gas hose assembly on your gas grill every 5 years. Some countries may have requirements that the gas hose be replaced within less than 5 years, in which case that country's requirement would take precedence.

For replacement hose, regulator, and valve assemblies, contact the Customer Service Representative in your area using the contact information on our web site. Log on to www.weber.com.

GAS INSTRUCTIONS

LEAK-CHECK PREPARATION

⚠ WARNING: The gas connections of your SUMMIT gas grill have been factory-tested. We do, however, recommend that you leak-check all gas connections before operating your SUMMIT gas grill.

Remove Control Panel

Tools needed: Screwdriver, pliers, and towels.

- A) Remove burner control knobs (1).
- B) Open both doors. With a screwdriver, remove screws from the underside of control panel (2).
- C) Lift and remove battery housing located inside grill cabinet (3).
- D) Using needle-nose pliers, disconnect wire terminals from the top of battery housing (4). **Do not pull on the wires; remove them by pulling on the wire terminals.**
- E) Place towels on the tops of both door assemblies. **This will protect control panel and door assemblies from getting scratched on next step.**
- F) Tilt bottom of control panel forward. Lift slightly (5) and then rotate it face down to rest on tops of door assemblies. (Be careful not to break or disconnect wires for the control panel LEDs.)
- G) Carefully pull battery wires out from the inside of the grill cabinet (6).
- H) Fully open right door. Place control panel on floor, leaning against towel covering right door assembly (7).

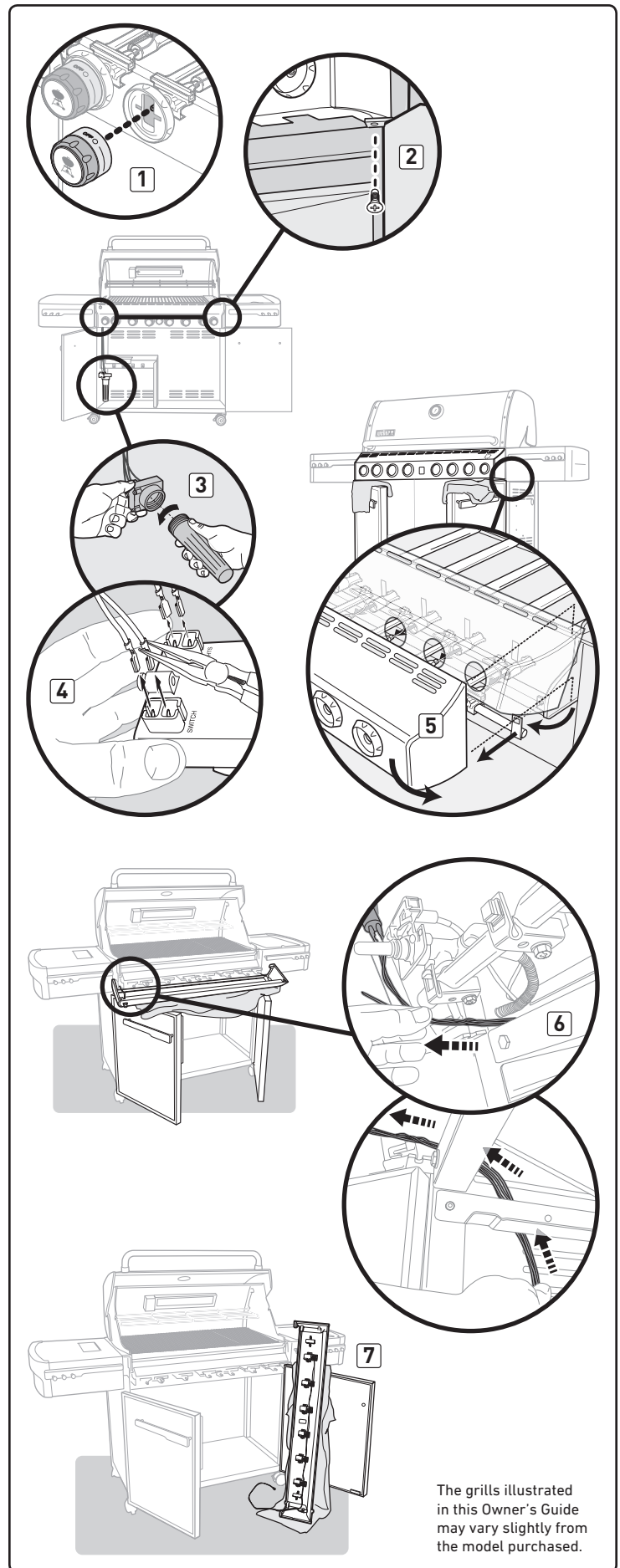

The grills illustrated in this Owner's Guide may vary slightly from the model purchased.

GAS INSTRUCTIONS

CHECK FOR GAS LEAKS

⚠ DANGER

Do not use an open flame to check for gas leaks. Be sure there are no sparks or open flames in the area while you check for leaks. Sparks or open flames will result in a fire or explosion, which can cause serious bodily injury or death and damage to property.

⚠ WARNING: You should check for gas leaks every time you disconnect and reconnect a gas fitting.

NOTE: All factory-made connections have been thoroughly checked for gas leaks. The burners have been flame-tested. As a safety precaution however, you should recheck all fittings for leaks before using your gas grill. Shipping and handling may loosen or damage a gas fitting.

⚠ WARNING: Perform these leak checks even if your grill was dealer- or shop-assembled.

NOTE: Since some leak-test solutions, including soap and water, may be slightly corrosive, all connections should be rinsed with water after checking for leaks.

If your grill has a side burner, make sure the side burner is off.

To perform leak checks: open cylinder valve by turning the cylinder valve hand-wheel anti-clockwise.

⚠ WARNING: Do not ignite burners when leak checking.

You will need: a soap-and-water solution, and a rag or brush to apply it.

- A) Mix soap and water.
- B) Turn on the cylinder valve using one of the appropriate options based on your cylinder and regulator type.
 - a) Turn cylinder valve anti-clockwise (1) (2) (3).
 - b) Turn regulator lever anti-clockwise to the on position (4).
 - c) Move regulator lever to the on position (5) (6).
- C) Check for leaks by wetting the fitting with the soap-and-water solution and watching for bubbles. If bubbles form, or if a bubble grows, there is a leak. If there is a leak, turn off the gas and tighten the fitting. Turn the gas back on and recheck with the soap-and-water solution. If leak does not stop, contact the Customer Service Representative in your area using the contact information on our website. Log onto www.weber.com.
- D) When leak checking is complete, turn gas supply off at the source and rinse connections with water.

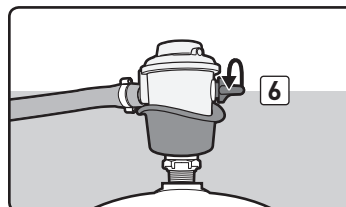
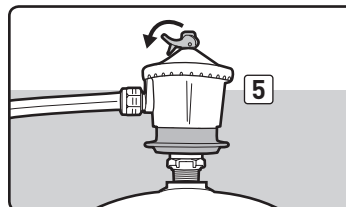
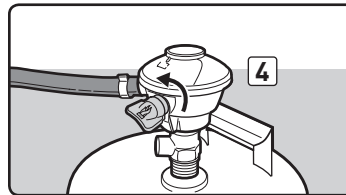
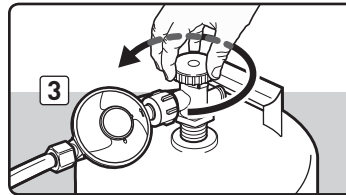
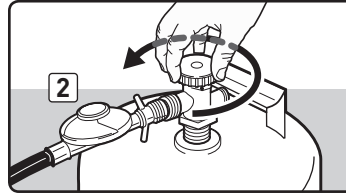
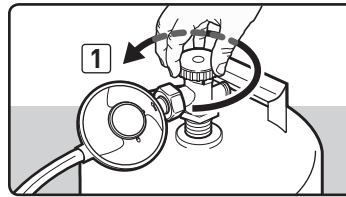

GAS INSTRUCTIONS

Check

- A) Main gas line-to-manifold connection (1).
- B) Rotisserie (I.R. Burner) gas line connection (2).
- C) Bulkhead and gas supply hose connection (3).

⚠ WARNING: If there is a leak at connection (1, 2, or 3), re-tighten the fitting with a spanner and recheck for leaks with soap-and-water solution. If a leak persists after re-tightening the fitting, turn off the gas. DO NOT OPERATE THE GRILL. Contact the Customer Service Representative in your area using the contact information on our web site. Log onto www.weber.com.

- D) Side burner hose to bulkhead connection (4).
- E) Side burner hose to quick disconnect connection, side burner valve and orifice connections (5).
- F) Hose-to-regulator connection (6).
- G) Regulator-to-cylinder connection (7).
- H) Valves-to-manifold connection (8).

⚠ WARNING: If there is a leak at connections (4, 5, 6, 7, or 8), turn off the gas. DO NOT OPERATE THE GRILL. Contact the Customer Service Representative in your area using the contact information on our web site. Log onto www.weber.com.

When leak checks are complete, turn gas supply off at the source and rinse connections with water.

Reinstall Control Panel

- A) To reinstall the control panel assembly, reverse steps for "Remove Control Panel" as previously described.
- B) Verify proper wire connections. Refer to "LIGHT FEATURES".

⚠ WARNING: Make sure that all parts are assembled and hardware is fully tightened before operating the grill. Your actions, if you fail to follow this product warning, may cause a fire, an explosion, or structural failure resulting in serious personal injury or death as well as damage to property. ♦

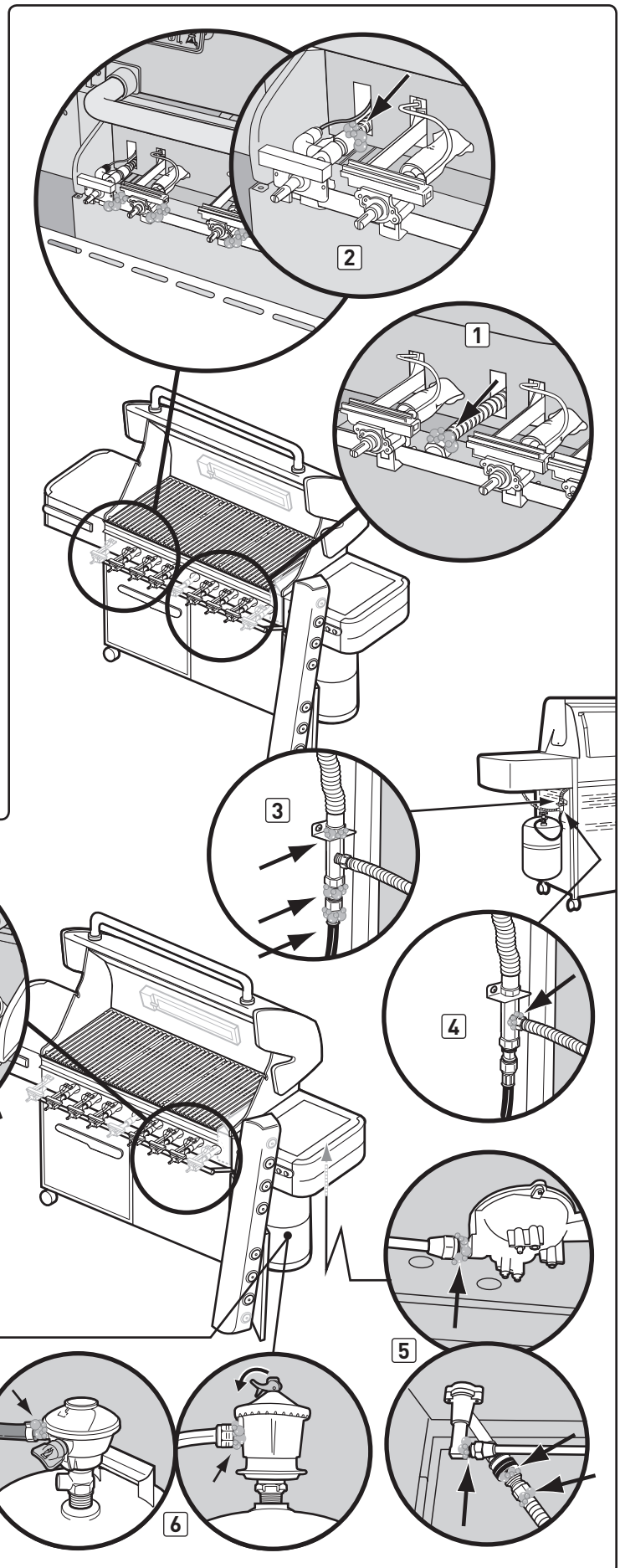

The grills illustrated in this Owner's Guide may vary slightly from the model purchased.

GAS INSTRUCTIONS

REFILLING THE LPG CYLINDER

We recommend that you refill the LPG cylinder before it is completely empty. To refill, take LPG cylinder to a "Gas Propane" dealer.

Removal of the gas supply cylinder:

- A) Shut off gas supply and disconnect hose and regulator assembly from the cylinder. Follow one of the specific regulator connection instructions illustrated based on your regulator type.
 - a) Unscrew regulator fitting from tank turning anticlockwise (1).
 - b) Unscrew regulator fitting from tank turning clockwise (2) (3).
 - c) Turn regulator lever clockwise (4) to the off position. Push in on regulator lever until it releases from tank (5).
 - d) Move regulator lever to the off position (6) (8). Slide the collar of the regulator up (7) (9) to disconnect from tank.
- B) Exchange empty cylinder for a full cylinder. ♦

RECONNECT THE LPG CYLINDER

Refer to "CONNECTING THE LPG CYLINDER." ♦

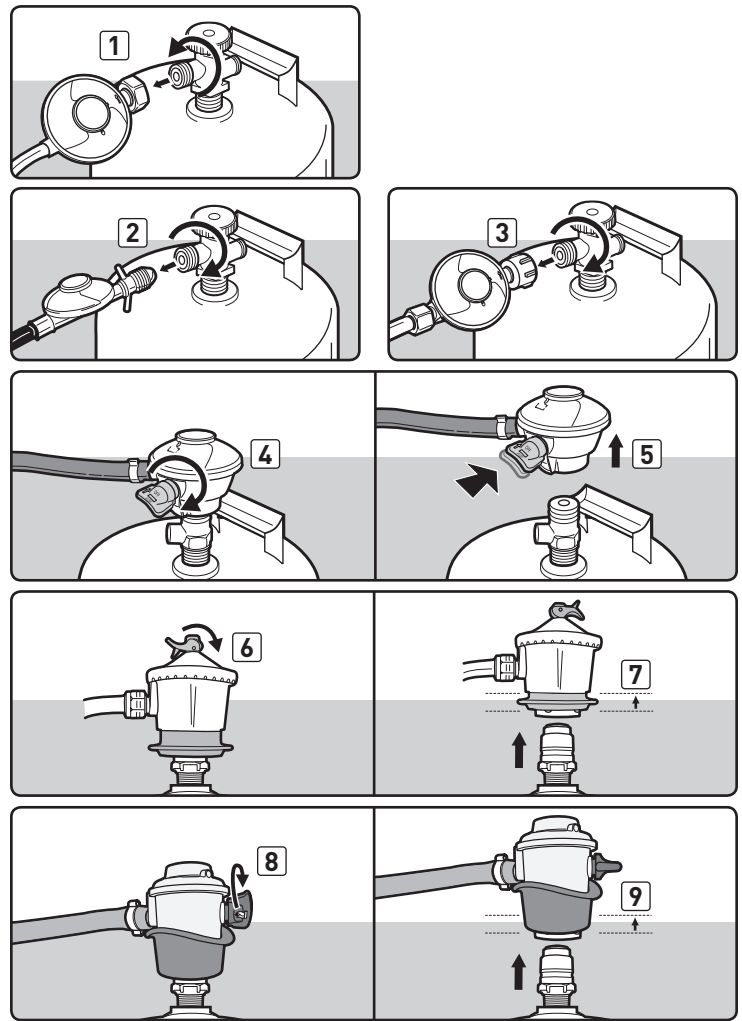

LIGHT FEATURES

GRILL LIGHT OPERATION

Press the AWAKE button to activate the grill light. The light has a 'tilt sensor' that will turn on the light if the grill lid is opened and turn off the light when the grill lid is closed. If the lid is left open or closed for more than 30 minutes, the grill light will deactivate. To turn the light back on, press the AWAKE button (1).

NOTE: The light does not turn OFF by pressing the AWAKE button. ♦

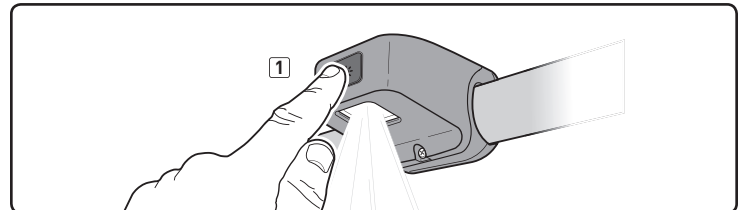

ILLUMINATED CONTROL KNOBS

Your gas grill comes with control knobs that light up; allowing you to fine-tune heat settings, even in low-light conditions.

Requires three "D" alkaline batteries. Do not mix old and new batteries or different types of batteries (standard, alkaline or rechargeable). Battery housing is located inside the cabinet on the left side.

To operate, activate power button. ♦

BATTERY HOUSING WIRING

1	BLACK WIRE	
2	GREEN WIRE	
3	RED WIRE	
4	RED WIRE	

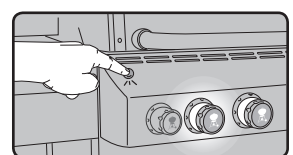
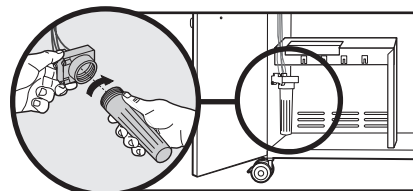

BEFORE USING THE GRILL

SLIDE-OUT GREASE TRAY AND DISPOSABLE DRIP PAN

Your grill was built with a grease collection system. Check the slide-out grease tray and disposable drip pan for grease build-up each time you use your grill.

Remove excess grease with a plastic spatula; see illustration. When necessary, wash the grease tray and drip pan with a soap and water solution, then rinse with clean water. Replace the disposable drip pan as needed.

- ⚠ **WARNING:** Always check the slide-out grease tray and disposable drip pan for grease build-up before using. Remove excess grease to avoid a grease fire. A grease fire can cause serious bodily injury or damage to property.
- ⚠ **CAUTION:** Do not line the slide-out grease tray with aluminum foil. ♦

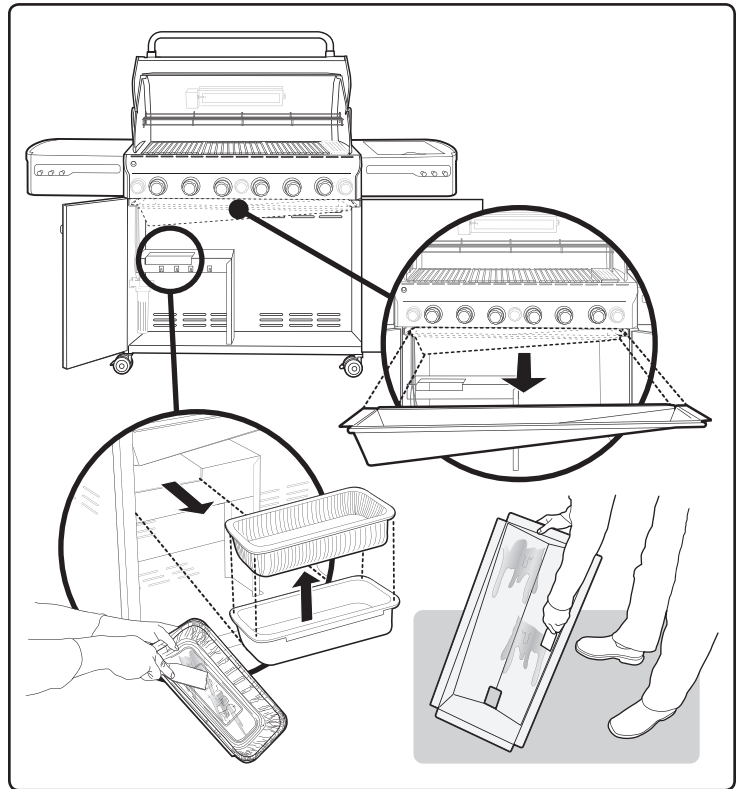

HOSE INSPECTION

The hose should be inspected for any signs of cracking.

- ⚠ **WARNING:** Always check hose before using grill for nicks, cracking, abrasions or cuts. If the hose is found to be damaged in any way, do not use the grill. Replace using only WEBER authorized replacement hose. Contact the Customer Service Representative in your area using the contact information on our web site. Log onto www.weber.com. ♦

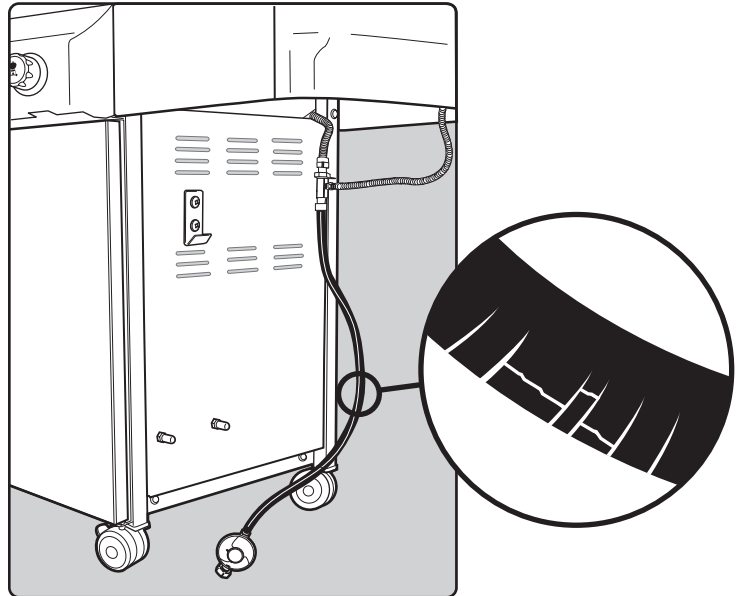

SNAP IGNITION OPERATION

⚠ Always open the lid before igniting the burners.

- A) Each control knob has its own igniter electrode built in. To create a spark you must push the control knob in **(1)** and turn to START/HI **(2)**.
- B) This action will generate gas flow and a spark to the burner lighting tube **(3)**. You will hear a "snap" from the igniter. You will also see a 3" (7 mm) - 5" (12 mm) orange flame coming from the burner lighting tube at the left side of the burner **(4)**.
- C) **Continue to hold the burner control knob in for two seconds after the "snap"**. This will allow gas to flow completely down the burner tube **(5)** and ensure ignition.
- D) Check that the burner is lit by looking through the cooking grates. You should see a flame. If burner does not light on first try, push control knob in and turn to OFF. Repeat lighting procedure a second time.

⚠ WARNING: If the burner still does not light, turn the burner control knob to OFF and wait five minutes to let the gas clear before you try again or try to light with a match. ♦

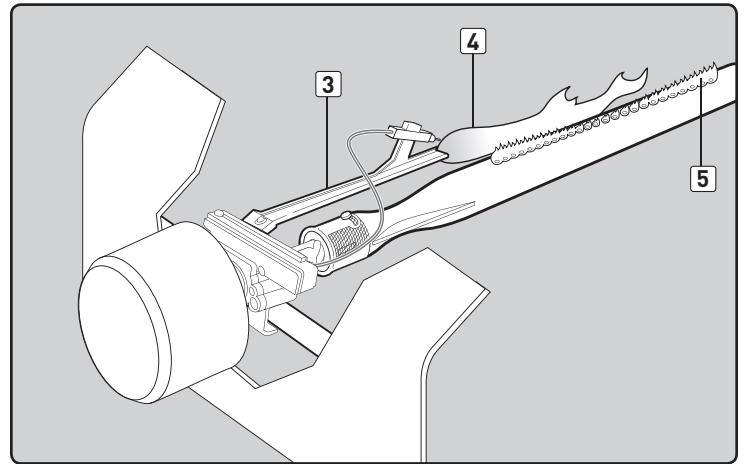
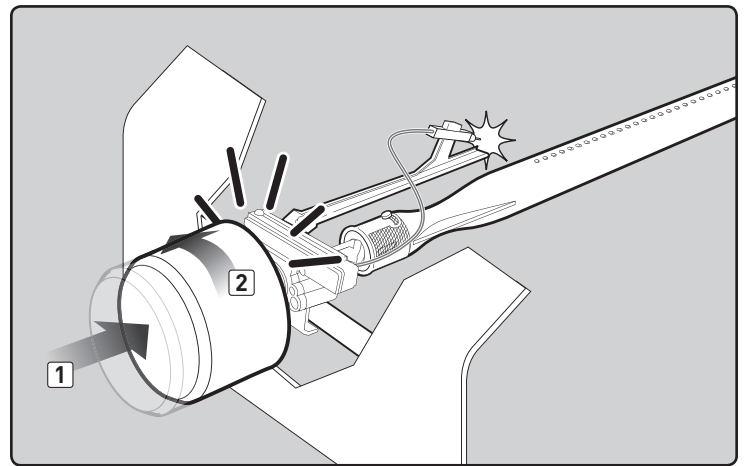

MAIN BURNER IGNITION & USAGE

MAIN BURNER IGNITION

⚠ DANGER

Failure to open the lid while igniting the grill's burners, or not waiting five minutes to allow the gas to clear if the grill does not light, may result in an explosive flare-up, which can cause serious bodily injury or death.

Main Burner Snap Ignition

NOTE: Each control knob snap igniter creates a spark from the igniter electrode to the burner lighting tube. You generate the energy for the spark by pushing in the control knob and turning to START/Hi. This will ignite each individual burner.

- A) Open the lid (1).
- B) Make sure all burner control knobs are turned off (2). (Push control knob in and turn clockwise to ensure that it is in the OFF position.)
- ⚠ **WARNING: The burner control knobs must be in the OFF position before turning on the liquid propane cylinder tank valve.**
- C) Turn on the cylinder valve using one of the appropriate options based on your cylinder and regulator type (3).
- ⚠ **WARNING: Do not lean over the open grill.**
- D) Push the control knob in and turn to START/Hi until you hear the igniter snap - continue to hold control knob in for two seconds. This action will spark the igniter, the burner lighting tube and then the main burner (4).
- E) Check that the burner is lit by looking through the cooking grates. You should see a flame (5). If burner does not light at the first attempt, push control knob in and turn to OFF. Repeat lighting procedure a second time.
- ⚠ **WARNING: If the burner still does not light, turn the burner control knob to OFF and wait five minutes to let the gas clear before you try again or try to light with a match. ♦**

TO EXTINGUISH

Push in and turn each burner control knob clockwise to OFF position. Turn gas supply off at the source. ♦

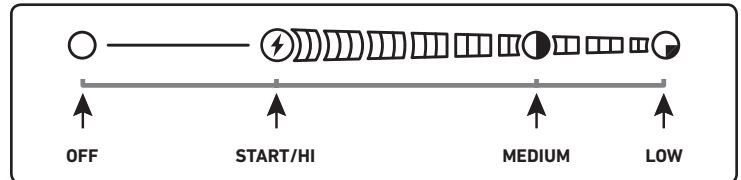
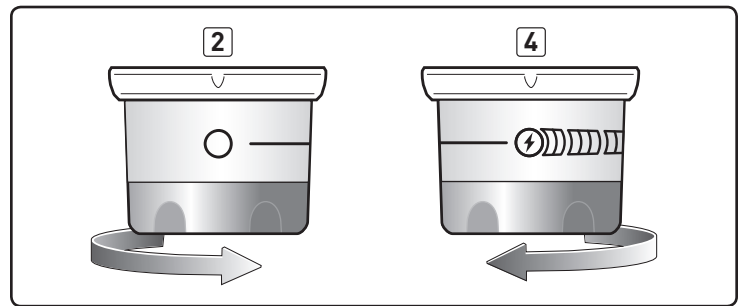
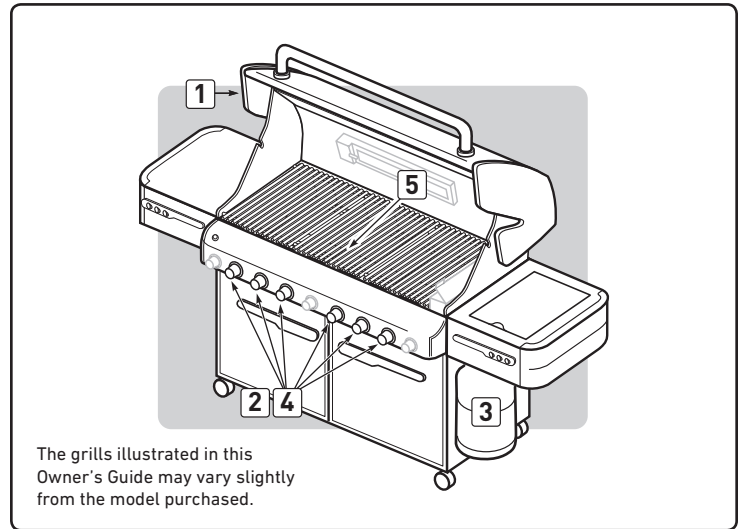

MAIN BURNER IGNITION & USAGE

MAIN BURNER MANUAL IGNITION

⚠ DANGER

Failure to open the lid while igniting the grill's burners, or not waiting five minutes to allow the gas to clear if the grill does not light, may result in an explosive flare-up, which can cause serious bodily injury or death.

- A) Open the lid (1).
- B) Make sure all burner control knobs are turned off (2). (Push each knob in and turn clockwise to ensure they are in the OFF position.)
- ⚠ WARNING: The burner control knobs must be in the OFF position before turning on the liquid propane cylinder valve.**
- C) Turn on the cylinder valve using one of the appropriate options based on your cylinder and regulator type (3).
- D) Put match in the match holder and strike match.
- ⚠ WARNING: Do not lean over open grill.**
- E) Insert match holder and lit match down through cooking grates and FLAVORIZER BARS to ignite the selected burner (4).
- F) Push the control knob in and turn to START/HI (5).
- G) Check that the burner is lit by looking through the cooking grates. You should see a flame (6).
- ⚠ WARNING: If the burner does not light, turn the burner control knob to OFF and wait five minutes to let the gas clear before you try again. ♦**

TO EXTINGUISH

Push in and turn each burner control knob clockwise to OFF position. Turn gas supply off at the source. ♦

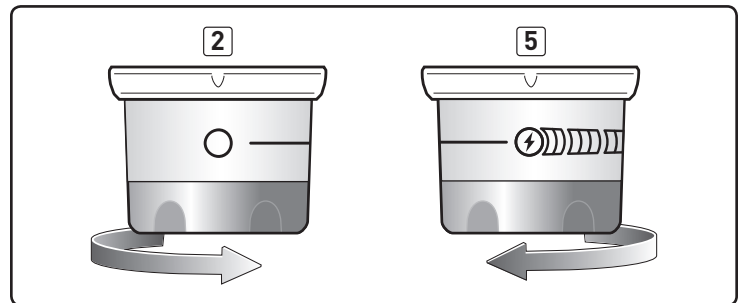
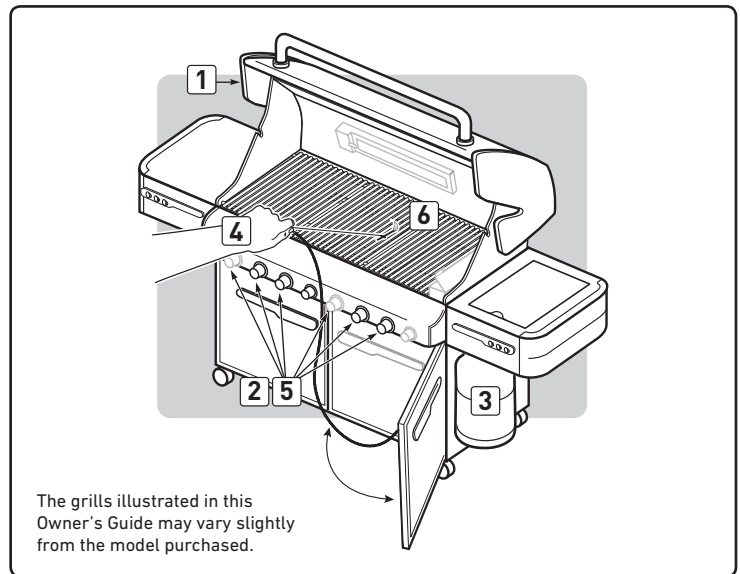

GRILLING TIPS & HELPFUL HINTS

- Always preheat the grill before cooking. Set all burners on HI heat and close lid; heat for 10 minutes, or until thermometer registers 500°-550°F (260°-288°C).
- Sear meats and cook with the lid down for perfectly grilled food every time.
- Grilling times in recipes are based on 70°F (20°C) weather and little or no wind. Allow more cooking time on cold or windy days, or at higher altitudes. Allow less cooking time in extremely hot weather.
- Grilling times can vary because of the weather, or the amount, size and shape of the food being grilled.
- The temperature of your gas grill may run hotter than normal for the first few uses.
- Grilling conditions may require the adjustment of the burner controls to attain the correct cooking temperatures.
- In general, large cuts of meat will require more cooking time per pound than small cuts of meat. Foods on a crowded cooking grate will require more cooking time than just a few foods. Foods grilled in containers, such as baked beans, will require more time if grilled in a deep casserole rather than a shallow baking pan.
- Trim excess fat from steaks, chops and roasts, leaving no more than a scant ¼ inch (6.4mm) of fat. Less fat makes cleanup easier, and is a virtual guarantee against unwanted flare-ups.
- Foods placed on the cooking grate directly above burners may require turning or moving to a less hot area.
- Use tongs rather than a fork for turning and handling meats to avoid losing natural juices. Use two spatulas for handling large whole fish.
- If an unwanted flare-up should occur, turn all burners off and move food to another area of the cooking grate. Any flames will quickly subside. After flames subside, relight the grill. NEVER USE WATER TO EXTINGUISH FLAMES ON A GAS GRILL.
- Some foods, such as a casserole or thin fish fillets, will require a container for grilling. Disposable foil pans are very convenient, but any metal pan with ovenproof handles can also be used.
- Always be sure the grease tray and catch pan are clean and free from debris.
- Do not line the slide-out grease tray with foil. This could prevent the grease from flowing into the catch pan.
- Using a timer will help to alert you when “well done” is about to become “overdone.” ♦

PREHEATING

Your WEBER gas grill is an energy-efficient appliance. It operates at an economical low BTU rate. Preheating the grill before grilling is important. Light your grill according to the instructions in this Owner's Manual. To preheat: after lighting turn all burners to START/HI, close the lid, and heat until the temperature reaches between 500°F and 550°F (260° and 288° C), the recommended broiling temperature. This will take 10 to 15 minutes depending on conditions such as air temperature and wind.

You can adjust the individual burners as desired. The control settings are OFF, START/HI, MEDIUM, or LOW.

NOTE: Cooking conditions, such as wind and weather, may require adjustment of burner controls to obtain the correct cooking temperatures.

NOTE: If grill loses heat while cooking refer to the troubleshooting section of this manual.

⚠ WARNING: Do not move the WEBER gas grill when operating or while grill is hot.

If burners go out during cooking, turn all burner knobs off and wait five minutes before relighting. ♦

COVERED COOKING

All grilling is done with the lid down to provide uniform, evenly circulated heat. With the lid closed, the gas grill cooks much like a convection oven. The thermometer in the lid indicates the cooking temperature inside the grill. All preheating and grilling is done with the lid down. No peeking — heat is lost every time you lift the lid. ♦

DRIPPINGS AND GREASE

The FLAVORIZER BARS are designed to “smoke” the correct amount of drippings for flavour some cooking. Excess drippings and grease will accumulate in the catch pan under the slide-out grease tray. Disposable foil drip pans are available that fit the catch pan.

⚠ WARNING: Check the slide-out grease tray and catch pan for grease build-up before each use. Remove excess grease to avoid a grease fire in the slide-out grease tray. ♦

FLAVORIZER SYSTEM

When meat juices drip from the food onto the specially angled FLAVORIZER BARS, they create smoke that gives foods an irresistible grilled flavour. Thanks to the unique design of the burners, FLAVORIZER BARS and the flexible temperature controls, uncontrolled flare-ups are virtually eliminated, because YOU control the flames. Because of the special design of the FLAVORIZER BARS and burners, excess fats are directed through the slide-out grease tray into the grease catch pan. ♦

SEAR STATION

Your WEBER gas grill may include a sear burner for searing thin meats and fish. The SEAR STATION burner has an ON or OFF control setting that works with the two adjacent main burners. With the sear and adjacent burners you can effectively sear meats while using other cooking areas for cooking with moderate heat (refer to “SEAR STATION IGNITION & USAGE”). ♦

COOKING METHODS

The most important thing to know about grilling is which cooking method to use for a specific food, Direct or Indirect. The difference is simple: place the food directly over the fire, or arrange the fire on either side of it. Using the right method is the shortest route to great results—and the best way to ensure food is safely cooked through. ♦

DIRECT COOKING

The Direct Method, similar to grilling, means the food is cooked directly over the heat source. For even cooking, food should be turned once halfway through the grilling time.

Use the Direct method for foods that take less than 25 minutes to cook: steaks, chops, kebabs, sausages, vegetables, and more.

Direct cooking is also necessary to sear meats. Searing creates that wonderful crisp, caramelized texture where the food hits the grate. It also adds great colour and flavour to the entire surface. Steaks, chops, chicken breasts, and larger cuts of meat all benefit from searing.

To sear meats, place them over Direct High heat for 2 to 5 minutes per side. Smaller pieces require less searing time. Usually after searing you finish cooking the food at a lower temperature. You can finish cooking fast-cooking foods by the Direct method; use the Indirect method for longer-cooking foods.

To set up your gas grill for Direct cooking, preheat the grill with all burners on HI. Place food on the cooking grate, and then adjust all burners to the temperature noted in the recipe. Close the lid of the grill and lift it only to turn food or to test for doneness at the end of the recommended cooking time. ♦

INDIRECT COOKING

The Indirect Method is similar to roasting, but with the added benefits of that grilled texture, flavour, and appearance you can't get from an oven. To set up for Indirect cooking, gas burners are lit on either side of the food but not directly beneath it. Heat rises, reflects off the lid and inside surfaces of the grill, and circulates to slowly cook the food evenly on all sides, much like a convection oven, so there's no need to turn the food.

Use the Indirect method for foods that require 25 minutes or more of grilling time or that are so delicate that direct exposure to the flame would dry them out or scorch them. Examples include roasts, ribs, whole chickens, turkeys, and other large cuts of meat, as well as delicate fish fillets.

To set up your gas grill for Indirect cooking, preheat the grill with all burners on HI. Then adjust the burners on each side of the food to the temperature noted in the recipe and turn off the burner(s) directly below the food. For best results, place roasts, poultry, or large cuts of meat on a roasting rack set inside a disposable heavy-gauge foil pan. For longer cooking times, add water to the foil pan to keep drippings from burning. The drippings can be used to make gravies or sauces. ♦

6 BURNER

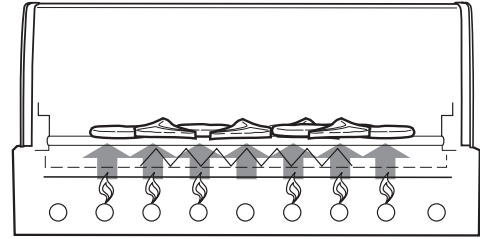

1 2 3 4 5 6
H H H H H H

DIRECT METHOD

Food is placed on the area of the cooking grates directly over the lit burners.

6 BURNER

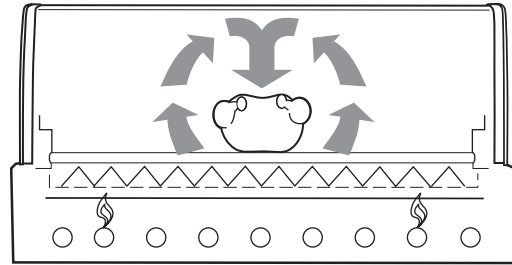

1 2 3 4 5 6
M M

INDIRECT METHOD

Food is placed on the area of the cooking grates between the lit burners.

SIDE BURNER IGNITION & USAGE

SIDE BURNER IGNITION

⚠ DANGER

Failure to open the lid while igniting the side burner, or not waiting five minutes to allow the gas to clear if the side burner does not light, may result in an explosive flare-up, which can cause serious bodily injury or death.

- A) Open the side burner lid (1).
- B) Check that the side burner valve is turned off (Push control knob in and turn clockwise to ensure that it is in the OFF position.) Turn all burners not being used to the OFF position (push in and turn clockwise) (2).
- C) Turn on the cylinder valve using one of the appropriate options based on your cylinder and regulator type (3).
- D) Push down and turn the side burner control valve to START/HI (4).
- E) Press the igniter button several times so it clicks each time until you see a flame (5).

⚠ **CAUTION:** Side burner flame may be difficult to see on a bright sunny day.

⚠ **WARNING:** If the side burner does not light in five seconds:

- a) Turn off the side burner control valve, main burners and gas supply at source.
- b) Wait five minutes to let the gas clear before you try again, or try lighting with a match (refer to "SIDE BURNER MANUAL IGNITION"). ♦

TO EXTINGUISH

Push down and turn side burner control knob to the OFF position. Be sure the burner is off and cool before closing the side burner lid. ♦

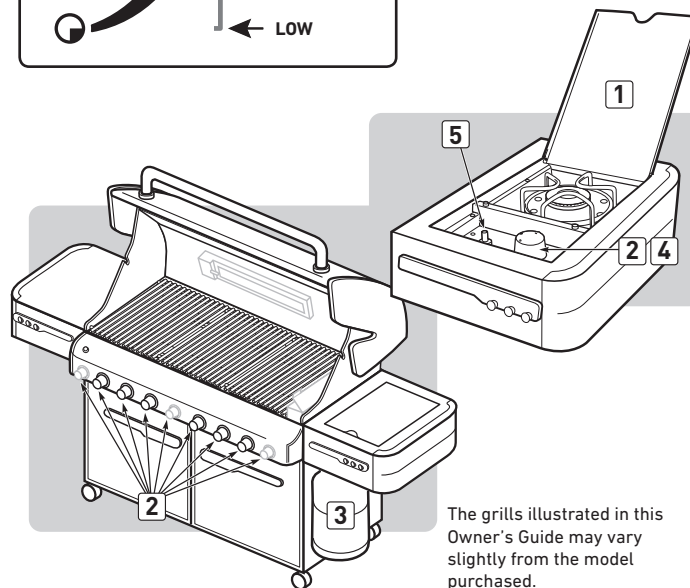
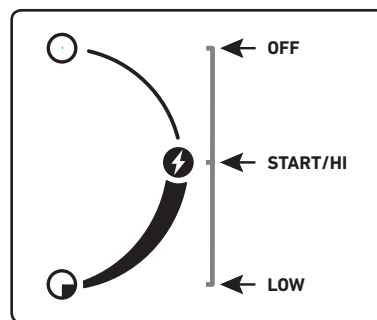

The grills illustrated in this Owner's Guide may vary slightly from the model purchased.

SIDE BURNER MANUAL IGNITION

⚠ DANGER

Failure to open the lid while igniting the side burner, or not waiting five minutes to allow the gas to clear if the side burner does not light, may result in an explosive flare-up that can cause serious bodily injury or death.

- A) Open the side burner lid (1).
- B) Check that the side burner valve is turned off (2) (Push control knob in and turn clockwise to ensure that it is in the OFF position). Turn all burners not being used to the OFF position (push in and turn clockwise).
- C) Turn on the cylinder valve using one of the appropriate options based on your cylinder and regulator type (3).
- D) Put match in a match holder and strike match.
- E) Hold match holder and lit match by either side of the side burner (4).
- F) Push down and turn the side burner control valve to START/HI (5).

⚠ **CAUTION:** Side burner flame may be difficult to see on a bright sunny day.

⚠ **WARNING:** If the side burner does not light in five seconds:

- a) Turn off the side burner control valve, main burners and gas supply at source.
- b) Wait five minutes to let the gas clear before you try again. ♦

TO EXTINGUISH

Push down and turn side burner control knob to the OFF position. Be sure the burner is off and cool before closing the side burner lid. ♦

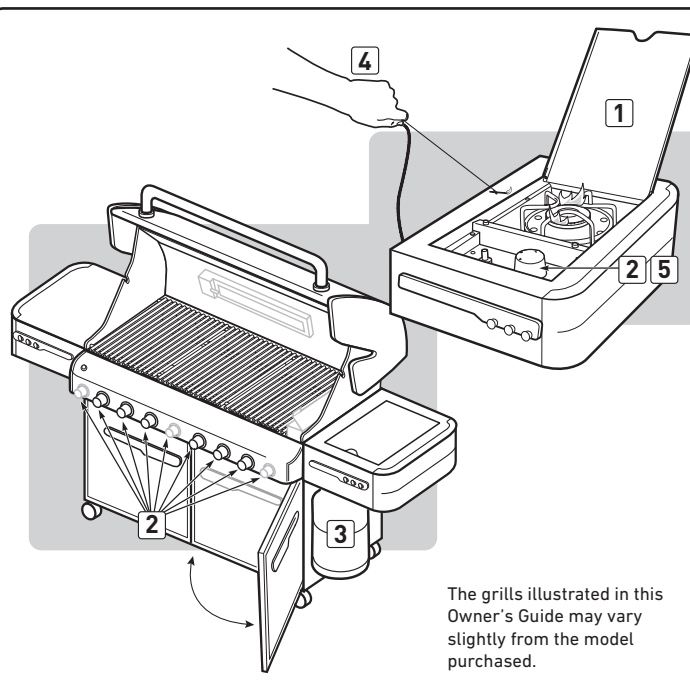

The grills illustrated in this Owner's Guide may vary slightly from the model purchased.

SEAR STATION IGNITION & USAGE

SEAR STATION BURNER IGNITION

⚠ DANGER

Failure to open the lid while igniting the grill's burners, or not waiting five minutes to allow the gas to clear if the grill does not light, may result in an explosive flare-up, which can cause serious bodily injury or death.

The SEAR STATION burner has an ON or OFF control setting. To ignite the SEAR STATION burner you must first ignite the two adjacent main burners.

Adjacent Main Burner Snap Ignition

NOTE: Each main burner control knob snap igniter creates a spark from the igniter electrode to the burner lighting tube. You generate the energy for the spark by pushing in the control knob and turning to START/Hi. This will ignite each individual burner.

⚠ **WARNING: Always check hose before using grill for nicks, cracking, abrasions or cuts. If the hose is found to be damaged in any way, do not use the grill. Replace using only WEBER authorised replacement hose. Contact the Customer Service Representative in your area using the contact information on our web site.**

Log onto www.weber.com.

- A) Open the lid (1).
- B) Make sure all burner control knobs are turned off (2). (Push control knob in and turn clockwise to ensure that it is in the OFF position.)
- C) Turn on the cylinder valve using one of the appropriate options based on your cylinder and regulator type (3).

⚠ **WARNING: Do not lean over the open grill.**

- D) Ignite each adjacent SEAR STATION main burner (4). Push the control knob in and turn to START/Hi until you hear the igniter snap - continue to hold control knob in for two seconds. This action will spark the igniter, the burner lighting tube and then the main burner.
- E) Check that the burner is lit by looking through the cooking grates (5). You should see a flame. If burner does not light on first try, push control knob in and turn to OFF. Repeat lighting procedure a second time.

SEAR STATION Burner Lighting: Ignition by an adjacent ignited main burner

- F) Turn SEAR STATION burner control knob to the ON position (6).
- G) Verify burner ignition by visual inspection of a flame (7).

⚠ **WARNING: If ignition does not occur within five seconds, turn burner control OFF, wait five minutes, and repeat steps F & G, or refer to "SEAR STATION BURNER MANUAL IGNITION" instructions.**

⚠ **WARNING: If the burner still does not light, turn the burner control knob to OFF and wait five minutes to let the gas clear before you try again or try to light with a match.**

Note: Refer to "MAINTENANCE" for burner removal and cleaning procedure. ♦

TO EXTINGUISH

Push in and turn each burner control knob clockwise to OFF position. Turn gas supply off at the source. ♦

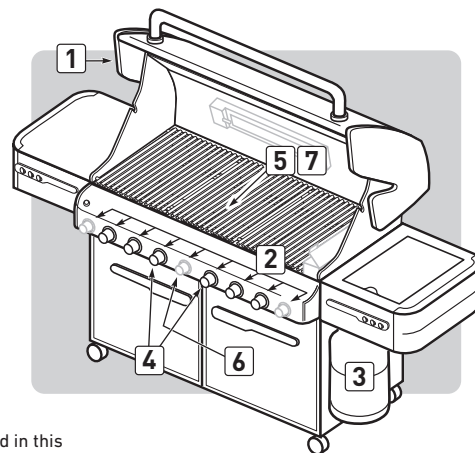

The grills illustrated in this Owner's Guide may vary slightly from the model purchased.

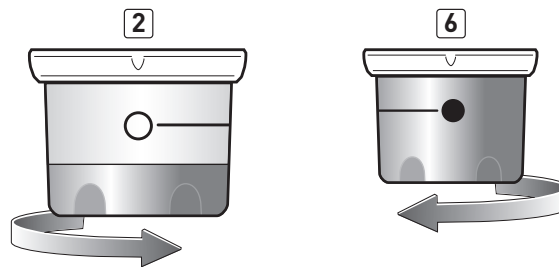

SEAR STATION IGNITION & USAGE

SEAR STATION BURNER MANUAL IGNITION

⚠ DANGER

Failure to open the lid while igniting the grill's burners, or not waiting five minutes to allow the gas to clear if the grill does not light, may result in an explosive flare-up, which can cause serious bodily injury or death.

The SEAR STATION burner has an ON or OFF control setting. To ignite the SEAR STATION burner you must first ignite the two adjacent main burners.

Adjacent Main Burner Snap Ignition

NOTE: Each main burner control knob snap igniter creates a spark from the igniter electrode to the burner lighting tube. You generate the energy for the spark by pushing in the control knob and turning to START/Hi. This will ignite each individual burner.

- Open the lid (1).
 - Verify each adjacent SEAR STATION main burner is lit by visual inspection of a flame (2).
 - Put match in the match holder and strike match.
- ⚠ WARNING: Do not lean over open grill.**
- Insert match holder and lit match down through cooking grates and FLAVORIZER BARS to ignite the SEAR STATION burner (3).
 - Push the SEAR STATION control knob in and turn to the ON position (4).

⚠ WARNING: If the burner does not light, turn the burner control knob to OFF and wait five minutes to let the gas clear before you try again.

Note: Refer to "MAINTENANCE" for burner removal and cleaning procedure. ♦

TO EXTINGUISH

Depress and turn each burner control knob clockwise to OFF position. Turn gas supply off at the source. ♦

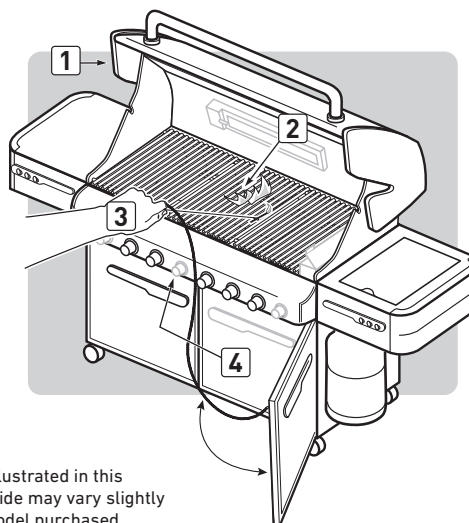

The grills illustrated in this Owner's Guide may vary slightly from the model purchased.

6 BURNER

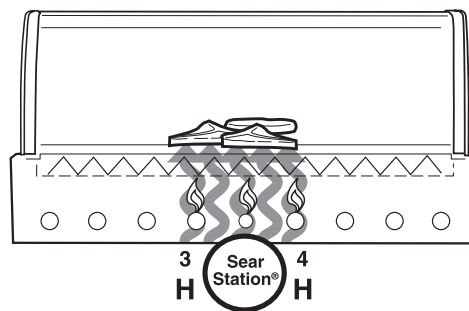

SEAR METHOD

Food is placed in the area of intense heat between the lit burners.

USING THE SEAR STATION

Your gas grill includes a sear burner for searing meats such as steak, poultry cuts, fish, and chops.

Searing is a direct grilling technique, which browns the surface of the food at a high temperature. By searing or browning both sides of the meat you will create a more desirable flavour by caramelizing the food surface. Searing will also enhance appearance of the meat with sear marks from the cooking grates. This along with the contrast of textures and flavours can make food more interesting to the palate.

The SEAR STATION burner has an ON or OFF control setting that works with the two adjacent main burners. With the sear and adjacent burners you can effectively sear meats while using other cooking areas for grilling with moderate heat.

Before searing you should turn all of the main burners on HI for 15 minutes to preheat the grill. *Note: Always grill with the lid closed to allow for maximum heat and to avoid flare-ups.*

Once the grill is preheated, turn the outer burners off or down to low. Leave the centre two burners on HI and ignite the SEAR STATION burner.

Place the meat directly over the SEAR STATION. You will sear each side anywhere from 1 to 4 minutes, depending on the type of meat and thickness. You may turn the food a quarter turn to make crossing sear marks (1) before you sear the other side in the same manner.

Once you have finished searing, you can finish grilling by moving the meat to a more moderate heat over the outside burners to achieve the desired doneness.

As you gain experience in using your SEAR STATION, we encourage you to experiment with different searing times to find results that work best for your taste. ♦

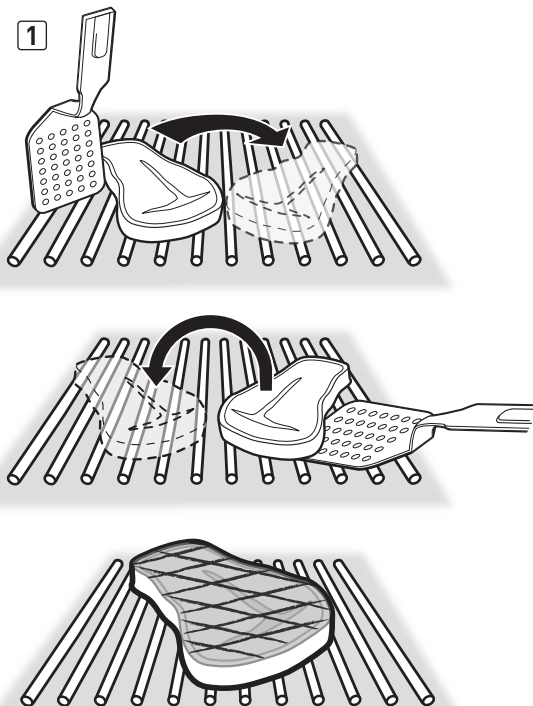

SMOKER BURNER IGNITION & USAGE

SMOKER BURNER IGNITION

⚠ DANGER

Failure to open the lid while igniting the grill, or not waiting five minutes to allow the gas to clear if the grill does not light, may result in an explosive flare-up, which can cause serious bodily injury or death.

Smoker Burner Snap Ignition

NOTE: The control knob snap igniter creates a spark from the igniter electrode to the burner lighting tube. You generate the energy for the spark by pushing in the control knob and turning to START/Hi. This will ignite the smoker burner.

⚠ **WARNING: Always check hose before using grill for nicks, cracking, abrasions or cuts. If the hose is found to be damaged in any way, do not use the grill. Replace using only WEBER authorised replacement hose. Contact the Customer Service Representative in your area using the contact information on our web site.**

Log onto www.weber.com.

- A) Open the grill lid (1).
- B) Open smoker box lid (2).
- C) Fill smoker with water-soaked wood chunks or chips (3).
- D) Make sure that all burner control knobs not being used are turned to OFF (4). (Push control knob in and turn clockwise to ensure that it is in the OFF position).
- ⚠ **WARNING: The burner control knobs must be in the OFF position before turning on the liquid propane cylinder tank valve.**
- E) Turn on the cylinder valve using one of the appropriate options based on your cylinder and regulator type (5).
- ⚠ **WARNING: Do not lean over the open grill while lighting.**
- F) Push the control knob in and turn to START/Hi until you hear the igniter snap (6), continue to hold control knob in for two seconds. This action will spark the igniter, the burner lighting tube and then the main burner.
- G) Check that the burner is lit by looking through the cooking grates (7). You should see a flame. If burner does not light at the first attempt, push control knob in and turn to OFF. Repeat lighting procedure a second time.

⚠ DANGER

If the smoker burner still does not light, turn the burner control knob to OFF and wait five minutes to let the gas clear before you try again, or try lighting with a match (refer to "SMOKER BURNER MANUAL IGNITION").

- H) Close smoker cover after wood starts to smoulder and turn control knob to LOW (8).

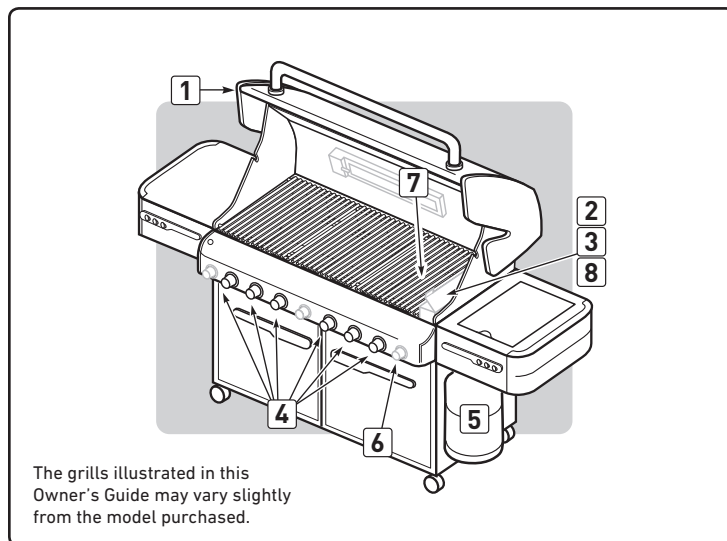

The grills illustrated in this Owner's Guide may vary slightly from the model purchased.

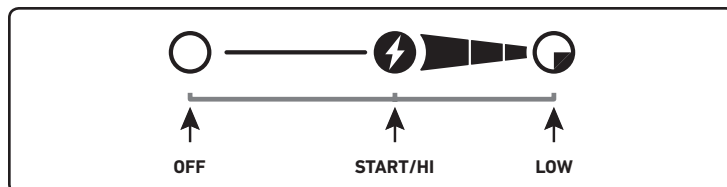
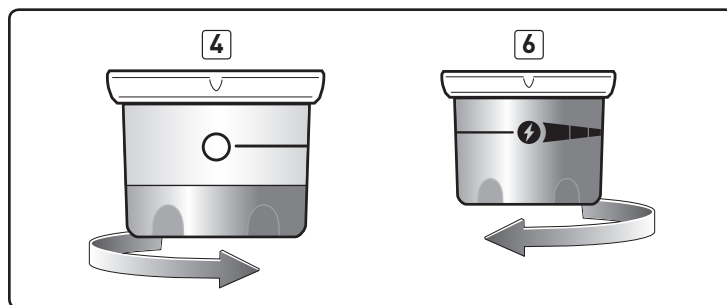

TO EXTINGUISH

Push in and turn each burner control knob clockwise to OFF position. Turn gas supply off at the source. ♦

SMOKER BURNER IGNITION & USAGE

SMOKER BURNER MANUAL IGNITION

⚠ WARNING: Always check hose before using grill for nicks, cracking, abrasions or cuts. If the hose is found to be damaged in any way, do not use the grill. Replace using only WEBER authorised replacement hose. Contact the Customer Service Representative in your area using the contact information on our web site.

Log onto www.weber.com.

A) Open the lid (1).

⚠ DANGER

Failure to open the lid while igniting the grill, or not waiting five minutes to allow the gas to clear if the grill does not light, may result in an explosive flare-up, which can cause serious bodily injury or death.

B) Open smoker box lid (2).

C) Fill smoker with water-soaked wood chunks or chips (3).

D) Make sure that all burner control knobs not being used are turned to OFF (4). (Push control knob in and turn clockwise to ensure that it is in the OFF position).

⚠ WARNING: The burner control knobs must be in the OFF position before turning on the liquid propane cylinder tank valve.

E) Turn on the cylinder valve using one of the appropriate options based on your cylinder and regulator type (5).

F) Put a match in the match holder and strike the match.

G) Insert match holder and lit match down through cooking grates and FLAVORIZER BARS to ignite smoker burner (6).

⚠ WARNING: Do not lean over the open grill while lighting.

H) Push smoker burner control knob in and turn to START/HI (7).

I) Check that the burner is lit by looking down through the cooking grate (8).

⚠ DANGER

If the smoker burner does not light, turn the burner control knob to OFF and wait five minutes to let the gas clear before you try again.

J) Close smoker cover after wood starts to smoulder and turn control knob to LOW (9).

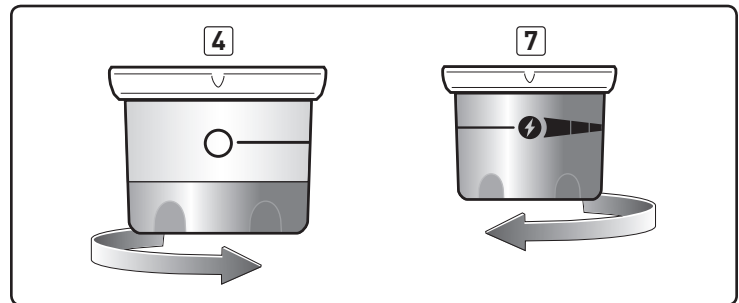
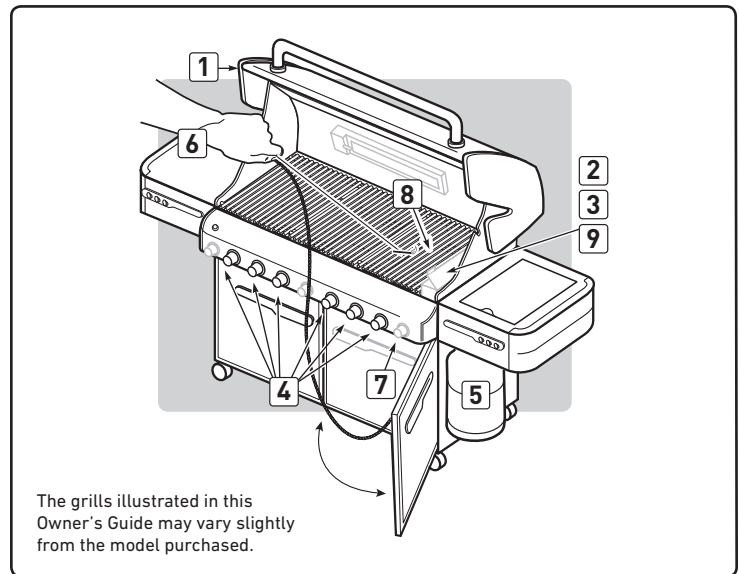

TO EXTINGUISH

Push in and turn each burner control knob clockwise to OFF position. Turn gas supply off at the source. ♦

SMOKER BURNER IGNITION & USAGE

USING THE SMOKER

The smoker uses presoaked wood chips. For best results with faster cooking foods such as steaks, burgers and chops, etc., we recommend using finer wood chips because they ignite and create smoke faster. For longer cooking foods such as roasts, chicken and turkeys, etc., we recommend using larger wood chunks because they ignite slowly and provide smoke for a longer period of time. As you gain experience in using your smoker, we encourage you to experiment with different combinations of wood chips and chunks to find the smoke flavour that best suits your taste.

As a starting point, soak wood chips in water for at least 20 minutes before using. (Wet wood will produce more smoke flavour.) Place a handful of wood chips or a few larger chunks in the bottom of the smoker body (1). As you gain experience in smoking, increase or decrease the amount of wood to suit your taste.

NOTE: Always grill with the lid closed to allow the smoke to fully penetrate the food. Light the smoker burner by following the instructions for "SMOKER BURNER IGNITION". After wood starts to smoulder turn control knob to LOW.

Smoke will start in approximately 10 minutes and last as long as 45 minutes. If you require more smoke flavour, refill the smoker with wood chips and/or chunks. Keep the lid of the grill closed while cooking.

NOTE: After refilling the smoker, smoke will take about 10 to 15 minutes to start again. The smoker may be used to enhance meat, poultry and fish recipes. Cook with the lid down according to the times indicated in charts or recipes.

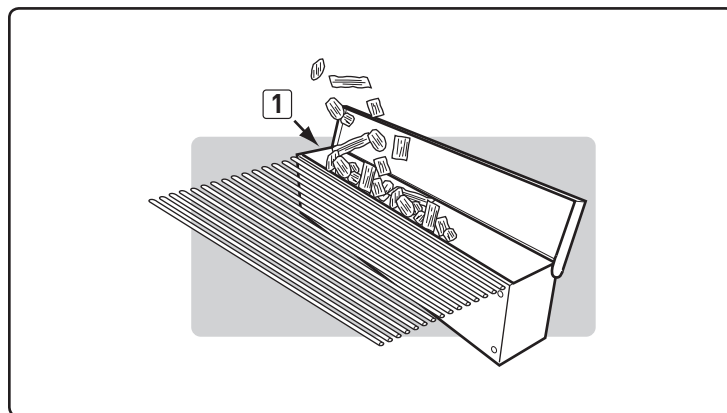

⚠ DANGER

Do not use any flammable fluid in the smoker to ignite the wood. This will cause serious bodily injury. ♦

CLEANING THE SMOKER

Each time before using, empty the smoker of ash to allow proper air flow.

NOTE: Smoking will leave a "smoke" residue on the surface of the smoker. This residue cannot be removed and will not affect the function of the smoker. To a lesser degree a "smoke" residue will accumulate on the inside of your gas grill. This residue need not be removed and will not adversely affect the function of your gas grill. ♦

ROTISSERIE BURNER IGNITION & USAGE

ROTISSERIE BURNER IGNITION

Rotisserie Burner Snap Ignition

NOTE: Each control knob snap igniter creates a spark from the igniter electrode to the burner lighting tube. You generate the energy for the spark by pushing in the control knob and turning to START/Hi. This will ignite each individual burner.

⚠ ATTENTION: READ BEFORE LIGHTING ROTISSERIE BURNER

After a period of non-use, before lighting the Rotisserie Burner, a few seconds must pass for the gas supply line to fill.

When using the snap igniter you will see a flash of flames moving from left to right across the Rotisserie Burner surface, the Rotisserie Burner is not lit until the entire ceramic surface is aflame.

At this point, start a count of twenty seconds before releasing the Rotisserie Burner control knob.

The Rotisserie Burner surface will glow red once the burner is fully ignited.

⚠ DANGER

Failure to open the lid while igniting the grill, or not waiting five minutes to allow the gas to clear if the grill does not light, may result in an explosive flare-up, which can cause serious bodily injury or death.

- ⚠ **CAUTION:** The Rotisserie Burner flame may be difficult to see on a bright sunny day.
- ⚠ **WARNING:** Always check hose before using grill for nicks, cracking, abrasions or cuts. If the hose is found to be damaged in any way, do not use the grill. Replace using only a WEBER authorised replacement hose. Contact the Customer Service Representative in your area using the contact information on our web site.
Log onto www.weber.com.

- A) Open the lid (1).
- B) Remove the warming rack and the cooking grates from the cookbox (2).
- C) Make sure all burner control knobs are turned off (3). (Push control knob in and turn clockwise to ensure that it is in the OFF position.)
- ⚠ **WARNING:** The burner control knobs must be in the OFF position before turning on the liquid propane cylinder tank valve.
- D) Turn on the cylinder valve using one of the appropriate options based on your cylinder and regulator type (4).
- ⚠ **WARNING:** Do not lean over the open grill.
- E) Push the control knob in and turn to START/Hi. This action will spark the igniter and light the Rotisserie Burner. Continue to use the snap igniter until the Rotisserie Burner has ignited. Continue to hold the control knob down for twenty seconds after the burner has ignited. Release the control knob (5).
- F) Check that the burner is lit by looking for the rotisserie burner to glow red (6).
- ⚠ **WARNING:** If the rotisserie burner does not light, turn the burner control knob to OFF and wait five minutes to let the gas clear before you try again or try to light with a match.

NOTE: When using the rotisserie with the lid closed, only light two of the main burners on each side of the food (refer to COOKING METHODS-INDIRECT COOKING). Check your food periodically to prevent overcooking on the outside. Turn off the rotisserie burner once the food has browned to the desired colour. Finish cooking on indirect heat. ♦

TO EXTINGUISH

Push in and turn the rotisserie burner control knob clockwise to OFF position. Turn gas supply off at the source. ♦

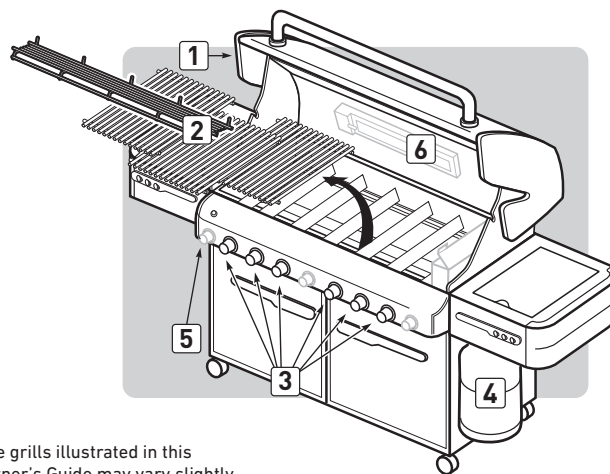

The grills illustrated in this Owner's Guide may vary slightly from the model purchased.

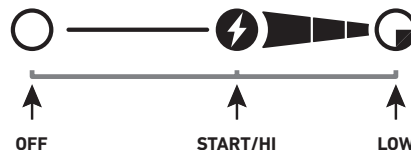
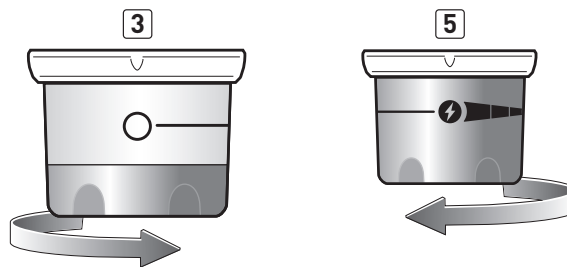

ROTISSERIE BURNER IGNITION & USAGE

ROTISSERIE BURNER MANUAL IGNITION

⚠ ATTENTION: READ BEFORE LIGHTING ROTISSERIE BURNER

After a period of non-use, before lighting the Rotisserie Burner, a few seconds must pass for the gas supply line to fill.

When holding a match to the rotisserie burner you will see a flash of flames moving from left to right across the Rotisserie Burner surface, the Rotisserie Burner is not lit until the entire ceramic surface is aflame.

At this point, start a count of twenty seconds before releasing the Rotisserie Burner control knob.

The Rotisserie Burner surface will glow red once the burner is fully ignited.

⚠ DANGER

Failure to open the lid while igniting the grill, or not waiting five minutes to allow the gas to clear if the grill does not light, may result in an explosive flare-up, which can cause serious bodily injury or death.

- ⚠ CAUTION: The Rotisserie Burner flame may be difficult to see on a sunny day.
- ⚠ WARNING: Always check hose before using grill for nicks, cracking, abrasions or cuts. If the hose is found to be damaged in any way, do not use the grill. Replace using only a WEBER authorised replacement hose. Contact the Customer Service Representative in your area using the contact information on our web site.
Log onto www.weber.com.

- A) Open the lid (1).
- B) Remove the warming rack and the cooking grates from the cookbox (2).
- C) Make sure all burner control knobs are turned off (3). (Push control knob down and turn clockwise to ensure that it is in the OFF position.)
- ⚠ WARNING: The burner control knobs must be in the OFF position before turning on the liquid propane cylinder tank valve.
- D) Turn on the cylinder valve using one of the appropriate options based on your cylinder and regulator type (4).
- E) Put a match in the match holder and strike the match.
- F) Hold match holder and lit match by right side of rotisserie burner (5).

⚠ WARNING: Do not lean over the open grill.

- G) Push rotisserie burner control knob down and turn to START/Hi. Continue to hold the control knob down for twenty seconds after the burner has ignited (6).
- H) Check that the burner is lit by looking for the rotisserie burner to glow red (7).
- ⚠ WARNING: If the rotisserie burner does not light, turn the burner control knob to OFF and wait five minutes to let the gas clear before you try again.

NOTE: When using the rotisserie with the lid closed, only light two of the main burners under the food (refer to "COOKING METHODS-INDIRECT COOKING"). Check your food periodically to prevent overcooking on the outside. Turn off the rotisserie burner once the food has browned to the desired colour. Finish cooking on indirect heat. ♦

TO EXTINGUISH

Push in and turn the rotisserie burner control knob clockwise to OFF position. Turn gas supply off at the source. ♦

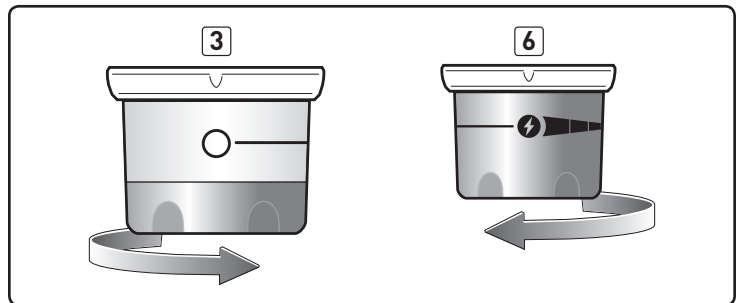
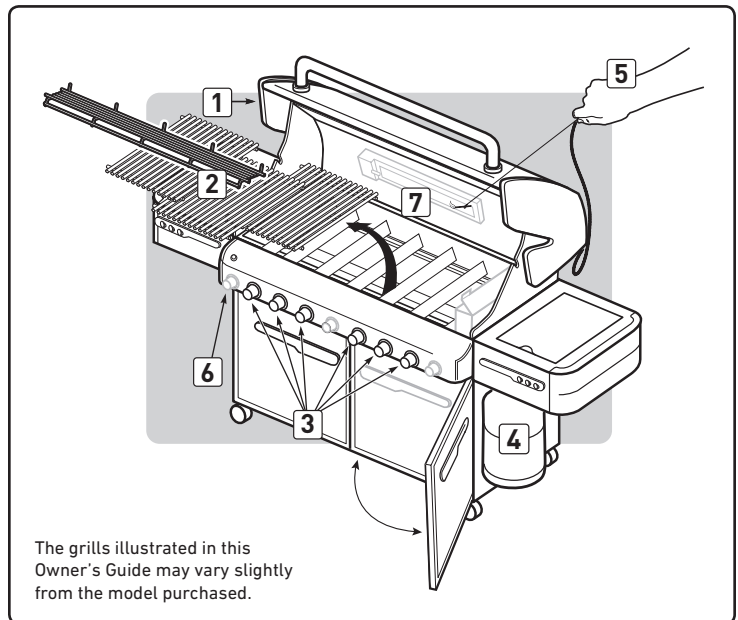

ROTISSERIE BURNER IGNITION & USAGE

IMPORTANT SAFEGUARDS

NOTE: Before using your rotisserie, measure your food at the widest point. If it exceeds 9 1/2" (241.8mm), it is too large to fit the rotisserie. If it is too large, food can be prepared using a roast holder and the Indirect Cooking Method.

⚠ WARNINGS

- ⚠ Read all instructions before using your rotisserie.
- ⚠ This rotisserie is for outdoor use only.
- ⚠ Do not expose to rain.
- ⚠ Do not use rotisserie for any purpose other than its intended use.
- ⚠ This rotisserie is not for use by children.
- ⚠ Use heat-resistant barbecue mitts or gloves (conforming to EN 407, Contact Heat rating level 2 or greater) when operating barbecue.
- ⚠ Make sure motor is off before placing it on the motor bracket.
- ⚠ Remove motor and store in a dry place when not in use.
- ⚠ Unplug the motor from outlet when not in use, or before cleaning.
- ⚠ Do not operate the rotisserie motor if it should malfunction.
- ⚠ Do not operate the rotisserie motor with a damaged cord or plug.
- ⚠ Do not let power cord hang over any sharp edge or hot surface.
- ⚠ To protect against electrical hazards do not immerse cord, plug, or motor in water or other liquids.
- ⚠ A short cord is supplied to reduce the risk of tripping over the cord. Extension cords may be used, but caution must be taken to prevent tripping over the cord.
- ⚠ If using an extension cord, it must be designed for outdoor use and rated at 10A/230V.
- ⚠ When using an extension cord, make sure it is not in contact with a hot or sharp surface.
- ⚠ Use the shortest length extension cord possible. Do not connect two or more extension cords together.
- ⚠ To reduce the risk of electric shock, keep extension cord connection dry and off the ground.
- ⚠ The appliance is to be connected to a socket-outlet having an earthing contact.
- ⚠ If any electrical plug adapter is used, it must ground the appliance.
- ⚠ Always ensure that the electrical socket being used has the correct voltage (230 V).
- ⚠ Failure to follow these warning statements may cause electric shock, which may result in serious bodily injury or property damage. ♦

OPERATING THE ROTISSERIE

⚠ WARNING: Set up the rotisserie with food before lighting rotisserie burner.

- A) To set up rotisserie motor, push the button on the retractable rotisserie panel (1). Pull rotisserie panel upwards. Push locking tab (2) until it snaps into place.
- ⚠ CAUTION: Do not route rotisserie motor power lead through the retractable rotisserie opening in the side table.
- ⚠ CAUTION: Inspect power lead before each use. If lead is damaged, do not use. Contact the Customer Service Representative in your area using the contact information on our web site. Log onto www.weber.com.
- C) Make sure the rotisserie shaft handle is securely fastened. Slide one of the spit forks towards the right side of the rotisserie shaft, making sure that the spikes face to the left and the fork screw faces down (3).
- D) Push the rotisserie shaft through the center of the food. Insert the tines of both spit forks into the food. The food should be centered on the shaft. Tighten the spit fork screw (4).
- E) Slide another spit fork onto the rotisserie shaft, making sure that the spikes face to the right and the fork screw faces up. Insert the tines of both spit forks into the food. Tighten the spit fork screw (5).

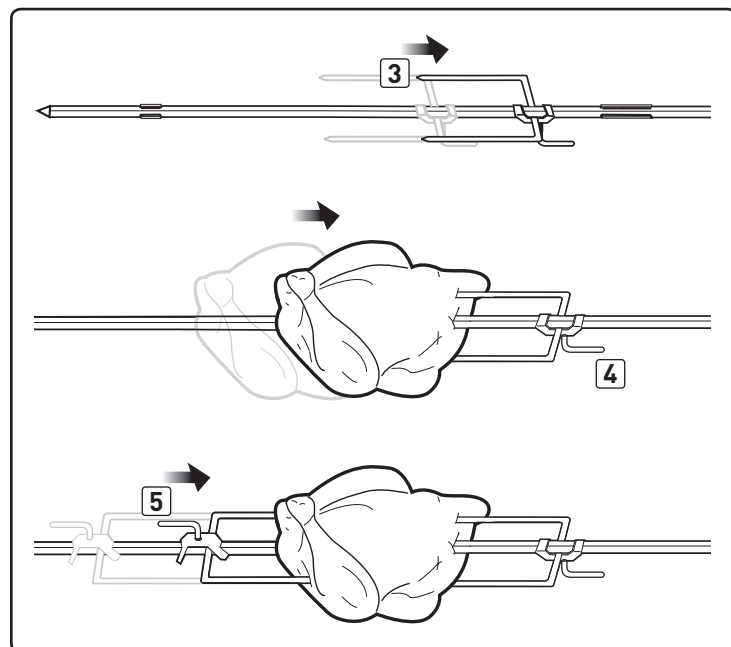
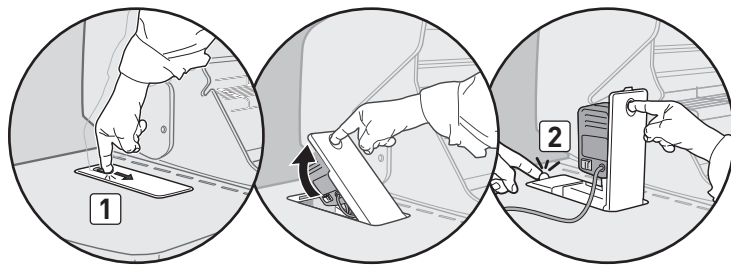

ROTISSERIE BURNER IGNITION & USAGE

- F) Insert the pointed end of the rotisserie shaft into the motor. Lower the rotisserie spit into the grooves on the cookbox (6).
- G) The rotisserie shaft should rotate so that the heavy side of the meat or poultry rotates down to the bottom. Large cuts may require the removal of the cooking grates and warming rack to allow full rotation of the shaft. Remount the food if necessary for better balance.
- H) Remove the rotisserie shaft handle; the handle has left-hand threads, by turning the handle clockwise until free from threads (7).

⚠ CAUTION: The handle can become hot if left attached to the rotisserie shaft while cooking. Do not cook with the handle installed.

- I) Turn the motor on. ♦

ROTISSERIE COOKING

- Meats (except poultry and ground meat) should be brought to room temperature before cooking. (20 to 30 minutes should be adequate for most foods. If frozen, defrost completely before cooking.)
- Tie meat or poultry with a string, if necessary, to make the shape as uniform as possible before putting it on the spit.
- Remove cooking grates and warming rack to allow food to turn freely.
- Follow lighting instructions for rotisserie burner.
- Set rotisserie burner on medium-high based on outside air temperatures.
- Place food within area of burner.
- If you wish to save drippings for gravy, place a drip pan directly under the food on top of the FLAVORIZER BARS.
- Food preparation steps are the same for rotisserie cooking as for regular cooking.
- All cooking is done with the lid closed.
- If foods are too heavy or are irregular shapes, they may not rotate well and should be cooked by the Indirect Method without using the rotisserie.
- Smoker can be used in conjunction with rotisserie for more smoke flavour.

Note: When using the rotisserie burner, grill thermometer will not reflect the temperature inside the cooking box.

⚠ CAUTION: Before removing the rotisserie with the cooked food from the grill, be sure to replace the rotisserie shaft handle by turning the handle counterclockwise until securely fastened on the shaft. ♦

ROTISSERIE MOTOR STORAGE

- A) Before retracting rotisserie back into the side table, unplug the power lead and carefully place plug/power lead into the storage area of the retractable rotisserie assembly (1).

⚠ CAUTION: Failure to properly store the rotisserie power lead may result in damage to the power lead when opening and closing the retractable rotisserie panel.

- B) Using your index finger, disengage retractable rotisserie panel (2). Push panel down until it snaps securely in place (3). ♦

ROTISSERIE SPIT STORAGE

- A) Remove forks from rotisserie spit. Replace rotisserie shaft handle. Carefully insert spit into cabinet by sliding through hole in right side panel (1).

⚠ CAUTION: Do not allow rotisserie spit to come into contact with any gas lines.

- B) Store rotisserie forks by placing them on the hooks located on the catch pan holder within the grill cabinet (2). ♦

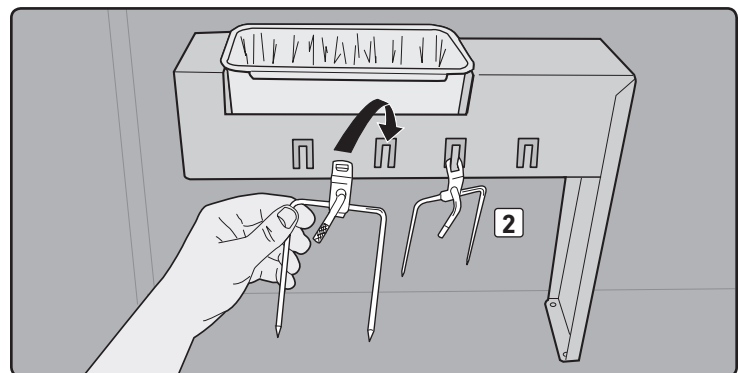
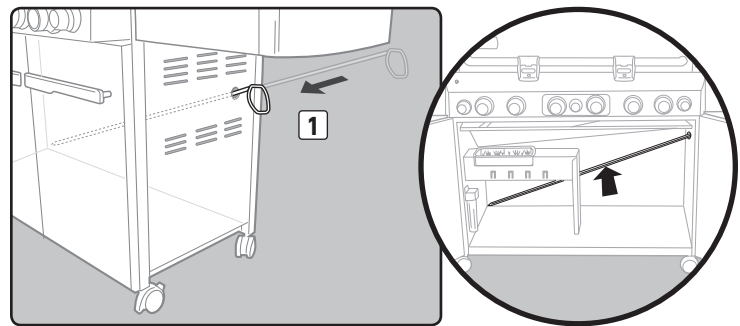
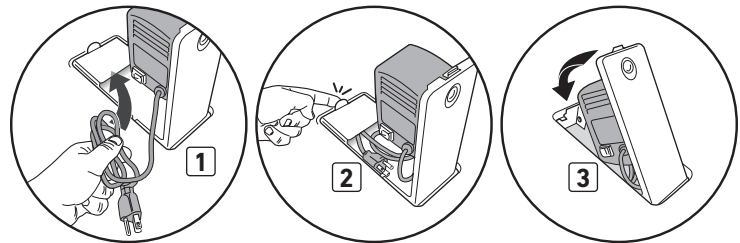
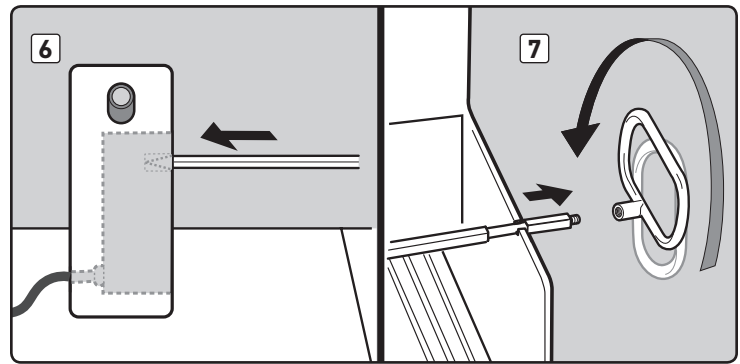

TROUBLESHOOTING

PROBLEM	CHECK	SOLUTION
Burners burn with a yellow or orange flame, in conjunction with the smell of gas. (This is normal for the burner lighting tube).	Inspect Spider/Insect screens for possible obstructions (blockage of holes).	Clean Spider/Insect screens. Refer to "ANNUAL MAINTENANCE".
Symptoms: Burners do not light, or Burners have a small flickering flame in the HI position, or Grill temperature only reaches 250° to 300° in the HI position. <i>Some countries have regulators with an excess gas flow safety device.</i>	The excess gas flow safety device, which is part of the grill-to-cylinder connection, may have been activated.	To reset the excess gas flow safety device, turn all burner control knobs and the cylinder valve off. Disconnect the regulator from the cylinder. Turn burner control knobs to HI. Wait at least 1 minute. Turn burner control knobs to OFF. Reconnect the regulator to the cylinder. Turn cylinder valve on slowly. Refer to "MAIN BURNER IGNITION".
Burner does not light, or flame is low in HI position.	Is LP fuel low or empty?	Refill LP cylinder.
	Is fuel hose bent or kinked?	Straighten fuel hose.
	Does burner light with a match?	If you can light burner with a match, then check the ignition system.
	Did you use the snap igniter several times until the main burner lit? Refer to "MAIN BURNER IGNITION".	Make sure you hold the control knob in for two seconds after snapping the igniter and seeing the orange flame from the burner lighting tube.
	Does the igniter work? Do you see a spark when you repeatedly use the snap igniter?	Try manually lighting the burner. Refer to "MAIN BURNER MANUAL IGNITION". Call Customer Service.
Experiencing flare-ups: ⚠ CAUTION: Do not line the slide-out grease tray with aluminum foil.	Are you preheating grill in the prescribed manner?	All burners on HI for 10 to 15 minutes for preheating.
	Are the cooking grates and FLAVORIZER BARS heavily coated with burned-on grease?	Clean thoroughly. Refer to "CLEANING".
	Is the slide-out grease tray dirty and not allowing grease to flow into catch pan?	Clean slide-out grease tray.
Burner flame pattern is erratic. Flame is low when burner is on HI. Flames do not run the whole length of the burner tube.	Are burners clean?	Clean burners. Refer to "MAINTENANCE".
Inside of lid appears to be "peeling." (Resembles paint peeling.)	The lid is porcelain enamel or stainless steel, not paint. It cannot "peel". What you are seeing is baked on grease that has turned to carbon and is flaking off. THIS IS NOT A DEFECT.	Clean thoroughly. Refer to "CLEANING".
Cabinet doors are not aligned.	Check the adjustment pin on the bottom of each door.	Loosen adjustment nut(s). Slide door(s) until aligned. Tighten nut.
Grill seems to lose heat when cooking in cold weather temperatures of 10°C (50°F) or colder.	Is there frost/ice on the outside of the LP cylinder?	The liquid propane in the cylinder turns to vapour too slowly to supply the burners with gas. This is due to the air temperature cooling the LP cylinder, which slows the vaporisation process. Turn off burner control knobs and the LP cylinder. Replace with a spare LP cylinder and resume cooking.
If problems cannot be corrected by using these methods, please contact the Customer Service Representative in your area using the contact information on our web site. Log onto www.weber.com.		

SIDE BURNER TROUBLESHOOTING

PROBLEM	CHECK	SOLUTION
Side Burner does not light. <i>Some countries have regulators with an excess gas flow safety device.</i>	Is gas supply off? The excess gas flow safety device, which is part of the grill-to-cylinder connection, may have been activated.	Turn gas supply on. To reset the excess gas flow safety device close the LP tank valve and turn all burner control knobs to the OFF position. Open the grill and side burner lids. Slowly turn the LP tank valve until it is completely open. Wait several seconds then ignite your side burner. Refer to "SIDE BURNER IGNITION".
Flame is low in HI position.	Is the fuel hose bent or kinked?	Straighten hose.
Push button ignition does not work.	Does burner light with a match?	If match lights burner, check igniter. Refer to "SIDE BURNER MAINTENANCE".
	Is there a fresh battery installed?	Verify that the battery is in good condition and installed correctly. Refer to "ELECTRONIC IGNITION SYSTEM OPERATIONS."
	Are the wires connected properly to the igniter module?	Be sure that wires are correctly inserted into terminals on ignition box. Refer to "SIDE BURNER MAINTENANCE."
	Is there plastic wrapping around the new battery?	Remove plastic wrapping.
If problems cannot be corrected by using these methods, please contact the Customer Service Representative in your area using the contact information on our web site. Log onto www.weber.com.		

SEAR STATION TROUBLESHOOTING

PROBLEM	CHECK	SOLUTION
Burners burn with a yellow or orange flame, in conjunction with the smell of gas (This is normal for the burner lighting tube). SEAR STATION burner does not light.	Inspect Spider/Insect screens for possible obstructions. (Blockage of holes.)	Clean Spider/Insect screens. Refer to "ANNUAL MAINTENANCE".
	Did you ignite the two adjacent main burners? Refer to "SEAR STATION IGNITION & USAGE" instructions for safe lighting procedure.	Verify adjacent main burner ignition by visually inspecting for a flame. ⚠ WARNING: If ignition does not occur within five seconds, turn burner control OFF, wait five minutes to let the gas clear before you try again.
	Does burner light with a match?	If you can light Burner with a match, then check the Crossover Channel on the sear burner. Refer to "MAINTENANCE" for burner removal and cleaning procedure.
	Does the igniter work? (Do you see a spark when you repeatedly use the snap igniter?)	Try manually lighting the burner. Refer to "SEAR STATION IGNITION & USAGE". Call Customer Service.
General Symptoms: Burner does not light -or- Burner has a small flickering flame. <i>Some countries have regulators with an excess gas flow safety device.</i>	The excess flow safety device, which is part of the grill-to-cylinder connection, may have activated.	To reset the excess flow safety device, turn all burner control knobs and the cylinder valve to OFF. Disconnect the regulator from the cylinder. Turn burner control knobs to START/HI. Wait at least one minute. Turn burner control knobs to OFF. Reconnect the regulator to the cylinder. Turn cylinder valve on slowly. Refer to "MAIN BURNER IGNITION").
If problems cannot be corrected by using these methods, please contact the Customer Service Representative in your area using the contact information on our web site. Log onto www.weber.com.		

ROTISSERIE TROUBLESHOOTING

PROBLEM	CHECK	SOLUTION
Rotisserie burner does not light.	Did you push the burner control knob in and hold it in for 20 seconds after the burner ignited?	Try to relight burner by holding burner control knob in and continue holding in for 20 seconds after burner has ignited.
	Did you wait to see the entire ceramic surface light up before counting 20 seconds?	When relighting burner by holding burner control knob in, wait to see the entire ceramic surface become alight before counting 20 seconds.
	Did you repeatedly use the snap ignition until the burner ignited?	After waiting five minutes for gas to clear, try repeatedly to use the snap igniter until the burner ignites. Refer to "ROTISSERIE BURNER IGNITION & USAGE".
	Does the igniter work? Do you see a spark when you repeatedly use the snap igniter?	Try manually lighting the burner. Refer to "ROTISSERIE BURNER MANUAL IGNITION". Call Customer Service.
General Symptoms: Burner does not light, or Burner has a small flickering flame. <i>Some countries have regulators with an excess gas flow safety device.</i>	The excess flow safety device, which is part of the grill-to-cylinder connection, may have activated.	To reset the excess flow safety device, turn all burner control knobs and the cylinder valve to OFF. Disconnect the regulator from the cylinder. Turn burner control knobs to START/HI. Wait at least 1 minute. Turn burner control knobs to OFF. Reconnect the regulator to the cylinder. Turn cylinder valve on slowly. Refer to "MAIN BURNER IGNITION".
If problems cannot be corrected by using these methods, please contact the Customer Service Representative in your area using the contact information on our web site. Log onto www.weber.com.		

GRILL LIGHT TROUBLESHOOTING

PROBLEMS	SOLUTIONS
Grill light does not turn on.	The grill light will activate only when lid is open. Lift the lid to the open position and press the AWAKE button.
	Install new batteries. When installing new batteries (alkaline only), confirm that each battery's plastic wrapping has been removed. Verify that the batteries are in good condition and have been installed correctly. Refer to "MAINTAINING THE GRILL LIGHT."
Grill light turned off and will not turn back on.	The light is programmed to turn off automatically after 30 minutes of inactivity. To reactivate the light, make sure lid is open and press the AWAKE button. Refer to "MAINTAINING THE GRILL LIGHT."
Grill light does not turn off.	The grill light is equipped with a tilt sensor. The tilt sensor turns the light ON when grill lid is opened and OFF when the grill lid is closed. NOTE: The AWAKE button will not turn the grill light off. To turn the light off, put the lid in the closed position.
If problems cannot be corrected by using these methods, please contact the Customer Service Representative in your area using the contact information on our web site. Log onto www.weber.com.	

MAINTENANCE

CLEANING

- ⚠ **WARNING:** Turn your gas grill off and wait for it to cool before cleaning.
- ⚠ **CAUTION:** Do not clean your **FLAVORIZER BARS** or cooking grates in a self-cleaning oven.

Outside surfaces — Use a warm soapy water solution to clean; then rinse with water.

- ⚠ **CAUTION:** Do not use oven cleaner, abrasive cleansers (kitchen cleansers), cleaners that contain citrus products, or abrasive cleaning pads on grill or cart surfaces.

Slide-out grease tray — Remove excess grease; then wash with warm soapy water; then rinse with water.

- ⚠ **CAUTION:** Do not line the slide-out grease tray with aluminum foil.

FLAVORIZER BARS and cooking grates — Clean with a suitable stainless steel bristle brush. As needed, remove from grill and wash with warm soapy water; then rinse with water.

For availability of replacement cooking grates and **FLAVORIZER BARS**, contact the Customer Service Representative in your area using the contact information on our website. Log onto www.weber.com.

Catch pan — Disposable foil trays are available, or you can line the catch pan with aluminum foil. To clean the catch pan, wash with warm soapy water; then rinse.

Thermometer — Wipe with warm soapy water; clean with plastic scrub ball.

Cookbox - Brush any debris off burner tubes. **DO NOT ENLARGE BURNER PORTS (OPENINGS)**. Wash inside of cookbox with warm soapy water and rinse with water.

Inside lid — While lid is warm, wipe inside with paper towel to prevent grease build-up. Flaking, built-up grease resembles paint flakes.

Stainless steel surfaces — Wash with a soft cloth and a soap-and-water solution. Be careful to scrub with the grain direction of the stainless steel.

Do not use cleaners that contain acid, mineral spirits or xylene. Rinse well after cleaning. ♦

PRESERVE YOUR STAINLESS STEEL

Your grill or its cabinet, lid, control panel and shelves may be made from stainless steel. To keep the stainless steel looking its best is a simple matter. Clean it with soap and water, rinse with clear water, and wipe dry. For stubborn particles, a non-metallic brush can be used.

- ⚠ **IMPORTANT:** Do not use a wire brush or abrasive cleaners on the stainless steel surfaces of your grill as this will cause scratches.
- ⚠ **IMPORTANT:** When cleaning surfaces be sure to rub/wipe in the direction of the grain to preserve the look of your stainless steel. ♦

SPIDER/INSECT SCREENS

Your gas grill, as well as any outdoor gas appliance, is a target for spiders and other insects. They can nest in the venturi section (1) of the burner tubes. This blocks the normal gas flow, and can cause the gas to flow back out of the combustion air opening. This could result in a fire in and around the combustion air openings, under the control panel, causing serious damage to your grill.

The burner tube combustion air opening is fitted with a stainless steel screen (2) to prevent spiders and other insects from accessing the burner tubes through the combustion air openings.

We recommend that you inspect the spider/insect screens at least once a year. (Refer to "ANNUAL MAINTENANCE.") Also inspect and clean the spider/insect screens if any of the following symptoms should ever occur:

- A) Gas is smelled in conjunction with burner flames that appear yellow and lazy.
- B) Grill does not reach temperature.
- C) Grill heats unevenly.
- D) One or more of the burners do not ignite.

⚠ DANGER

Failure to correct the above mentioned symptoms may result in a fire, which can cause serious bodily injury or death, and cause damage to property.

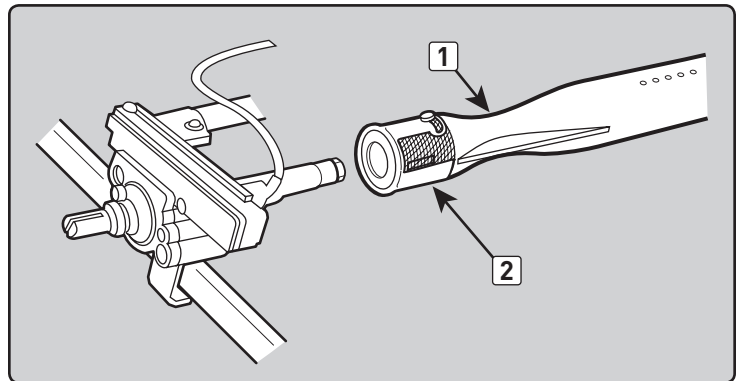

BURNER TUBE CLEANING

Turn off the gas supply.

Remove the manifold (refer to "REPLACING MAIN BURNERS").

Look inside each burner with a torch.

Clean the inside of the burners with a wire (a straightened-out coat hanger will work). Check and clean the air shutter opening at the ends of the burners. Check and clean the valve orifices at the base of the valves. Use a steel bristle brush to clean outside of burners. This is to make sure all the burner ports are fully open.

- ⚠ **CAUTION:** Do not enlarge the burner ports when cleaning. ♦

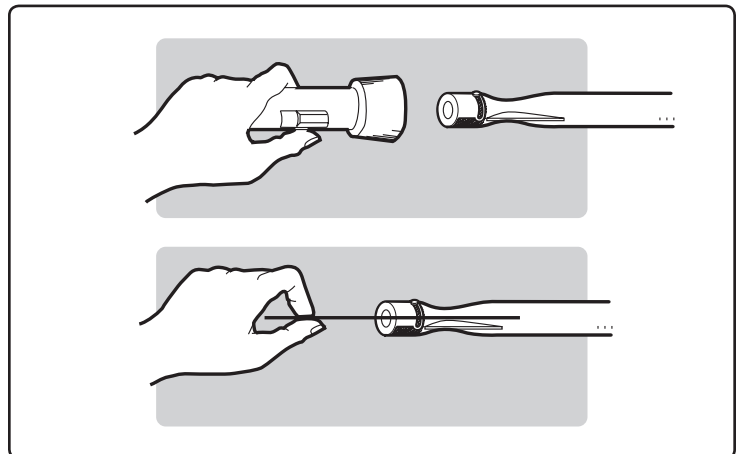

REPLACING MAIN BURNERS

Note: Your SUMMIT gas grill must be off and cool.

- A) Turn gas off at source.
- B) Disconnect gas supply.
- C) Remove cooking grates.
- D) Remove FLAVORIZER BARS.
- E) Remove smoker box (if included with your model).

Remove Control Panel

Tools needed: Screwdriver, pliers, and towels.

- A) Remove burner control knobs (1).
- B) Open both doors. With a screwdriver, remove screws from the underside of control panel (2).
- C) Lift and remove battery housing located inside grill cabinet (3).
- D) Using needle-nose pliers, disconnect wire terminals from the top of battery housing (4). Do not pull on the wires; remove them by pulling on the wire terminals.
- E) Place towels on the tops of both door assemblies. **This will protect control panel and door assemblies from getting scratched on next step.**
- F) Tilt bottom of control panel forward. Lift slightly (5) and then rotate it face down to rest on tops of door assemblies. **(Be careful not to break or disconnect wires for the control panel LEDs.)**
- G) Carefully pull battery wires out from the inside of the grill cabinet (6).
- H) Fully open right door. Place control panel on floor, leaning against towel covering right door assembly (7).

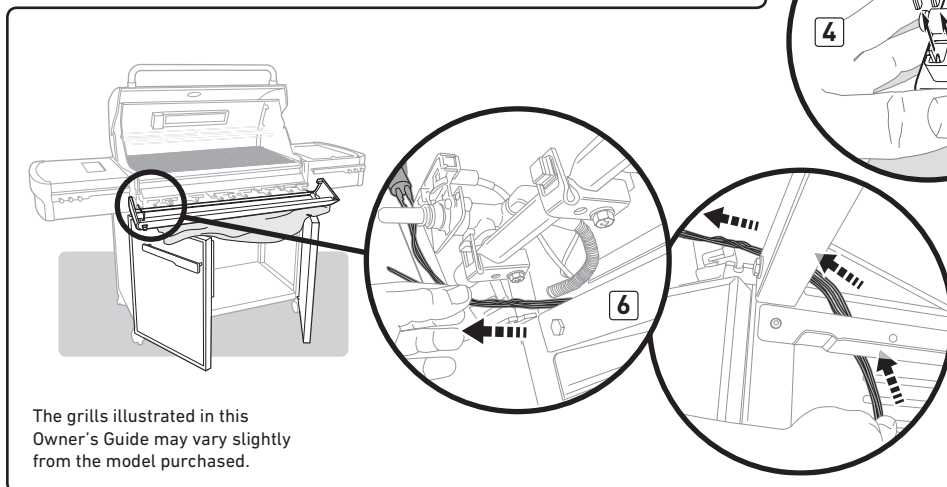
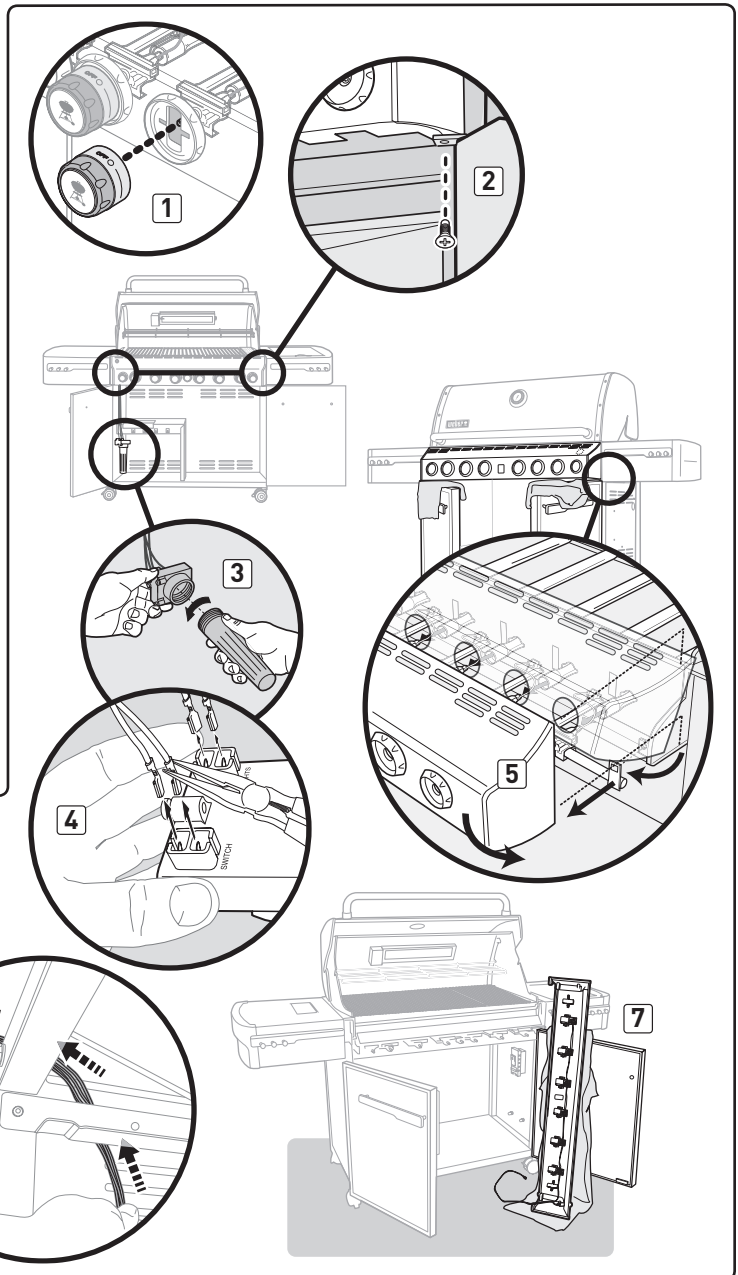

The grills illustrated in this Owner's Guide may vary slightly from the model purchased.

Remove Burner Tubes

Tools needed: 5/16" and 3/8" spanners.

- A) Using a 5/16" spanner, remove screws securing Crossover channel. Remove Crossover channel from inside rear of cookbox (8).
- B) Using a 3/8" spanner, remove the screws that secure manifold assembly to the cookbox. Pull manifold assembly away from burner tubes and let it hang loose from grill cabinet (9). Do not disconnect the blue wire from the left side of the manifold assembly.
- C) Pull the selected burner tube(s) through the front of cookbox and replace with new burner tube(s) (10).

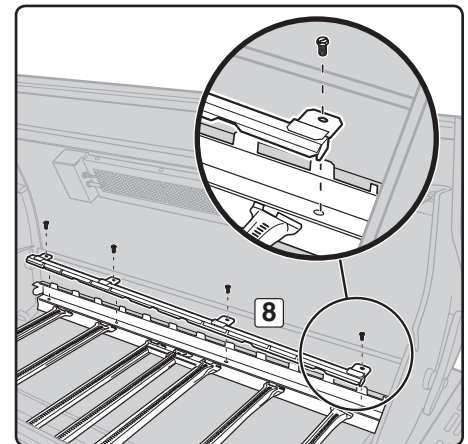
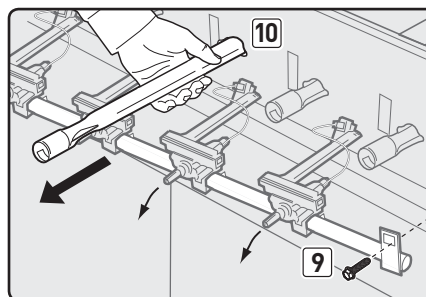

MAINTENANCE

Remove SEAR STATION Burner

To remove the SEAR STATION burner, pull the burner tube toward you. This removes it from the burner tube notch (11). Then rotate the tube clockwise (12), so that the screw at the end of the tube (13) fits through the notch in the heat shield opening (14). When the burner tube is free, remove it from the cookbox (15).

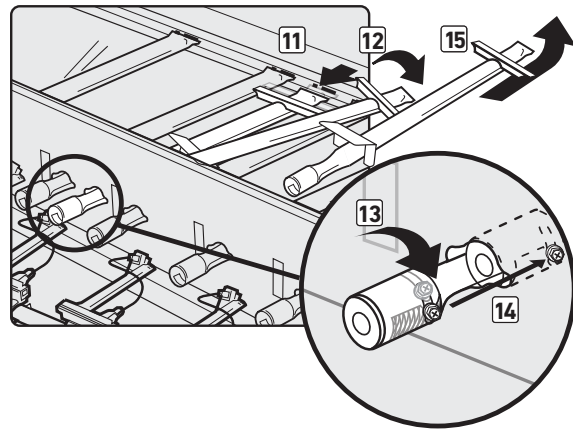

Reinstall Manifold

A) To reinstall the manifold assembly, reverse steps for "Remove Burner Tubes" as previously described.

⚠ **CAUTION:** The burner openings (16) must be positioned properly over the valve orifices (17). Make sure the opposite end of the burner tubes (18) properly align into the slots on the backside of the cookbox. Check proper assembly before fastening manifold in place.

⚠ **WARNING:** You should check for gas leaks every time you disconnect and reconnect a gas fitting. Refer to CHECKING FOR GAS LEAKS.

B) Replace cookbox components (not pictured).

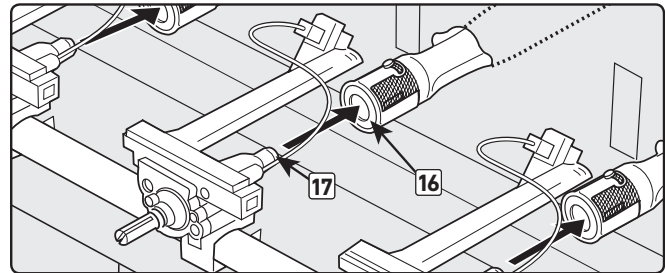

Reinstall Control Panel

A) To reinstall the control panel assembly, reverse steps for "Remove Control Panel" as previously described.

B) Verify proper wire connections. Refer to "LIGHT FEATURES".

⚠ **WARNING:** Make sure that all parts are assembled and hardware is fully tightened before operating the grill. Your actions, if you fail to follow this product warning, may cause a fire, an explosion, or structural failure resulting in serious personal injury or death as well as damage to property. ♦

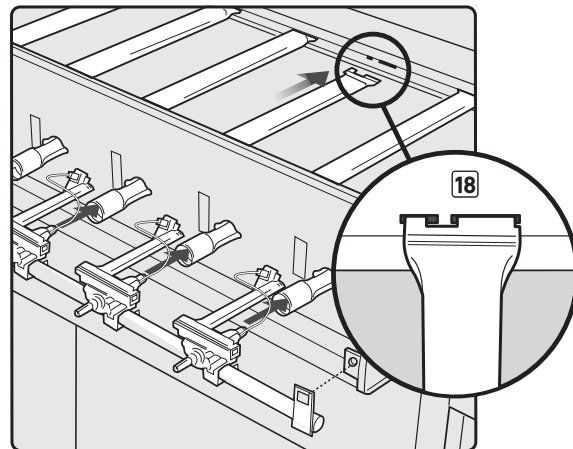

SIDE BURNER MAINTENANCE

⚠ **WARNING:** All gas controls and supply valves should be in the OFF position.

Make sure black wire is connected between the igniter and electrode.

Make sure white wire is connected between the igniter and earthing clip.

Spark should be a white/blue colour, not yellow.

- A) Igniter wire (1)
- B) Earth wire (2)
- C) Burner (3) ♦

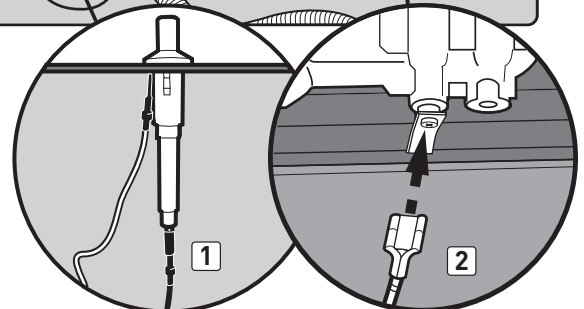
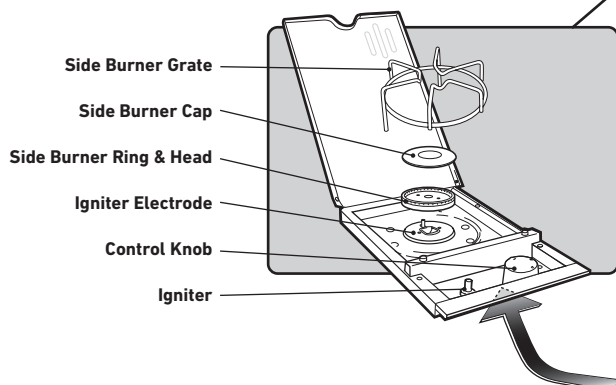
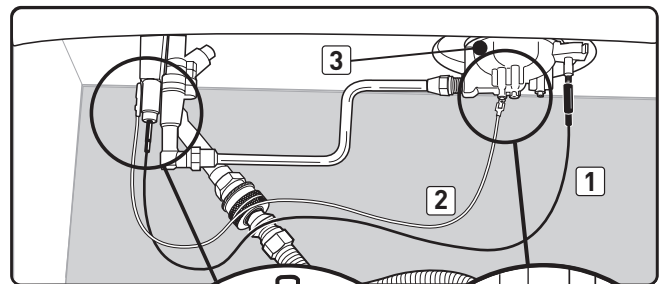

ANNUAL MAINTENANCE

Inspection and Cleaning of the Spider/Insect Screens

To inspect the spider/insect screens, remove the control panel. If there is dust or dirt on the screens, remove the burners to clean the screens.

Brush the spider/insect screens lightly with a soft bristle brush (i.e., an old toothbrush).

⚠ CAUTION: Do not clean the spider/insect screens with hard or sharp tools. Do not dislodge the spider/insect screens or enlarge the screen openings.

Lightly tap the burner to get debris and dirt out of the burner tube. Once the spider/insect screens and burners are clean, reinstall the burners.

If the spider/insect screen becomes damaged or cannot be cleaned, please contact the Customer Service Representative in your area using the contact information on our web site. Log onto www.weber.com.

Burner Flame Pattern

The gas grill burners have been factory set for the correct air and gas mixture. The correct flame pattern is shown.

- A) Burner tube (1)
- B) Tips occasionally flicker yellow (2)
- C) Light blue (3)
- D) Dark blue (4)

If the flames do not appear to be uniform throughout the burner tube, follow the burner cleaning procedures. ♦

MAINTAINING THE GRILL LIGHT

- When installing three new AAA batteries (alkaline only), confirm that each battery's plastic wrapping has been removed. Do not confuse this plastic with the battery label.
- Do not mix old and new batteries or different types of batteries (standard, alkaline or rechargeable).
- Verify that the batteries are in good condition and have been installed correctly.
- If you do not plan to use the light for a month or more, remove the batteries.
- Wipe the light clean with a damp cloth only. Do not use alcohol-based or abrasive cleaners.
- The light is weather resistant to rain and snow, but not waterproof. Do not submerge in water / liquids.
- Light is heat resistant. Grease fires or running the grill on high for an excessive amount of time can damage internal components.

Press the AWAKE button to activate the grill light. The light has a 'tilt sensor' that will turn on the light if the grill lid is opened and turn off the light when the grill lid is closed. If the lid is left open or closed for more than 30 minutes, the grill light will deactivate. To turn the light back on, press the AWAKE button (5).

NOTE: The light does not turn OFF by pressing the AWAKE button. ♦

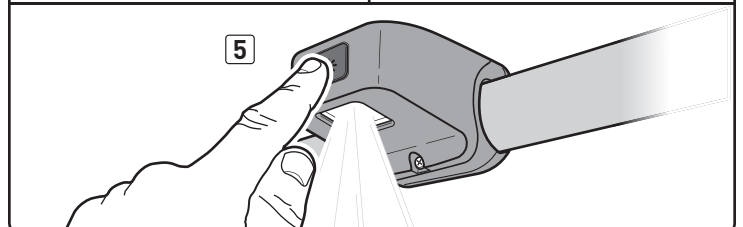
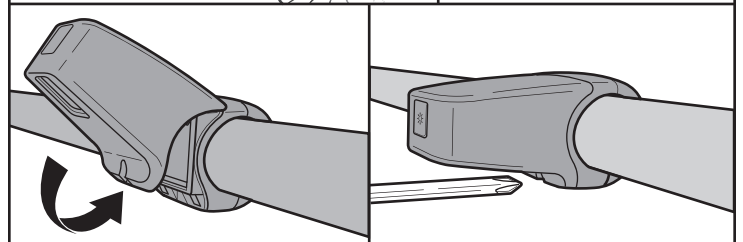
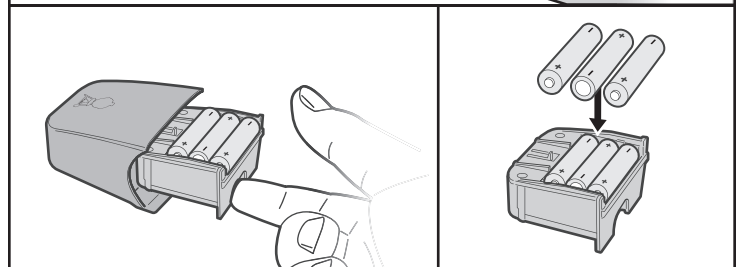
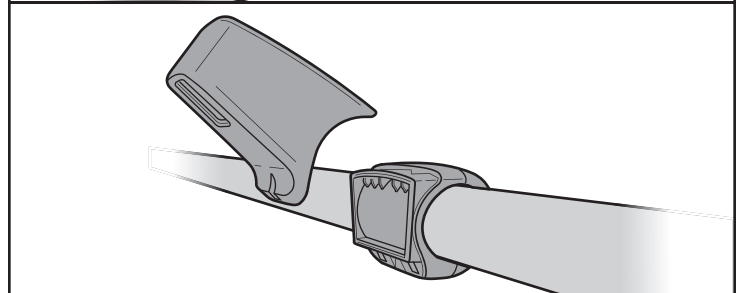
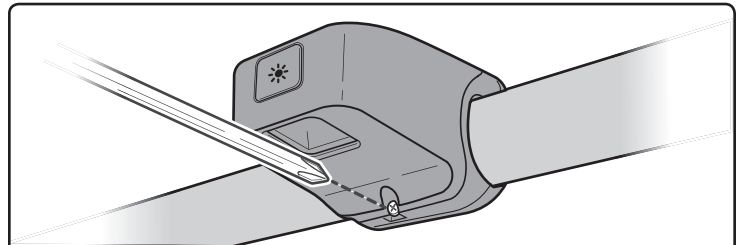
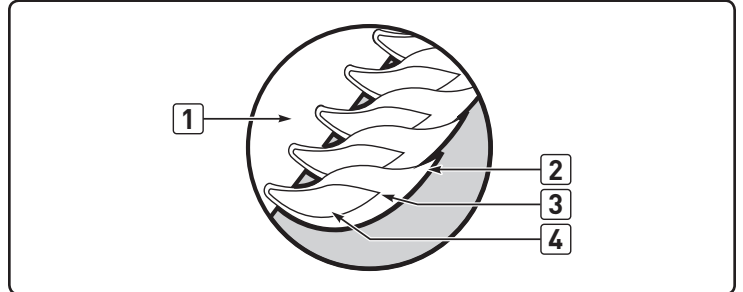
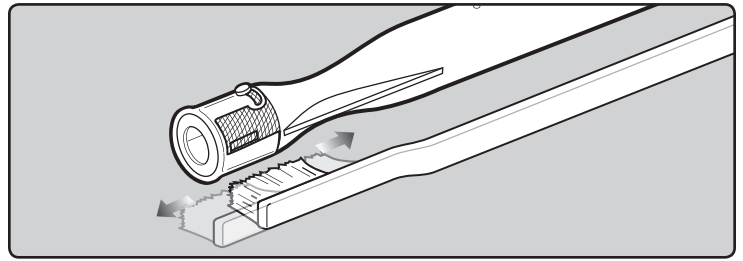

⚠ ATTENTION: This product has been safety-tested and is only certified for use in a specific country. Refer to country designation located on outside of box.

These parts may be gas-carrying or gas-burning components. Please contact Weber-Stephen Products LLC Customer Service Department for genuine Weber-Stephen Products LLC replacement part(s) information.

⚠ WARNING: Do not attempt to make any repair to gas-carrying or gas-burning components without contacting Weber-Stephen Products LLC Customer Service Department. Your actions, if you fail to follow this product warning, may cause a fire or an explosion resulting in serious personal injury or death and damage to property.

AUSTRALIA

Weber-Stephen Products LLC
R. McDonald Co. PTY. LTD.
+61.8.8221.6111

AUSTRIA

Weber-Stephen Österreich GmbH
+43 7242 890 135 0
info-at@weberstephen.com

BELGIUM

Weber-Stephen Products Belgium Sprl
+32 015 28 30 90
infobelux@weberstephen.com

CHILE

Weber-Stephen Chile SpA.
+01 56 2-3224-3936

CZECH REPUBLIC

Weber-Stephen CZ & SK spol. s r.o.
+42 267 312 973
info-cz@weberstephen.com

DENMARK

Weber-Stephen Nordic ApS
+45 99 36 30 10
info@weberstephen.dk

FRANCE

Weber-Stephen France
+33 810 19 32 37
service.consommateurs@weberstephen.com

GERMANY

Weber-Stephen Deutschland GmbH
+49 6132 8999 0
info-de@weberstephen.com

HUNGARY

Weber-Stephen Magyarország Kft.
+36 70 / 70-89-813
info-hu@weberstephen.com

ICELAND

Jarn & Gler Wholesale EHF
+354 58 58 900

INDIA

Weber-Stephen Barbecue Products India Pvt. Ltd.
080 42406666
customercare@weberindia.com

ISRAEL

D&S Imports
+972 392 41119
info@weber.co.il

ITALY

Weber-Stephen Products Italia Srl
+39 0444 360 590
info-italia@weberstephen.com

MEXICO

Weber-Stephen Products S.A. de C.V.
+01800-00-WEBER [93237] Ext. 105

NETHERLANDS

Weber-Stephen Netherlands B.V.
+31 513 4333 22
info@weberbarbecues.nl

NEW ZEALAND

WEBER New Zealand ULC
+64 9 570 6630

POLAND

Weber-Stephen Polska Sp. z o.o.
+48 22 392 04 69
info-pl@weberstephen.com

RUSSIA

Weber-Stephen Vostok LTD.
+7 495 956 63 21
info.ru@weberstephen.com

SOUTH AFRICA

Weber-Stephen Products (South Africa) (Pty) Ltd.
+27 11 454 2369
info@weber.co.za

SPAIN

Weber-Stephen Iberica Srl
+34 93 584 40 55
infoiberica@weberstephen.com

SWITZERLAND

Weber-Stephen Schweiz GmbH
+41 52 24402 50
info-ch@weberstephen.com

TURKEY

Dost Bahce Dis Ticaret Müessilik Anonim Sirketi
+49 6132 8999 0
info-de@weberstephen.com

UNITED ARAB EMIRATES

Weber-Stephen Nordic Middle East
+971 4 360 9256
info@weberstephen.ae

UNITED KINGDOM

Weber-Stephen Products (UK) Ltd.
+44 (0)203 630 1500
customerserviceuk@weberstephen.com

USA

Weber-Stephen Products LLC
847 934 5700
support@weberstephen.com

For Republic of Ireland, please contact:
Weber-Stephen Products (U.K.) Limited.

For other eastern European countries, such as ROMANIA,
SLOVENIA, CROATIA, or GREECE, please contact:
Weber-Stephen Deutschland GmbH.

For Baltic states, please contact:
Weber-Stephen Nordic ApS.

weber.com



WEBER-STEPHEN PRODUCTS LLC
www.weber.com