

ZONELINE[®]

Vertical Series



Engineering Data Manual



GE APPLIANCES
a Haier company

AIR & WATER

SOLUTIONS

Quick Reference

AVE SERIES - FIXED SPEED COOLING w/ ELECTRIC HEAT

| MODEL NUMBER | VOLTAGE | COOLING (BTUH) | EER2 | COOLING WATTS* |
|--------------|---------|----------------|------|----------------|
| AVES09DCXXA | 208 | 8900 | 12.0 | 750 |
| | 230 | 8800 | 12.1 | 735 |
| AVES12DCXXA | 208 | 12500 | 11.7 | 1075 |
| | 230 | 12400 | 11.8 | 1060 |
| AVES18DCXXA | 208 | 17300 | 10.9 | 1585 |
| | 230 | 17200 | 10.9 | 1575 |

AVV SERIES - 230/208V VARIABLE SPEED COOLING w/ HEAT PUMP

| MODEL NUMBER | VOLTAGE | COOLING (BTUH) | SEER2 | COOLING WATTS* | HEAT PUMP (BTUH) | HSPF2 | HEAT PUMP WATTS |
|--------------------|---------|----------------|-------|----------------|------------------|-------|-----------------|
| AVVS12DCXWA (Corr) | 208 | 5200 - 16200 | 17.0 | 1050 | 4500 - 13000 | 8.1 | 915 |
| | 230 | | | | | | |
| AVVL12DMXWA (MUA) | 208 | 5200 - 16200 | 17.0 | 1050 | 4500 - 13000 | 8.1 | 915 |
| | 230 | | | | | | |
| AVVS24DCXWA (Corr) | 208 | 5200 - 24000 | 16.0 | 2515 | 5000 - 23000 | 7.7 | 2360 |
| | 230 | | | | | | |
| AVVL24DMXWA (MUA) | 208 | 5200 - 24000 | 16.0 | 2515 | 5000 - 23000 | 7.7 | 2360 |
| | 230 | | | | | | |

AVV SERIES - 265V VARIABLE SPEED COOLING w/ HEAT PUMP

| MODEL NUMBER | VOLTAGE | COOLING (BTUH) | SEER2 | COOLING WATTS* | HEAT PUMP (BTUH) | HSPF2 | HEAT PUMP WATTS |
|--------------------|---------|----------------|-------|----------------|------------------|-------|-----------------|
| AVVS12ECXWA (Corr) | 265 | 5200 - 16200 | 17.0 | 1040 | 4500 - 13000 | 8.1 | 905 |
| AVVL12EMXWA (MUA) | 265 | 5200 - 16200 | 17.0 | 1040 | 4500 - 13000 | 8.1 | 905 |

Makeup Air is designed to provide continuous outdoor air through the vent door. The unit will adjust to dehumidify the room if the relative humidity is above 50%

* Units not tested per Appendix I - Controls Verification Procedure - Normative or Appendix J - Determination of Cut-in and Cut-out Temperatures - Normative

Full Specs on pages 28-29

All units require a power connection kit

Power connection kit determines resistance heat output

Specifications subject to change



2025 Vertical Nomenclature

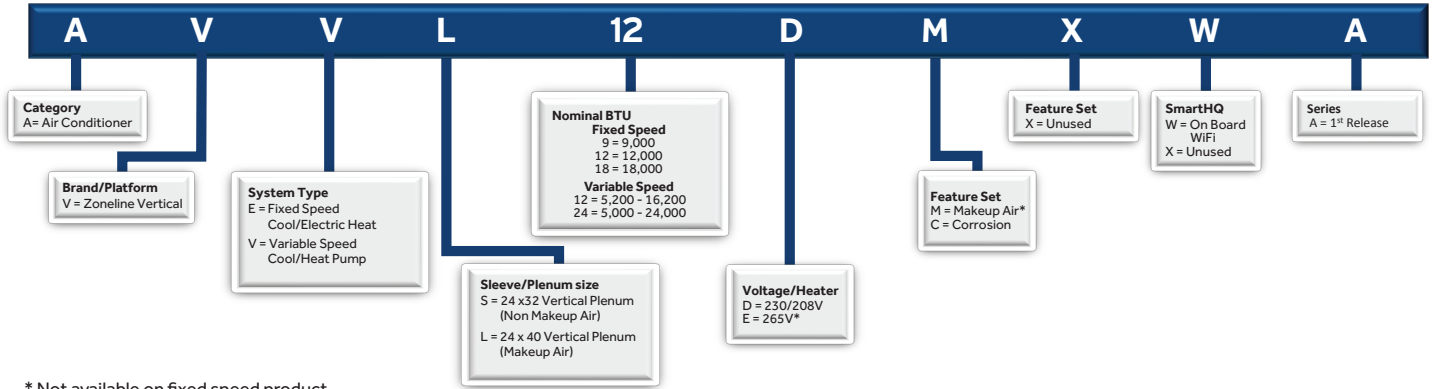

* Not available on fixed speed product

Power Connection Requirements

POWER CONNECTION REQUIREMENTS (RESISTANCE HEAT)

| 230/208 VOLT | 9000 & 12,000 BTU | | | 18,000 & 24,000 BTU * | |
|--------------------------------------|-----------------------------------|-----------------------------------|-----------------------------------|-----------------------------------|-----------------------------------|
| Power Connection Kit | RAK315D | RAK320D | RAK330D | RAK320D | RAK330D |
| Heater BTU | 8,360/6,838 | 11,770/9,629 | 17,060/13,952 | 11,770/9,629 | 17,060/13,952 |
| Total Watts | 2,568/2,122 | 3,568/2,940 | 5,118/4,207 | 3,568/2,940 | 5,118/4,207 |
| Heater Watts | 2,450/2,004 | 3,450/2,822 | 5,000/4,089 | 3,450/2,822 | 5,000/4,089 |
| Total Heating Amps | 10.7/9.6 | 15.0/13.6 | 21.7/19.7 | 15.0/13.6 | 21.7/19.7 |
| MCA | 15 | 20 | 30 | 20 | 30 |
| Recommended Protective Device (MOCP) | 15 Amp Time Delay Fuse Or Breaker | 20 Amp Time Delay Fuse Or Breaker | 30 Amp Time Delay Fuse Or Breaker | 20 Amp Time Delay Fuse Or Breaker | 30 Amp Time Delay Fuse Or Breaker |

* There is no 15 amp breaker option available for the 18K & 24K BTU models due to compliance with UL standard 60335-2-40

POWER CONNECTION REQUIREMENTS

| 265 VOLT | | | |
|--------------------------------------|-----------------------------------|-----------------------------------|-----------------------------------|
| Power Connection Kit | RAK515D | RAK520D | RAK530D |
| Heater BTU | 8,360 | 11,770 | 17,060 |
| Total Watts | 2,568 | 3,568 | 5,118 |
| Heater Watts | 2,450 | 3,450 | 5,000 |
| Total Heating Amps | 9.2 | 13.0 | 18.9 |
| MCA | 15 | 20 | 30 |
| Recommended Protective Device (MOCP) | 15 Amp Time Delay Fuse Or Breaker | 20 Amp Time Delay Fuse Or Breaker | 30 Amp Time Delay Fuse Or Breaker |

Specifications subject to change

Vertical Products

The **GE Zonline Vertical Series**, encompassing the **V12**, **V11**, and **V10** models, represents GE Appliances latest design advancement in Vertical Terminal Air Conditioners (VTACs), designed to deliver superior comfort, efficiency, and ease of installation for applications such as hotels, multifamily residences, and assisted living facilities. Engineered by GE Appliances, a trusted leader in the PTAC industry since 1961, these units combine cutting-edge technology with practical design to meet real-world needs, offering unmatched performance compared to other products in their category.

GE Appliances is **adding the NEW 2-ton vertical units** to the existing lineup, featuring Variable Speed technology and Makeup Air. The Variable speed inverter provides (5,200 – 24,000 BTUs) cooling the maximum space. Using R454B, the 2-Ton series has achieved the latest energy efficiency industry requirements.

The **V12** introduced groundbreaking features, particularly its **Inverter Technology** with a variable speed compressor and **Adjustable Speed Makeup Air** system, delivering 25–70 CFM of conditioned air for enhanced indoor air quality. This model, such as the **AVVL12DMXWA**, boasts a cooling capacity of 12,500 BTUs (5,200–16,200 BTU range) and a heating capacity of 4,500–13,000 BTU range and COP 2 of 3.5 at 47°F. Its **Perfect Control Technology** optimizes cooling, heating, and dehumidification, ensuring energy efficiency and comfort. The V12 uses **R454B refrigerant** (GWP of 467), the most environmentally friendly in its class, and includes a factory-installed makeup air system to replace indoor air in airtight buildings. With up to 12.0 EER2, 17.0 SEER2, and 8.1 HSPF2, the V12 outperforms many competitors in energy efficiency while maintaining quiet operation. The units come standard with features like SmartHQ Wi-Fi compatibility, onboard diagnostics, and three selectable dehumidification levels (depending on model) to ensure precise control for your space.

The **V11 series**, exemplified by models like AVVS12DCXWA, elevates performance with a variable speed inverter compressor, offering a cooling range of 5,200–16,200 BTUs and heating range of 4,500–13,000 BTUs. It achieves a COP 2 of 3.5, with ratings of 12.0 EER2, 17.0 SEER2, and 8.1 HSPF2. Like the V12, the V11's reverse cycle defrost system allows heat pump operation down to 0°F, reducing reliance on electric resistance heat for cost-efficient heating.

Features like SmartHQ Wi-Fi compatibility, onboard diagnostics, and three selectable dehumidification levels ensure precise control and low maintenance. Its corrosion-resistant coils and rust-proof base pan enhance durability, while quiet operation and a compact vertical design make it a preferred choice over bulkier PTACs or window units.

Introduced in 2021 with a fixed-speed compressor, the V10 series—such as the AVES12DCXXA – revolutionized VTAC installation with the Insta-Platform™, reducing setup time by up to 60% compared to traditional units.* This model offers up to 12,500 BTUs for cooling and optional electric resistance heat (2.45–5.0 kW depending on power supply). The V10 emphasizes quiet performance, with 91% of test participants preferring its sound quality over competitors. It includes onboard diagnostics, SmartHQ Wi-Fi capabilities, and a **self-contained drainage system** for simplified maintenance. The V10's use of R454B refrigerant and corrosion-resistant components ensures longevity and environmental responsibility, setting it apart from less efficient competitors.

Why GE Zonline Vertical

The GE Zonline V12, V11, and V10 models outshine competitors due to their innovative installation systems (Insta-Platform™ quick-install plenum), energy-efficient inverter technology, and ultra-quiet operation, making them ideal for guest-focused environments. Their use of R454B refrigerant minimizes environmental impact, while SmartHQ Wi-Fi and onboard diagnostics simplify management and maintenance. Unlike traditional PTACs or window units, the vertical design saves floor space, integrates seamlessly into closets, and supports ducting for multiple rooms. The V12's Makeup Air system and the low-temperature heat pump operation provide unique advantages, ensuring superior comfort and efficiency in diverse climates. These features, combined with GE's legacy of reliability and corrosion protection, make the Zonline Vertical Series the industry's top choice for VTACs.

* Compared to Friedrich Vert-I-Pak models or GEA AZ91 series models, including installing and building a platform.

IMPORTANT NOTICE

Equipment used as a primary source for heating or cooling is an integral part of the building in which it is installed. Proper application is essential for satisfactory performance over a wide range of operating conditions. It is strongly recommended that a professional engineer determine proper application. If the unit is a replacement unit, its specifications and performance may differ from those of the unit it is replacing. For that reason, we again strongly recommend that a professional engineer determine proper application.

Vertical Series Features (V12 - Variable Speed w/Makeup Air model)



Vertical System Features

The Zonline Vertical Series is designed with features* and innovations, making it the ideal unit to own.

- Excellent efficiency and dehumidification
 - Humidity Sentinel (Variable speed product only)
- GE Appliances unique Insta-Platform w/:
 - Self-contained drainage system
 - Fast-connect plumbing
 - Self-aligning lock-in-place system
- Inverter Technology (variable speed product)
- Adjustable Speed Makeup Air (selected models)
- Electronic Controls
 - Auxiliary settings
 - Onboard diagnostics
- SmartHQ™ Wi-Fi Capability
- HIGH and LOW fan speeds controlled by remote thermostat
- Corrosion protection (non MUA models)
- Slinger ring condensate removal
- Indoor frost control
- Automatic compressor random restart
- Compressor restart delay
- Electronic control diagnostics/ Service Modes
- Boost Heat
- Freeze/Heat Sentinel
- Permanently lubricated EC fan motors
- Standard size air filter (18" x 20" x 1") included
- Central desk control or Patio Door capability

* Not all features are available on all units

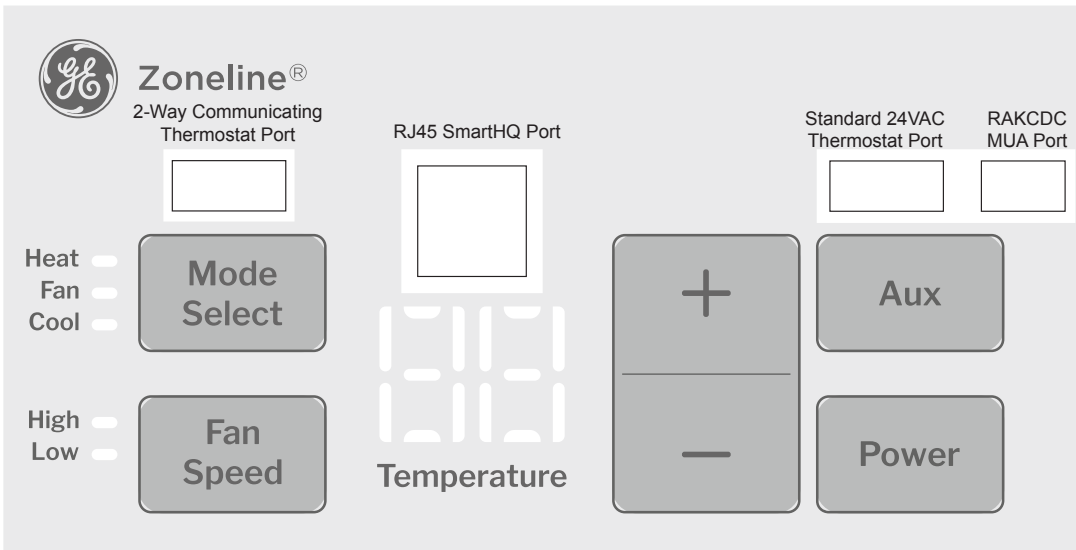

Onboard Electronic Controls

Inverter Technology (V12 and V11 models)

Variable-speed operation provides advantages such as shorter recovery time, improved efficiency, better sound quality, and enhanced dehumidification. Consistent room temperature allows for total room comfort.

Inverter technology enables variable speed operation and improves:

- **Temperature Recovery Time** — ensuring occupant comfort by quickly reaching the desired setpoint temperature
- **Efficiency** — aligns compressor output to room needs thereby reducing energy consumption and temperature control
- **Low Ambient Heat Pump Energy Savings** — the variable speed compressor and advanced defrost capability allows for heat pump operation down to 0° F providing energy savings during the heating season
- **Two-Way Thermostat Capability** — advanced thermostat communication allows for true compressor speed control and adjusts cooling & dehumidification outputs to precisely match room needs
- **Sound Quality** — operates at slower speeds longer and smoothly changes speed to avoid abrupt start-ups
- **Dehumidification** — with 3 selectable levels of enhanced dehumidification, it maintains comfortable room conditions using variable speed to reduce humidity, even in challenging environments



Makeup Air

A dedicated variable speed fan allows for the delivery of room specific volumes of conditioned Makeup air of up to 70 CFM.

The RAK190V thermostat provides the ability to achieve energy savings by cycling Makeup air based on occupancy status.

The RAA13V is an optional MERV 13 filter that reduces dust, pollen, mold, bacteria, viruses and other airborne pathogens from entering the room. It provides cleaner Makeup air to improve overall indoor air quality, with easy access from the front side of unit.

Makeup Air with customizable variable speed fan technology provides 25 to 70 CFM of outside airflow for specific applications. For energy savings, Makeup Air delivery can be cycled based on occupancy, using a compatible occupancy detecting thermostat (e.g. RAK190V).



Features & Benefits

Excellent Efficiency and Dehumidification

GE Appliances recognizes the importance of energy efficiency and dehumidification in an air conditioning system and uses EER2 (Energy Efficiency Rating) or SEER2 (Seasonal Energy Efficiency Rating) as the required means of reporting the relative cooling efficiency of the unit.

The measurement of the efficiency of the vertical heat pump output, when compared to electric resistance heat, is called the Heating Seasonal Performance Factor (HSPF2). The GE Zoneline single packaged vertical heat pump has outstanding HSPF2 ratings. This number provides a measure of the unit's heating efficiency over the season and the ability to directly compare heat pumps within the same range of capacity to one another.

Dehumidification

In addition to efficiently maintaining room temperature, the AVV series intelligently monitors room humidity and offers three selectable levels of advanced dehumidification to target a comfortable room humidity of less than 50% relative humidity (RH). The desired level of dehumidification is selected in the unit's auxiliary control settings. The chart below describes each level of dehumidification and when it will be active.

| Setting AUX b4 | Humidity Sentinel |
|-------------------|---|
| Off | Dehumidification happens as part of the normal cooling cycle. No additional dehumidification efforts taken. |
| Low | When RH is > 50% and unit is running in low speed cooling requests. Adjusts EEVs, indoor fan speed and compressor speed to optimize coil temperature for more dehumidification. |
| Standard | Same as Low cycle but adds 1KW of electric heat when RH is > 70%. |
| High | Same as Standard cycle but adds 1KW of electric heat when RH is > 60%. |

NOTE: The default settings for Aux b4 is OFF for non-MUA models and Standard for MUA models. Use of the Standard or High settings will likely result in increased energy consumption.

Permanently Lubricated EC Fan Motors

The Zoneline Vertical chassis has two permanently lubricated, totally enclosed fan motors. The motors are permanently lubricated to reduce maintenance, and totally enclosed to keep dirt and water out of the motor windings. These motors are of the EC type for precision speed control and efficient performance.

Central Desk Control (CDC)

The Vertical Series is compatible with simple on/off 2-wire Central Desk Control (CDC) systems or patio door monitoring. The unit utilizes a 3 pin port to interface such a system. This requires the separate purchase of the RAKCDC connector accessory. The most common installation of this type of system is a switch mounted at the registration desk; and, upon guest check-in, the switch is activated to allow the air conditioner to operate.

At some locations this feature is used with a normally open switch connected to a sliding glass door. Opening the door causes the contact to close and thus turns off the air conditioning. This prevents the unit from running and wasting energy with the sliding glass door open.

In some older cases this type of system is used with a "switch board" at the registration desk. Upon guest registration, the switch is activated to allow the air conditioning to operate.

Likewise, when the guest checks out, the device is switched to the "OFF" setting so the unit will not operate when the room is not rented.

Nowadays, occupancy sensing thermostats have replaced many of the front desk systems.

Important CDC Notes:

1. The unit requires the use of a normally open switch. Closing the circuit shuts off the system.
2. Both wires comprising the circuit must connect to the CDC terminals on the unit and to the controlling switch. Do not use a common bus (at the unit or at the switch panel) in the wiring.
3. A 24-volt transformer is contained within the Zoneline Vertical Unit. No external voltage may be applied to the unit through the CDC terminals.
4. Minimum wire size for CDC wiring:

| WIRE SIZE # AWG | MAXIMUM ALLOWABLE LENGTH |
|-----------------|--------------------------|
| #22 | 600 Ft. |
| #20 | 900 Ft. |
| #18 | 1,500 Ft. |
| #16 | 2,000 Ft. |

5. Freeze Sentinel and Heat Sentinel still remain operational when the unit is connected to a CDC system.

CDC Typical Wiring

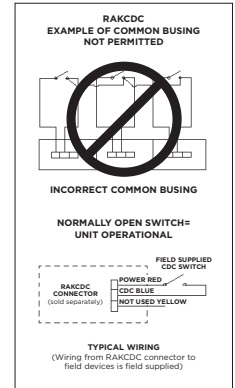

CDC Port Location

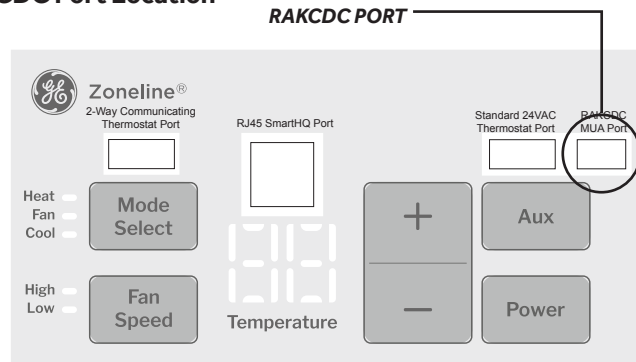

Indoor Coil Frost Control

Under certain operating conditions, frost can form on the indoor coil of an air conditioner, reducing air flow and cooling. In order to prevent frost from forming, the Zoneline Vertical chassis has an automatic frost control on the indoor coil. If frost begins to form on the coil, the compressor stops while the indoor fan continues to run, until the coil temperature increases and the frost dissipates.

At that time, the compressor resumes operation and cooling continues. The indoor fan remains running during the time the compressor is off to help warm the coil with room temperature air.

Features & Benefits

Higher CFMs tend to increase the operating sound level, both from fan noise and from air noise in the duct. Higher CFMs also reduce the dehumidification rate of the unit, while lower CFMs provide quieter operation and better dehumidification. However, if the CFMs are not high enough to adequately move the air through the duct system, the unit will not be able to provide a comfortable room. For fixed speed units, the fan speed is constant. For variable speed units, the fan speed will vary to complement the speed of the compressor.

If the Zoneline Vertical chassis is connected to a wall thermostat without the ability to provide two fan speeds, the fan speed will be determined by connecting the wire controlling the fan to the low or the high-speed fan terminal on the unit.

FIXED SPEED MODELS

| ESP (in. water) | Indoor Fan CFM | | | | |
|--------------------|-------------------------|---------|----------|---------|-----|
| | Fan Boost Mode (AUX A7) | | | | |
| | ON | | OFF | | |
| | High Fan | Low Fan | High Fan | Low Fan | |
| AVES09 | 0.10 | 482 | 420 | 420 | 340 |
| | 0.15 | 466 | 402 | 402 | 306 |
| | 0.20 | 453 | 368 | 368 | 266 |
| | 0.25 | 416 | 332 | 332 | 152 |
| | 0.30 | 384 | 277 | * | * |

* Do not operate in these conditions

Airflow values measured in Fan mode at room temperature

| ESP (in. water) | Indoor Fan CFM | | | | |
|--------------------|-------------------------|---------|----------|---------|-----|
| | Fan Boost Mode (AUX A7) | | | | |
| | ON | | OFF | | |
| | High Fan | Low Fan | High Fan | Low Fan | |
| AVES12 | 0.10 | 535 | 447 | 447 | 412 |
| | 0.15 | 521 | 429 | 429 | 394 |
| | 0.20 | 505 | 403 | 403 | 357 |
| | 0.25 | 494 | 370 | 370 | 320 |
| | 0.30 | 456 | 338 | 338 | 258 |

Airflow values measured in Fan mode at room temperature

| ESP (in. water) | Indoor Fan CFM | | | | |
|--------------------|-------------------------|---------|----------|---------|-----|
| | Fan Boost Mode (AUX A7) | | | | |
| | ON | | OFF | | |
| | High Fan | Low Fan | High Fan | Low Fan | |
| AVES18 | 0.10 | 643 | 545 | 545 | 438 |
| | 0.15 | 624 | 529 | 529 | 420 |
| | 0.20 | 612 | 514 | 514 | 390 |
| | 0.25 | 600 | 504 | 504 | 357 |
| | 0.30 | 590 | 468 | 468 | 327 |

Airflow values measured in Fan mode at room temperature

Indoor Fan Speed Ranges

The Zoneline Vertical chassis is designed to discharge into one or more rooms. Depending on the size of the space, different fan speeds could be required to properly move the air and heat/cool the rooms. With that in mind, the vertical series is equipped with 2 fan speed ranges.

Each range will have a "low" and "high" fan speed to help meet the space and duct design and provide the necessary air movement. **GE Appliances recommends an HVAC engineer be consulted to determine the best fan speed for the application.**

VARIABLE SPEED MODELS

| ESP (in. water) | Indoor Fan CFM | | | | |
|--------------------|-------------------------|---------|----------|---------|-----|
| | Fan Boost Mode (AUX A7) | | | | |
| | ON | | OFF | | |
| | High Fan | Low Fan | High Fan | Low Fan | |
| AVV12 | 0.10 | 535 | 473 | 433 | 382 |
| | 0.15 | 521 | 457 | 416 | 357 |
| | 0.20 | 505 | 444 | 385 | 320 |
| | 0.25 | 494 | 405 | 350 | 271 |
| | 0.30 | 456 | 372 | 313 | 166 |

Airflow values measured in Fan mode at room temperature

| ESP (in. water) | Indoor Fan CFM | | |
|--------------------|----------------|---------|-----|
| | High Fan | Low Fan | |
| AVV24 | 0.10 | 726 | 648 |
| | 0.15 | 704 | 628 |
| | 0.20 | 688 | 617 |
| | 0.25 | 680 | 605 |
| | 0.30 | 669 | 594 |

1. Airflow values measured in cool mode
2. Fan Boost provides similar output but reaches it sooner in the compressor rampup
3. If ESP > 0.2, use Fan Boost"

Corrosion Protection Treatment—Standard



- Painted Outdoor Fan Motor Casing
- Double Painted Compressor
- Coated Outdoor Coils With Stainless Steel End Brackets
- Durable Composite Base Pan

NOTE: Makeup Air models are not recommended for installation within two miles of coastal areas.

Features & Benefits

Automatic Compressor Random Restart

In the event of a power interruption, all compressors attempting to restart immediately when power is restored can result in a power surge that can cause another power failure. The microprocessor in the Zoneline Vertical chassis has a random restart logic system that prevents all compressors from restarting at the same instant.

Slinger Ring Condensate Removal

Condensate water removed from the indoor air is dispersed into the outdoor air stream by the outdoor fan slinger ring and deposited on the hot outdoor coil. The water helps cool the refrigerant in the outdoor coil and increases the efficiency of the air conditioner, while reducing the condensate draining from the unit.

Compressor Restart Delay

Zoneline Vertical units are designed to provide a minimum of three minutes of compressor off time to allow refrigerant pressures to equalize before attempting to restart. Attempting to restart against a high head pressure shortens compressor and overload protector life.

The units are also designed to provide a minimum of three minutes of compressor run time to prevent short cycling from disturbing the room occupant.

Freeze Sentinel

- Detects low room temperature and turns heater to help protect against damage caused by freezing room temperatures.
- The electric heater turns on at 41°F and warms the room up to 46°F and shuts off.
- Freeze Sentinels may be turned off via the auxiliary controls.

Heat Sentinel

The property owner may choose to activate the Heat Sentinel feature on the Zoneline unit. If the Heat Sentinel is activated and room temperature reaches 85°F (even when the unit is in the "OFF" mode), the unit will automatically start the air conditioning operation and will shut off when the room temperature reaches 80°F. This will help dehumidify the air and lower high temperatures so the guest will not be entering an extremely hot room.

Heat Pump Operation

Heat pumps save money compared to electric resistance heat, but if the unit cannot provide room occupant comfort, the savings may be of questionable benefit. GE Appliances has years of experience with designing Zoneline heat pumps to solve the problem of guest complaints.

The variable speed heat pump units use a three-stage heat (including auxiliary heat)/two-stage cooling thermostat, while the fixed speed units use a two-stage heat/one-stage cool, and will operate as specified by the remote thermostat being used as long as outdoor conditions will allow. If the remote thermostat asks for heat pump heating outside of unit heat pump operating conditions, the heating request will be met by utilizing back-up resistance heat.

The Variable Speed Zoneline Vertical chassis will operate in efficient heat pump mode down to a 0°F outdoor temperature, while the Fixed Speed series will operate in heat pump mode down to a 25°F outdoor temperature. At temperatures below those listed above, the units will automatically switch to electric heat.

The resistance heater and the heat pump do not operate simultaneously.

Heat Pump Logic

The chart below indicates the standard heating source of the vertical series heat pump models under various outdoor conditions. The unit is designed to provide heat pump savings without sacrificing room comfort.

AVV - VARIABLE SPEED SERIES

| Heat Setting Configuration | | Outdoor Temperature | |
|---------------------------------|--------------------------|-----------------------------|----------------------|
| All Electric Heat Mode (Aux A8) | Heat Boost Mode (Aux A9) | >~3°F | ≤ 0°F |
| OFF | OFF | Y1 (or Y2) Heat Pump | Full Resistance Heat |
| OFF | ON | Y2 Heat Pump+ 1KW Elec Heat | Full Resistance Heat |
| ON | OFF/ON | Full Resistance Heat | Full Resistance Heat |

AVE - FIXED SPEED SERIES

| Heat Setting Configuration | | Outdoor Temperature | |
|---------------------------------|--------------------------|--------------------------|----------------------|
| All Electric Heat Mode (Aux A8) | Heat Boost Mode (Aux A9) | >~35°F | ≤ 25°F |
| OFF | OFF | Heat Pump | Full Resistance Heat |
| OFF | ON | Heat Pump+ 1KW Elec Heat | Full Resistance Heat |
| ON | OFF/ON | Full Resistance Heat | Full Resistance Heat |

*Simultaneous supplemental heat (Boost Heat):
1.0KW @ 230V & 265V; 0.8kW @ 208V

Heat Pump Defrost

Zoneline heat pumps utilize a reverse-cycle, demand-defrost system to extend heat pump operation and increase savings from extended operation. The microprocessor determines the need for defrosting from criteria based on continuous compressor running time, outdoor air temperature and outdoor coil temperature. When defrosting is required, the unit reverses the flow of refrigerant to direct the hot gas into the outdoor coil to melt the frost buildup.

Boost Heat

The vertical series offers a Boost Heat option feature that utilizes partial supplemental resistance heat at the same time as the heat pump operation. The boost heat feature changes stage one and stage two heating (heat pump) to be heat pump with partial resistance heat. Stage three heating stays as full resistance heat.

NOTE: Heat Pump and full resistance heat shall never be on at the same time.

Electronic Control Diagnostics/Service Mode

The Zoneline Vertical system continuously monitors the unit operation and in some cases the unit may take action and shut down until conditions are corrected. The electronic control will store/provide Error Codes to aid in diagnosis and correction to get the unit up and running quickly. In addition to error codes, the unit is equipped with Service Modes that allow for independent testing of unit functionality. This allows for fan, heat, cool operations among other checks to be "forced" without signals from the remote thermostat or unit temperature sensors. This is a valuable tool that helps pinpoint operational problems and also helps distinguish unit malfunction from problems caused by remote thermostat. See the product Use & Care/Mini-Manual for specifics on Error Codes, Service Modes, and how to use the system.

Features & Benefits

On-Board (Integrated) Wi-Fi SmartHQ™

SmartHQ™ Management is a modern subscription platform designed to transform operations for better property asset management. It offers a range of features that help hospitality operators, property managers, and facility managers to remotely monitor, control, and update products across multiple properties or units.

With the built-in SmartHQ Connect module on both our Fixed Speed and Variable Speed Vertical products (along with a Wi-Fi connection); property managers and technicians can use SmartHQ Management (and SmartHQ Service) to provide advanced diagnostics and management tools to optimize product performance and reduce downtime.

Here are some key aspects of SmartHQ Management:

- **Remote Monitoring and Control:** Users can remotely monitor and control products, ensuring they are functioning optimally and addressing any issues promptly.
- **Energy Consumption Insights:** SmartHQ Management offers insights into energy consumption, helping users drive sustainability and cost control.
- **Task Management:** The platform streamlines task management for maintenance and service teams, ensuring efficient operations.
- **Batch Command:** Users can remotely batch command units' temperature settings, power on or off, and manage units by building, floor, or individual units.
- **Advanced Diagnostics:** The platform includes advanced diagnostics to eliminate service guesswork with precision diagnostics and even order parts directly at the point of service.
- **API Integration:** SmartHQ Management seamlessly interacts with preferred management systems and creates custom workflows to meet team needs.

Wi-Fi Network Requirements for GE SmartHQ

All Wi-Fi enabled Zoneline products work seamlessly with the SmartHQ™ Management platform to connect and control your products.

To connect GE Appliances to SmartHQ, the hotel's Wi-Fi must adhere to these specifications:

- **Frequency Band:** 2.4 GHz only (5 GHz is not supported).
- **Security Protocol:** WPA or WPA2-PSK (pre-shared key, i.e., a simple passphrase). WPA3, WPA2-Enterprise (common in business networks for user authentication), and open networks are not supported.
- **Authentication:** No captive portals allowed - the network must permit direct connection without redirecting to a login page.
- **Signal Strength:** At least -50 dB at the unit's location for reliable connectivity.

- **Firewall and Ports:** The network must allow outbound traffic on these ports without blocking or proxying.
- **Other:** IPv4 only (no IPv6), no proxy servers, no HTTP redirects, and the ability to maintain a persistent TCP connection 24/7.

These requirements ensure secure, reliable communication between the unit and GE's cloud servers for SmartHQ features. GE Appliances achieve a high IoT security rating (UL Gold level), but the network setup is critical to avoid disruptions.

Smart HQ Service

All GE Appliances Zoneline products are compatible with the SmartHQ Service module. SmartHQ Service is a subscription application which enables smart diagnostics, software updates, service documentation, service training, and more.

- **Diagnostics & Service Mode** – Servicer can plug in and connect to their mobile device to view various diagnostic, including fault codes and various service readings like fan speeds and temperatures, and perform service mode procedures to evaluate and diagnose issues, directly with the product.
- **Model & Serial information** – Connecting with the product gives model and serial information, run time and manufacture date.
- **Service & Product Documentation** – SmartHQ Service app provides service manuals and other documentation helpful to repair.
- **Parts Look up** – Get schematic views with part numbers to quickly identify and select the right parts to keep your units running smoothly.
- **Training resources** – Additional helpful content is available to help.

For more information on these connected options please visit www.smarthqpro.com

Components & Installation

Each Zoneline single packaged vertical unit requires a drain platform, wall plenum, exterior grille, unit, remote thermostat, filter and a return air grille, ductwork and supply registers.

The legs for the drain platform, ductwork and supply registers are field supplied. Each of the other components is ordered separately. The drain platform, wall plenum and exterior grille are specifically designed to interface with the GE Appliances Zoneline Vertical chassis and must be purchased from the same source as the unit. Custom exterior grilles may be used but must comply with the requirements shown on page 13.

The remote thermostat and the return air grille are offered as accessories by GE Appliances, but may be purchased from a source other than GE Appliances. If a non-GE Appliances thermostat is being used, it should meet the general thermostat requirements mentioned on pages 15 and 24. Any custom return air grille being used should offer a louvered area as large as the GE Appliance offering or larger.

Wall Plenum

Since the unit itself does not install in the wall opening, the use of a plenum is necessary to contain and separate the air paths. The plenum must be able to hold water in the bottom without leaking into the wall cavity. It also must have a "splitter" to separate the outdoor air paths and prevent the discharge air from being drawn back into the unit.

The wall plenum is the first component to be installed. GE Appliances plenum, RAVWPT15B (for makeup air models) is available for use with wall thicknesses of 8" to 15."

The plenum is to be installed square and level in the opening and secured to the wall construction with screws or nails in the sides located a minimum of 2" up from the bottom of the plenum. No nails or screws may be used in the bottom or top of the plenum to prevent water entering the wall cavity.



**Wall Plenum
(for Makeup Air models)
RAVWPT15B
Cutout:
24"W X 40"H**

The plenum is not load bearing, so a proper header needs to be installed above the plenum the same as over any window opening in the wall. If the building construction is brick, concrete block or other non self-supporting material, a lintel must be installed over the plenum opening. The plenum must be caulked to the wall, both to the outdoor wall face and to the interior wall, along all four sides to prevent air and water infiltration.

Drain Platform

The Vertical Series requires the use of a separate drain platform accessory (RAVDPLAT). This accessory supports the chassis and positions it properly to seal to the wall plenum. Secondly, it serves as the drain pan for the chassis with connections for both a primary and secondary drain. This innovative accessory saves time and money by eliminating the need for field fabricated support platforms. It also greatly simplifies chassis removal from the closet because the plumbing connections are made to the platform as opposed to the chassis itself.

The drain platform height is determined based on the position of the Zoneline Vertical wall plenum. The bottom edge of the drain platform is flush with the bottom edge of the plenum. Technically, the bottom edge could be set to floor level, but that would likely make connecting to a building drain system difficult. In most installations, it is desired to raise the platform several inches off the floor. This can easily be done using 2"x4" lumber cut to length and positioned in the integrated support pockets of the RAVDPLAT. Only two support legs are needed as the rear side of the platform is attached and supported by the wall plenum.

The primary drain can be directed out either side or the front of the drain platform (through notches in the platform). If the platform is elevated for drainpipe clearance below, the primary drain can run any direction desired. The secondary drain is to be piped through the wall plenum to the exterior of the building.

For further detail, please see the RAVDPLAT Installation Instructions.

Components & Installation

Standard Size Air Filter

A number of filters, providing varying degrees of filtering efficiency, are available on the market today. GE Appliances has designed the Zonline Vertical chassis to accommodate a number of filter placement options. The filter provided with the unit is a standard size 18" W x 20" H x 1" D filter.

The unit must not be operated without a filter in place, even during construction.

GE Appliances provides three filter placement options for design and installation flexibility. Filter brackets are provided on the front of the Zonline vertical unit chassis (18" x 20" x 1"), which allows for the filter to be directly mounted to the unit (best option). The access panel, accessory model RAVRG4, for the closet enclosure, is the second filter placement option (20" x 24" x 1 to 2"). The access panel requires a cutout in the unit closet enclosure wall and provides access to the unit for servicing and removal. The bottom of the access panel should be at least 1" below the top edge of the drain platform to allow for easy removal of the Zonline Vertical Unit.

The third filter placement option is incorporated in the return air grille-RAVRG2. A 20" x 20" x 1" filter fits inside the grille. The RAVRG2 can be installed in a solid closet access door or in a closet side wall. A 20 3/8" x 20 3/8" cutout in the closet wall or door is required to install this option.

A different size filter may also be used in a field-supplied frame installed in a return air grille mounted in the closet enclosure door or wall.

Only one filter is to be used in the installation. Multiple filters will reduce the air flow and affect unit performance. A clean filter is essential to efficient unit operation.

The filter should be checked at least every 30 days and replaced if dirty



GRILLE
(for Makeup Air models) RAVAL4

Outdoor Clearances

Since the GE Zonline Vertical chassis is an air exchange system, it is critical that the exterior grille, which provides both intake and exhaust, not be covered or impeded in anyway.

Small or minor obstacles, such as poles or small shrubs, should be a minimum of two feet away (radius in all directions). Larger obstructions, such as a solid fence/wall and heat generating sources, like a condensing unit, should be kept away a minimum distance of six feet.

Exterior Grille

The architectural louver exterior grille is mounted to the exterior of the plenum and held in place with four screws inserted from inside enclosure closet. The grille is designed specifically for use with the Zonline Vertical chassis, and **the use of any other grille must be approved by GE Appliances Air Conditioning Applications Engineering.**

Exterior Architectural Treatments And Special Outdoor Grilles

The architectural design of a building may dictate the use of special or oversized louvers for aesthetic reasons. Louvers other than standard Zonline exterior grilles may be used on the Zonline unit, however, these special louvers, or any special exterior architectural treatments of the building facade that may restrict the free circulation of condenser airflow, should be referred to GE Appliances Application Engineering for evaluation and approval. The following guidelines should be followed in selecting a louver:

1. The louver must have a minimum of 65% free area. ASHRAE defines "free area" as the minimum area of the opening in an air inlet or outlet through which air can pass. Percent (%) free area equals the X dimension divided by the Y dimension. (See examples below).
2. The louver should be attached to the wall case in a manner that will prevent recirculation of condenser discharge air into the air inlet. If the louver is not attached directly to the wall case, a field-supplied splitter or gasket is required between the chassis and the louver to prevent recirculation.

It is important that the above criteria be followed since a louver that is too restrictive or allows recirculation will reduce the unit's capacity and efficiency, increase the electrical current draw, cause intermittent operation due to the compressor overload protector shutting the compressor off, and cause failure of the compressor overload protector and shorten compressor life. Using the unit with a grille that is too restrictive or allows recirculation may constitute improper installation and will void the unit's warranty. Since the Zonline unit complies with Underwriters Laboratories® requirements, it may be necessary to send a full size sample louver section to an independent lab to be tested with the Zonline unit.

SAMPLE CALCULATIONS

$$\text{Free Area (\%)} = \frac{X}{Y} \times 100 \quad x = 1" \quad y = 1.5"$$

$$\text{F.A. \%} = \frac{1}{1.5} \times 100 = 66.7\%$$

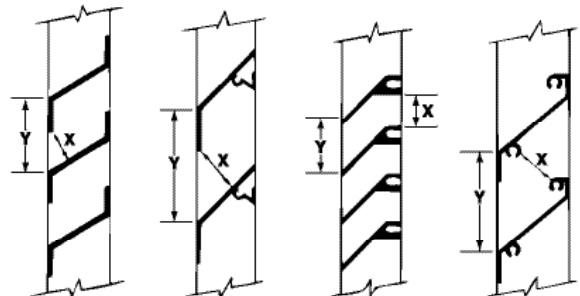

Components & Installation



Return Air Grille, Access Panel Or Louvered Closet Door

The return air from the room to the unit may enter the closet through one of four ways.

A louvered door may be installed on the closet to allow return air to enter. When a louvered door is used, the filter would be installed in the filter bracket on the front panel of the unit.

A wall-mounted access panel may be used instead of a louvered door. The return air is through the access panel, model RAVRG4, which requires a 28 1/8" W x 55 7/8" H cutout in the wall, and there is a filter bracket behind the grille louvers.

A return air grille, model RAVRG2, may also be used and is designed to be installed in a 20-3/8" by 20-3/8" cutout in a flush closet door or closet sidewall. In this installation, a filter can fit into the bracket in the RAVRG2.

A field-supplied return air grille, with a minimum dimension of 20" W x 20" H, may be used if mounted in a cutout in the door or wall. When employing this method for return air, the filter is installed in the bracket mounted on the unit.

Unit And Installation Notes

The unit is a one-piece package system that fits directly into a closet enclosure. Once the drain platform (RAVDPLAT) has been installed, the chassis can be positioned on the drain platform and pushed towards the exterior wall until to "locks" in place. The chassis will drop down slightly onto the platform, securing it in place and engaging the gasket on the wall plenum. Power, thermostat, and duct connections can then be made.

A 10" diameter flange on the top of the unit is used to connect to field-supplied, insulated, flexible or rigid transition duct with an adjustable ring clamp.

Flexible duct may be used for transitions only. Rigid duct must be used for 90-degree bends and tees. Do not use flexible duct for unsupported runs of five feet or more.

Power Connection Kit

All Vertical Series Units are equipped with universal heaters that are capable of different heater outputs. Heater output is determined by which unique direct connect power kit is being used. This increases the flexibility of a chassis where various heating requirements may need to be met at a site. This power connection is the only means of supplying power to the chassis. Please reference the chart on pages 3 and 29 to determine the appropriate power connection kit for your project.



RAVRG2



RAVRG4

Components & Installation



Remote Thermostat

Zonline Vertical units are controlled by a wall-mounted thermostat. Variable speed units are capable of operating with a standard 24VAC thermostat having 2 stage heat pump with aux heat

& 2 stage compressor cooling. Additionally, the unit is capable of operating in a two-way communication mode (available with the RAK190V thermostat). Two-way communication will enable even greater precision in temperature and humidity control by providing the AVV (variable speed compressor) with exact temperature and relative humidity readings from the thermostat.

For two-way communication, low voltage connections are made via the 4 pin connector included with each unit. The harnesses allows for a single point thermostat connection to simplify chassis removal and reinstallation. See diagrams below for terminal designations. For a standard thermostat connection, low voltage wiring connections are made to the 8 pin harness included with each unit.

If a non-GE Appliances thermostat is used, the compatibility of the thermostat with the unit is the responsibility of the installer. The unit has an integral transformer, and no external voltage or transformer may be used.

Maximum wiring length and wire size: AWG 18 up to 66 feet—AWG 20 up to 66 feet.

Ductwork & Supply Registers—Field Supplied

Ductwork and supply registers are mentioned here as System Essential Components, because they are necessary to complete the installation. These components are field supplied per the HVAC engineer's design. Under no circumstances should the Vertical unit be operated to an external static pressure (ESP) in excess of 0.3" W.C.

Please reference the charts on page 9 to determine actual airflow for a given ESP and fan selection. Low CFM selection is our recommendation. Higher CFM levels tend to increase sensible capacity, enhance room circulation and increase duct noise. Lower CFM levels tend to increase latent capacity and reduce noise.

Electrical Information—General

Zonline Single Packaged Vertical Units are to be connected to a single-phase 60 hertz power. Units with the voltage designator "D" in the 7th character of the model number may be operated on either nominal 230-volt or 208-volt power. Units with the voltage designator "E" in the 7th character of the model number are to be operated on nominal 265-volt power (A.K.A. 277-volt power). For all installations, feeder, sub-feeder, branch circuit and electrical protective devices must conform to all local codes. In the absence of a local code, the National Electrical Code should be followed.

Each unit should be installed on a single branch circuit. More than one unit per branch circuit is not recommended. All wiring, must conform to local electrical regulations and codes. When in doubt, consult the National Electrical Code.

Thermostat Connector Wiring

8-Pin

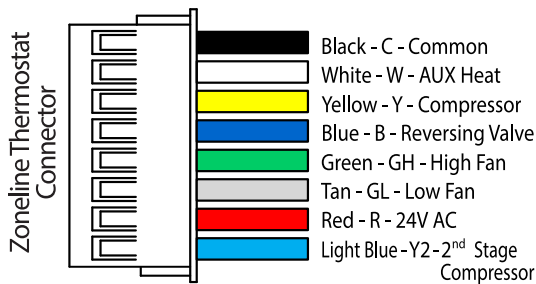

4-Pin

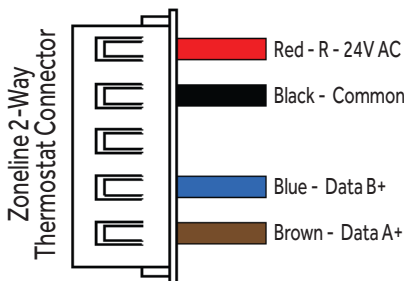

Makeup Air Unit Utility Closet Dimensions

(for reference only)

Important: Plan and locate plenum, drains and thermostat cable carefully to avoid interference. Hard-to-reach locations will make installation and service difficult!

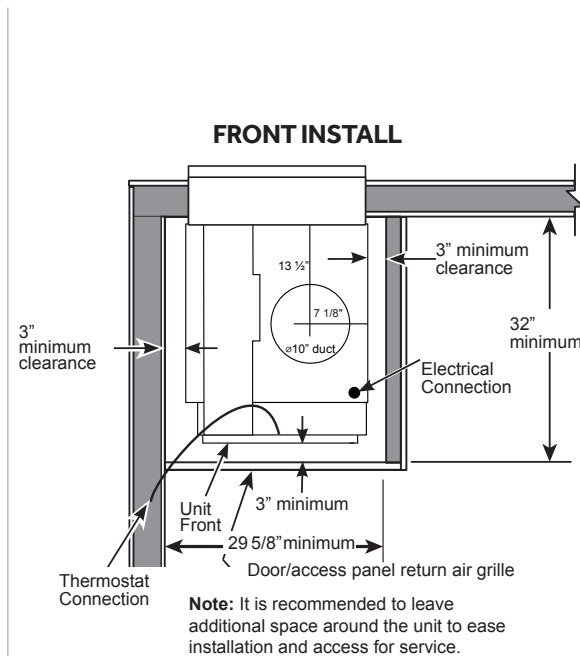
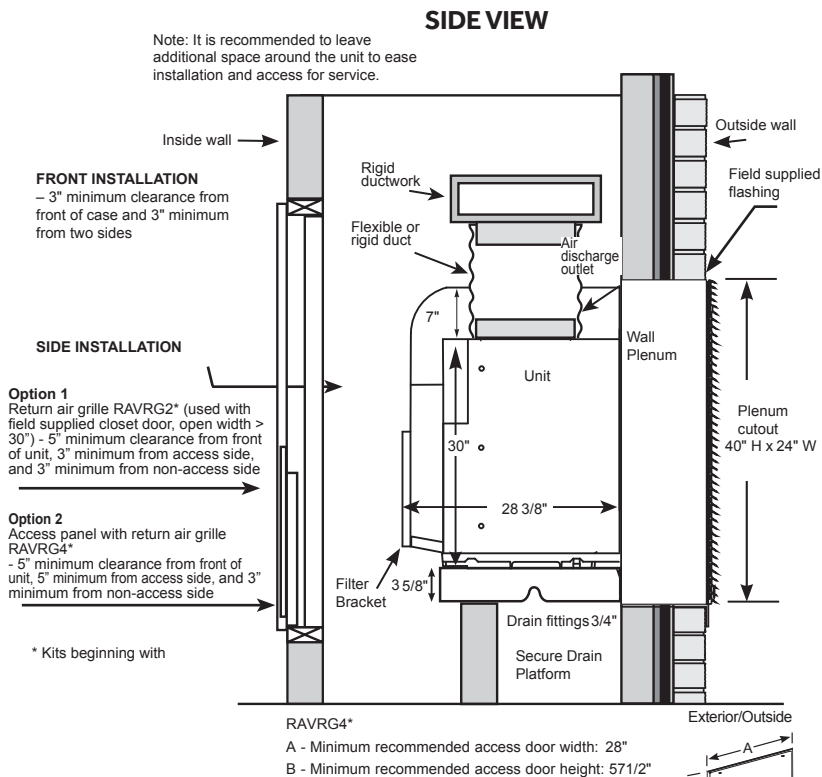

SIDE INSTALL Option 1 (RAVRG2B in Door or Closet Wall)

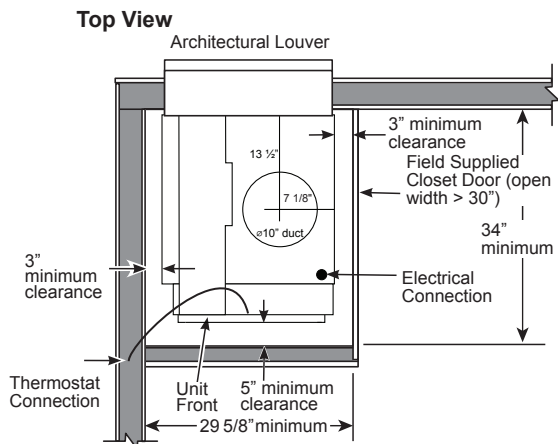

NOTE: Clearance and minimum dimensions are from interior walls of closet

*All variations beginning with this model number

AVAILABLE ACCESSORIES

- Drain Platform-RAVDPLAT
- Architectural Louver—RAVAL4
- Wall Plenum—RAWPT15B—telescopes from 8" to 15"
- Access Panel with Return Air Grille—RAVRG4
- Return Air Grille—RAVRG2
- Wall Thermostat

SIDE INSTALL Option 2 (RAVRG4*)

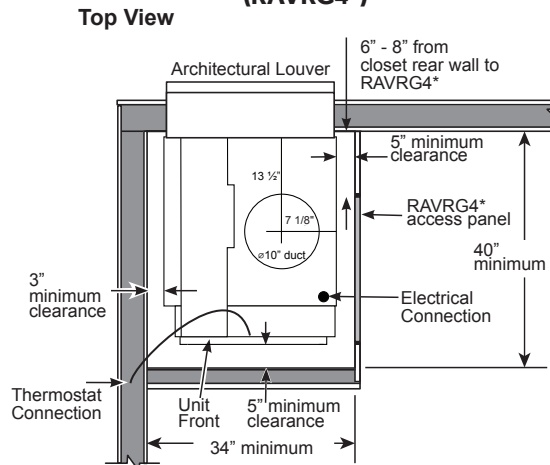

For RAVRG4*: After installing RAVDPLAT per instructions, slide rear of unit through RAVRG4* and rest it on platform in the closet. Rotate unit 90° so that rear of unit is facing the wall plenum. Follow remaining instructions for installing unit to wall plenum.

Non-Makeup Air Unit Utility Closet Dimensions (for reference only)

FRONT INSTALL

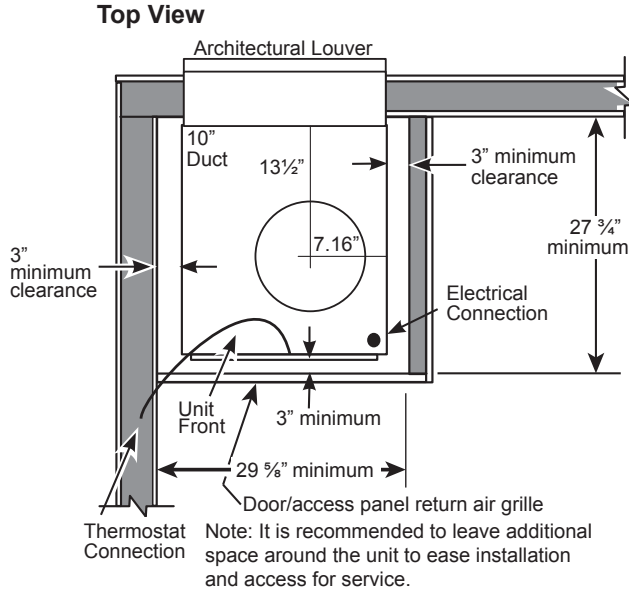

SIDE INSTALL

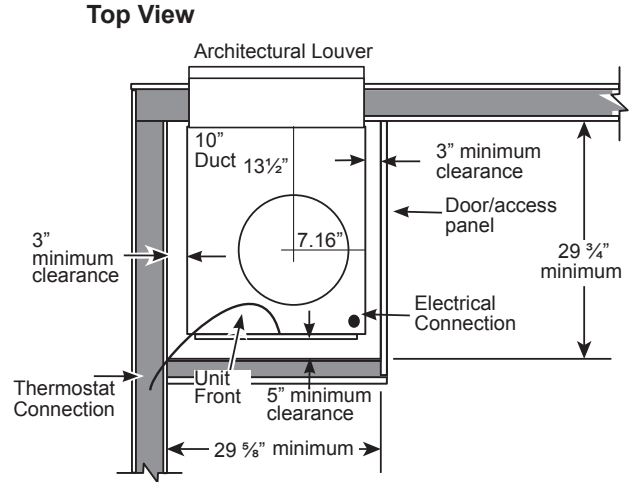

Side View

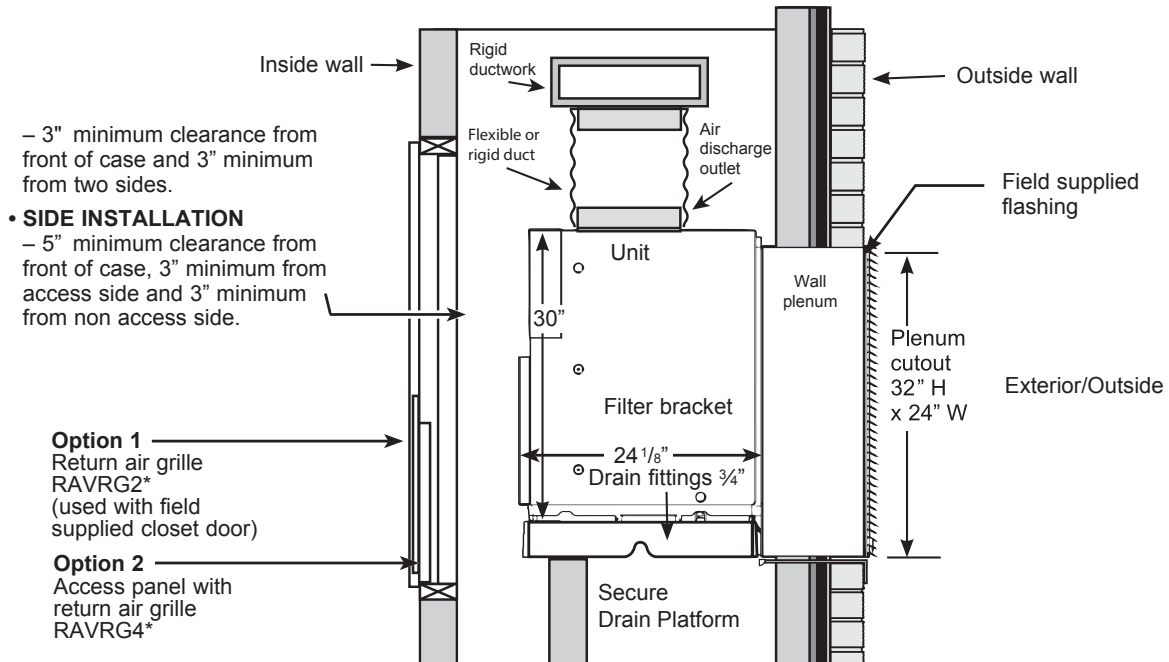

*All variations beginning with this model number

AVAILABLE ACCESSORIES

- Insta-Platform™—RAVDPLAT
- Architectural Louver—RAVAL3
- Wall Plenum—RAVWPT15—telescopes from 8" to 15"
- Access Panel with Return Air Grille—RAVRG4
- Return Air Grille—RAVRG2
- Wall Thermostat

Auxiliary Controls

Auxiliary Controls – Aux Set Button

The electronic control for the unit comes preset from the factory to control the unit how most customers would prefer. The preset modes or functions can be modified to meet the needs of your situation.

If the owner or contractor modifies the auxiliary controls, the owner/contractor is responsible for ensuring the auxiliary controls are set to the proper/desired functions.

To change operating or set up parameters, the system must be in the AUX mode.

With power applied to the unit, press the **AUX** button and “AI” will appear on the display.

Use **+ or -** to navigate through the various AUX options.

Press the **Fan Speed** button to enter the desired Aux setting.

Press the **+ or -** button to change the setting. Some settings will use the **Mode Select** button for additional selection options.

Press the **Fan Speed** button to exit the current Aux setting and return to the Aux Menu.

Settings are applied or locked in when the Fan Speed, Aux, or Power buttons are pressed.

Press the **Aux** or **Power** button to exit the Aux setting mode and return to normal operation

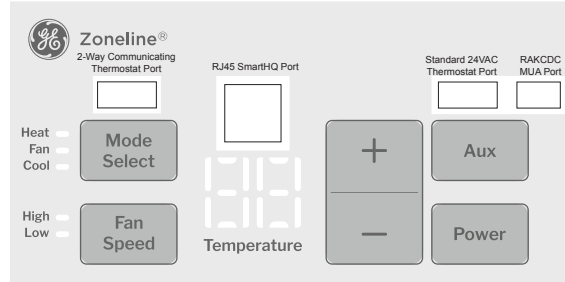

AUX A1 Smart Fan – Cooling/Heating

Smart Fan sets how the fan operates when in the cooling mode and heating modes. Do you want the fan to run continuously regardless of whether the unit is heating or cooling? Or do you want the fan to only operate when the system is heating or cooling (the fan cycles on and off with the cooling or heating operations).

Most customers prefer to keep the fan continuously running when in the cooling mode. This movement of air helps keep the customer comfortable during the off cycles.

Whereas in heating, no one wants the fan blowing air when the unit is not heating.

The **default** settings for **Aux A1** is as follows:

Heating: Cycle (CY)

Cooling: Continuous (Co)

***Note:** In cyclic operation, the indoor fan will activate occasionally to verify the air temperature in the room (not applicable for 2-way connected thermostat operation). If using a 24V external thermostat, these settings do not apply.

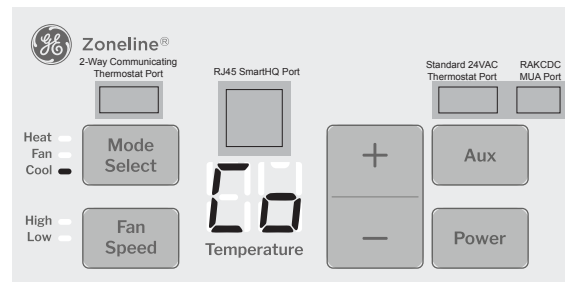
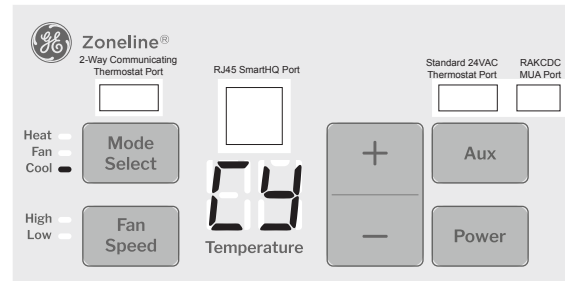
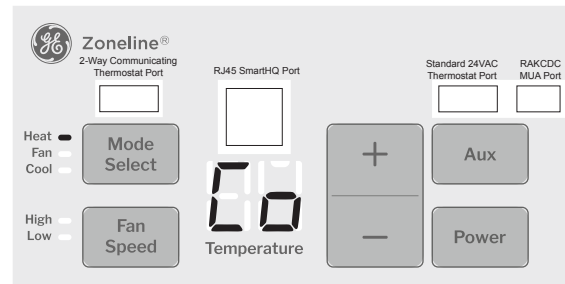
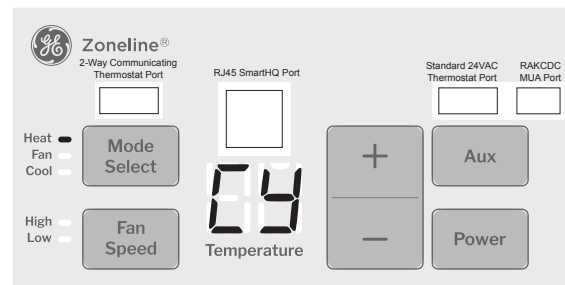

Auxiliary Controls

AUX A2 Fahrenheit/Celsius

This feature allows the unit to display the temperature in either degrees Fahrenheit or Celsius

The **default** setting for **Aux A2** is **Fahrenheit**



AUX A3 Freeze Sentinel/Heat Sentinel

This feature monitors the indoor temperature and automatically turns on the unit to prevent temperature extremes.

As long as there is power to the unit, the sentinel system heats or cools even if the unit is "turned off."

The **default** setting for **Aux A3**:

Heat Sentinel: OFF

Freeze Sentinel: ON

With the **Heat Sentinel** feature "turned on", the unit automatically provides cooling (without user interface). This prevents an excessively hot room by turning on the air conditioner to reduce the indoor room temperature down to 80°F.

With the **Freeze Sentinel** feature "turned on", the unit automatically provides heating (without user interface). This prevents potential plumbing damage by detecting very cold indoor room conditions and runs the heating system to raise the room temperature to 46°F (via heat pump and/or resistance heat operation).

**Heat Sentinel
OFF**

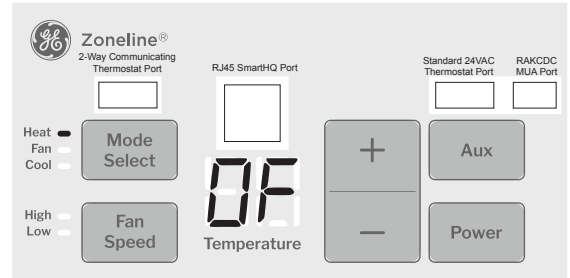

**Heat Sentinel
ON**

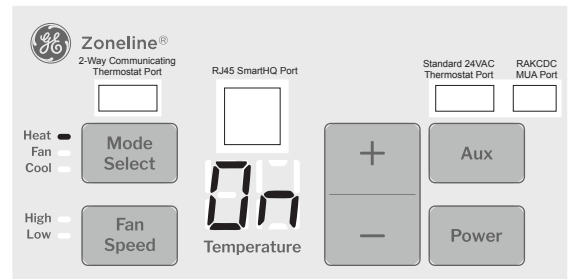

**Freeze Sentinel
OFF**

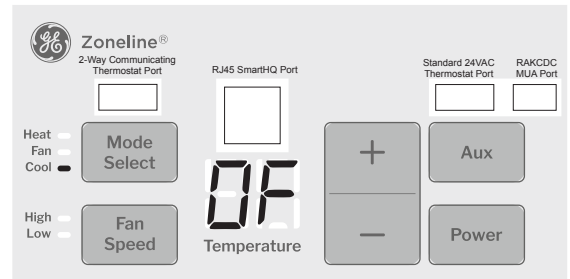

**Freeze Sentinel
ON**

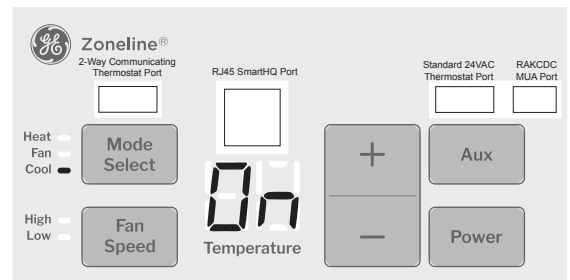

AUX A4 Constant ON Fan

This feature tells the unit to run the indoor fan continuously.

The **default** setting for **Aux A4** is **OFF**



Auxiliary Controls

AUX A5 Temperature Limiting

Temperature limiting is a feature that reduces energy costs by limiting the lowest temperature that can be obtained in cooling and the highest temperature that can be obtained in heating.

The **default** setting for **A5 AUX:**

- **Heat:** 60°F to 78°F (15°C to 25°C)
- **Cool:** 66°F to 85°F (19°C to 29°C)

Temperature Limiting Heat

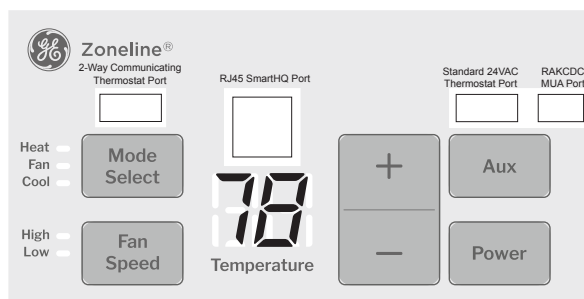

Temperature Limiting Cool

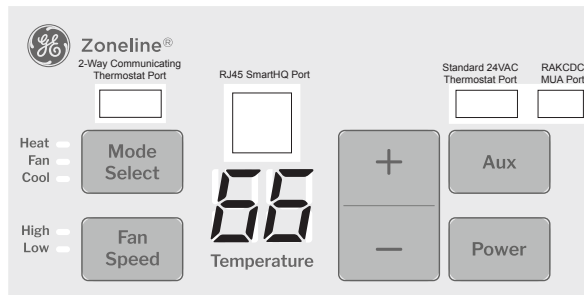

AUX A6 Use Wall Thermostat

Setting this mode to ON will allow the unit to be controlled from a Class 2 Remote Control Wall Thermostat.

The **default** setting for **Aux A6** is **On**

NOTES:

1. When Class 2 mode is "On", the display will show "EE" during normal operation when any key is pressed.
2. When **2-Way thermostat** is connected, unit will automatically **set Aux A6 to "OF" to allow 2-way thermostat control.**



Class 2 OFF
(Local/2-Way
Control)



Class 2 ON
(Standard 24V Remote
Thermostat Control)

AUX A7 Fan Boost (See Static Pressure Tables – page 9)

This setting is used to increase airflow from the unit to ensure proper circulation.

The **default** setting for **Aux A7** is **OFF**



Fan Boost
OFF



Fan Boost
ON

AUX A8 Heat Mode Select (AVV models only)

This setting is used to select the primary mode(s) of heating.

The **default** setting for **Aux A8** is Hybrid "HY"

EH: Electric heat only (Unit provides only E-heat)

Hd: High Demand (AVV models will use an increased compressor speed)

HY: Hybrid - Unit can provide heat through all available modes

Bo: Boost HP (Will use normal Heat Pump and 1KW of electric heat instead of full electric). See Aux A9 to override.

HP: Heat Pump Only (exceptions if unit is faulted or if temperatures are outside of heat pump operation). See Aux A9 to override.



E Heat
Only



High
Demand



Hybrid



Boost
HP



HP Only

Auxiliary Controls

AUX A9 Heat Override (AVV models only)

This setting is used to further define how certain heating modes in **AUX A8** operate.

Aux A9 will only be visible only if Boost Heat Pump "Bo" or Heat Pump Only "HP" is selected in **Aux A8**.

The **default** setting for **Aux A9** is **OFF**

ON enables strict heat operation control as defined in Aux A8

OFF enables the unit to override **Aux A8** and allows the unit to switch to electric heat if heat pump fails to operate or the temperature is outside of the heat pump operation limits.

NOTE: Turning Heat Override on may not provide enough heat.



Heat Override
OFF



Heat Override
ON

AUX b1 Makeup Air Module Fan Speed

(Makeup Air models only)

The make-up air ventilation system is designed to provide continuous outdoor air through the vent door and into the room. In addition to providing fresh air, the unit will work to dehumidify the room when the room is above 50% relative humidity.

The **default** setting for **Aux b1** is **40 CFM**

NOTE: Turning off the fan also closes the Makeup Air duct door.

MAKEUP AIR FAN SPEED

| No Filter (CFM) | RAA13V (CFM) |
|-----------------|--------------|
| 30 | 25 |
| 40 | 30 |
| 50 | 40 |
| 60 | 50 |
| 70 | 60 |
| | 70 |



40 CFM



MUA Off

AUX b2 Makeup Air Filter

This setting tells the unit if you have a MERV 13 filter installed in the Makeup Air system.

The **default** setting for **Aux b2** is **No Filter**

Options for this feature:

- "no" = no makeup air filter installed
- "13" = MERV 13 filter installed



No Filter



MERV 13 Filter

Auxiliary Controls

AUX b3 Makeup Air Module Occupancy

This feature controls the delivery of makeup air based on room occupancy status.

The **default** setting for **Aux b3** is **OFF**

Options for this feature:

- **On** = Makeup air is controlled via 2-way thermostat occupancy sensor or 24V auxiliary input w/ **Aux C1** configured to Occupancy Control "**Oc**"
- **OF** = Makeup Air runs continuously



MUA runs continuous



MUA controlled by occupancy sensor

AUX b4 Dehumidification Controls

This setting provides various approaches to dehumidifying a room (once the temperature is controlled).

The **default** setting for **non**-Makeup Air units, **Aux b4** is **OFF**

The **default** (and minimum) setting for **Makeup Air** units, **Aux b4** is **Standard**

Options for this feature:

- **OFF "OF"**: No additional dehumidification beyond the normal cooling operation.
- **LOW "Lo"**: Target 50% RH
- **Standard "Sd"**: Same as low, but engages 1KW of heat when humidity is above 70%
- **High "HI"**: Same as low, engages 1KW of heat when humidity is above 60%

AUX C1 Auxiliary Input Options

Using an auxiliary 24V input, we allow integration with external devices such as door switches, occupancy sensors, or control from a remote location. Operation of the feature requires that a **normally open** switch at a remote location be wired to the two Auxiliary Input terminals on the control panel of the Zoneline using the RAKCDC Accessory.

Central Desk Control "Cd":

- If the contact is closed, the unit ignores input from external thermostats or user input. Sentinel modes still operate.
- If the contacts are open, the unit will run normally.

Occupancy Control "Oc":

- If the contact is closed and a 2-way thermostat is not connected, the unit will go into an unoccupied state. Therefore, Makeup Air Operation will be disabled.
- If the contact is open, the unit will go into an occupied state and makeup air will resume.



Central Desk Control



Occupancy Mode

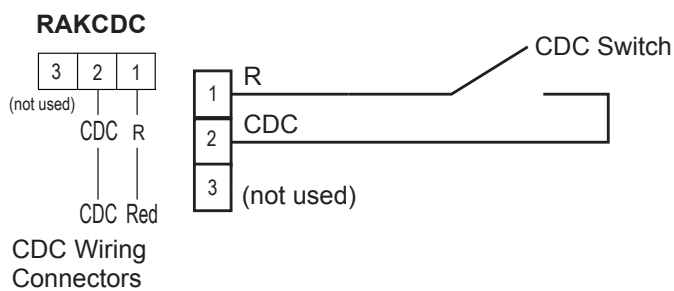

Accessories

Essential Accessories

Zonline Vertical Air Conditioners require a set of essential accessories for proper operation. Once you have selected the size of unit needed, next you'll need to consider the following:

Power Connections- All Zonline Vertical units must be direct connected

POWER CONNECTION REQUIREMENTS (RESISTANCE HEAT)

| 230-208 VOLT | | | |
|------------------------------------|-----------------------------------|-----------------------------------|-----------------------------------|
| POWER CONNECTION KIT | RAK315D | RAK320D | RAK330D |
| Heater BTUh | 8,360/6,838 | 11,770/9,629 | 17,060/13,952 |
| Total Watts | 2,568/2,122 | 3,568/2,940 | 5,118/4,207 |
| Heater Watts | 2,450/2,004 | 3,450/2,822 | 5,000/4,089 |
| Total Heating Amps | 10.7/9.6 | 15/13.6 | 21.7/19.7 |
| MCA | 15 | 20 | 30 |
| Recommend Protective Device (MOCP) | 15 amp time delay fuse or breaker | 20 amp time delay fuse or breaker | 30 amp time delay fuse or breaker |

POWER CONNECTION REQUIREMENTS (RESISTANCE HEAT)

| 265 VOLT | | | |
|------------------------------------|-----------------------------------|-----------------------------------|-----------------------------------|
| POWER CONNECTION KIT | RAK515D | RAK520D | RAK530D |
| Heater BTUH | 8,360 | 11,770 | 17,060 |
| Total Watts | 2,568 | 3,568 | 5,118 |
| Heater Watts | 2,450 | 3,450 | 5,000 |
| Total Heating Amps | 9.2 | 13 | 18.9 |
| MCA | 15 | 20 | 30 |
| Recommend Protective Device (MOCP) | 15 amp time delay fuse or breaker | 20 amp time delay fuse or breaker | 30 amp time delay fuse or breaker |



Telescoping Wall Plenum and Exterior Grille (for Makeup Air Models)

RAVWPT15B

Plenum is easily installed from the interior without the need for exterior building access. Caulking is required. It conveniently expands from 8" to 15" for a custom fit.

Wall cut out 24" W x 40" H

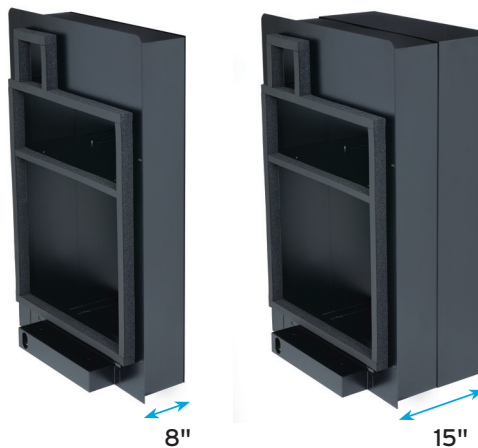

Architectural Louver RAVAL4
Aluminum Outdoor Grille



RAVRG2
Return Air Grille
Cut out:
20-3/8" W x 20-3/8" H



Access Panel with Return Air Grille RAVRG4
Cut out:
28-1/8" W x 55-7/8" H

Drain Platform



RAVDPLAT
Drain Platform

Accessories

Wall Plenum and Exterior Grille (for non-Makeup Air Models)



Wall Plenum
RAVWPT9, RAVWPT15



Exterior Grille
RAVAL3



RAK190V
2-Way Communications



RAK180W1
Energy Management



RAK160W2
2 Fan Speeds

8-Pin

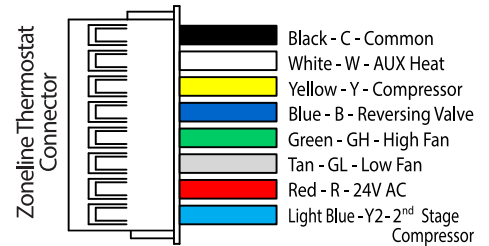

RAK150VF2
2 Comp & Fan Speeds



RAK149F2A
2 Fan Speeds



RAK149P2A
Programmable

4-Pin

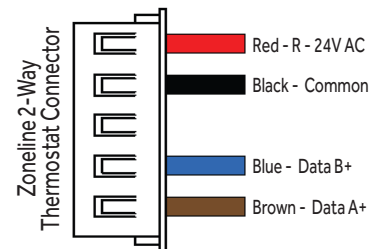

| Zoneline Series | Thermostat Model | Type | Function | Low-Voltage conductors |
|-------------------------|------------------|--|-------------------------------------|------------------------|
| AVV (Variable Speed) | RAK190V | 2 - Way Communication Makeup Air, Occupancy | Variable Speed Control | 4 |
| | RAK150VF2 | Two Compressor and Fan Speeds | Two Stage Cool/Heat | 8 |
| AVE (Fixed Speed) | RAK190V | 1 - Way Communication | Single Stage Cooling and Heating | 4 |
| | RAK180W1 | Energy Management - Wireless MUA, Occupancy | | 2-wire/wireless |
| | RAK160W2 | Wireless | | 2-wire/wireless |
| | RAK150VF2 | Two Compressor and Fan Speeds | | 6 |
| | RAK149P2A | Programable - One fan speed | | 5 |
| | RAK149F2A | Two Fan Speeds | | 6 |

Accessories

Complete Accessory List (Must be ordered separately)

| KIT NUMBER | DESCRIPTION |
|--------------------|--|
| RAK149F2A | Non-programmable - 2 fan speed thermostat - fixed speed models only |
| RAK149P2A | Programmable thermostat - fixed speed models only |
| RAK150VF2 | Two fan speed thermostat for two stage compressor (all models) |
| RAK160W2 | Wireless thermostat - fixed speed models only |
| RAK180W1 | Wireless energy management thermostat, MUA, occupancy - fixed speed models only |
| RAK190V | Two way communicating, occupancy, MUA, energy management thermostat (all models) |
| RAVAL3 | Exterior grille - for non makeup air models |
| RAVAL4 | Exterior grille - for makeup air models |
| RAVTRANS1CO | Transition plenum (select First Company VTACs to a V10 / V11 / V12 Series) |
| RAVTRANS2 | Transition plenum (AZ75 / AZ85 to a V10 / V11 / V12 Series) |
| RAVTRANS3 | Transition plenum - for existing AZ90/91 plenums to new AV models, 8" or more plenum depth) |
| RAVTRANS4 | Transition plenum - for existing AZ90/91 plenums to new AV models, 8" or less plenum depth) |
| RAVRG2B | Return air grille for flush door |
| RAVRG4 | Access panel with return air |
| RAVWPT9 | Wall plenum - for exterior walls up to 8" - non makeup air models |
| RAVWPT15 | Wall plenum - for exterior walls 8" - 15" thick - non makeup air models |
| RAVWPT15B | Wall plenum - for exterior walls 8" - 15" thick - for makeup air models |
| RAVWPT15C | Wall Plenum - for exterior walls 8" - 15" thick - for applications with Energy Recovery Ventilator (ERV) |
| RAK315D | 230-208 volt direct connect power supply kit, 2.45/2 kW heat, 15 amp (Not for use w/2-ton unit) |
| RAK320D | 230-208 volt direct connect power supply kit, 3.45/2.82 kW heat, 20 amp |
| RAK330D | 230-208 volt direct connect power supply kit, 5.0/4.08 kW heat, 30 amp |
| RAK515D | 265-volt universal direct connect power supply kit, 2.45 kW heat, 15 amp |
| RAK520D | 265-volt universal direct connect power supply kit, 3.45 kW heat, 20 amp |
| RAK530D | 265-volt universal direct connect power supply kit, 5.0 kW heat, 30 amp |
| RAVDPLAT | Insta-Platform™ |
| SHCM10PK | SmartHQ™ connect module - (10 pack) |
| RAA13V | MERV 13 makeup air filter - for makeup air models only |

Suggested Specifications

Vertical Zonline Heat Pump

The following are suggested specifications for the Vertical Series single packaged vertical units:

The contractor shall furnish single packaged vertical units of the sizes and capacities shown on the schedule or in the specifications. The units shall be located as shown on the drawings and each shall consist of a chassis, appropriately sized wall plenum, outdoor grille, remote wall thermostat, drain platform, and closet access panel or door.

Units shall be listed by UL and shall be GE Appliances Vertical Zonline models or equal. Unit dimensions shall not exceed 23-5/8"W x 28-3/8"L x 31 7/8" H.

Chassis

The Zonline Vertical units shall be the standard product of the manufacturer and shall be shipped in protective cartons to prevent damage. Cartons shall be appropriately marked with factory wording sufficient to warn handlers against dropping, improper stacking, upending or rolling.

The chassis shall be slide-in type, ready to operate after installation.

The chassis shall be protected against the harmful effects of airborne chemicals and saltwater corrosion.

The chassis shall have a hermetically sealed refrigerant system with an external vibration isolated rotary compressor. Indoor coils shall have copper tubing with aluminum fins. Outdoor coils shall have copper tubing with aluminum fins treated to resist the effects of airborne chemicals and salt-water corrosion. All refrigerant coil fins will have the necessary enhancements to achieve SEER2/EER2 and HSPF2/COP2 ratings of the unit.

Airflow system shall consist of one permanently lubricated fan motor for the outdoor side and a separate permanently lubricated variable motor for the indoor blower.

Outdoor fan shall be a multi-blade axial-flow design made of non-corrosive material. Indoor fan shall be blower type to optimize airflow and minimize air noise. All motors on the exterior side of the weather barrier shall be painted and enclosed to reduce the effects of moisture and corrosion.

Units will have a positive cooling condensate disposal system. The disposal system shall have a slinger ring on the outdoor fan to dispose of condensate water and to assist in cooling the outdoor coil.

Unit indoor and outdoor airflows must match the capacity of the coils for efficient heat transfer and meet latent and sensible heat requirements. Water blow-off shall not occur on the indoor coil.

Unit shall have a sensor to prevent indoor coil freeze up.

Heat Pumps

Heat pump unit shall automatically switch from heat pump operation to electric resistance heat when it is unable to provide sufficient heat to maintain room temperature or when the outdoor temperature is 0° F or less (25° F for fixed speed units).

In the event of a compressor failure during heat pump operation, the unit shall automatically switch to electric resistance heat to maintain selected room temperature regardless of outdoor temperatures.

Unit shall have an indoor coil temperature sensor to protect the compressor when the outdoor temperatures are too high for heat pump operation.

Heat pump models shall be equipped with a temperature activated valve to allow condensate water generated during defrost cycles to drain into the specified drain system.

Wall Plenum

Wall plenums shall be constructed of heavy gauge, zinc coated, phosphated steel with a baked-on enamel finish.

Plenums shall be installed through the exterior wall where shown on the plans and shall be of correct depth to allow sealing to exterior and interior walls.

Exterior Grilles

Each unit shall be equipped with a standard exterior grille that has been designed to allow operation in high ambient conditions.

Special exterior grilles or custom louver sections supplied by others will conform to minimum free area requirements and shall be submitted to independent labs, if requested, for feasibility and air flow characteristics.

Electrical

Units shall be designed to operate on 230/208 or 265-volts, 60 Hz, single-phase power.

Units shall have means of electrical connection listed by Underwriters Laboratories and compatible with the units' required voltage and ampacity in conformance with National Electrical Code (NEC) and all local codes.

Features

Unit must be compatible with 2-wire Central Desk Control systems.

Units must be compatible with Electronic Class-2 remote wall thermostats.

Unit shall be equipped with Freeze Sentinel to automatically activate the electric heaters (at 41°F) and appropriate fan motors to warm and circulate indoor air (to 46°F) to prevent damage due to freezing temperatures. Freeze Sentinel shall operate when unit is connected to a powered electrical circuit.

Unit shall be equipped with Heat Sentinel to automatically provide cooling at 85° F to prevent an excessively hot room. Once the room temperature reaches 80° F, the air conditioner will turn off. When activated, Heat Sentinel shall operate when unit is connected to a power electrical circuit.

Specifications

Vertical Zoneline Heat Pumps

Additional Specifications Service

Submit complete information with bid covering service availability, to whom service on units will be assigned, complete address and phone number, including phone number of emergency service personnel.

Startup, Adjust, Demonstrate

Contractor shall be responsible for the initial starting of units, adjustments thereto, cleaning, etc., to place the units in required operating condition. Contractor shall demonstrate to the owner, or his representative, the operation of units for both summer and winter functions.

2025 Vertical Nomenclature

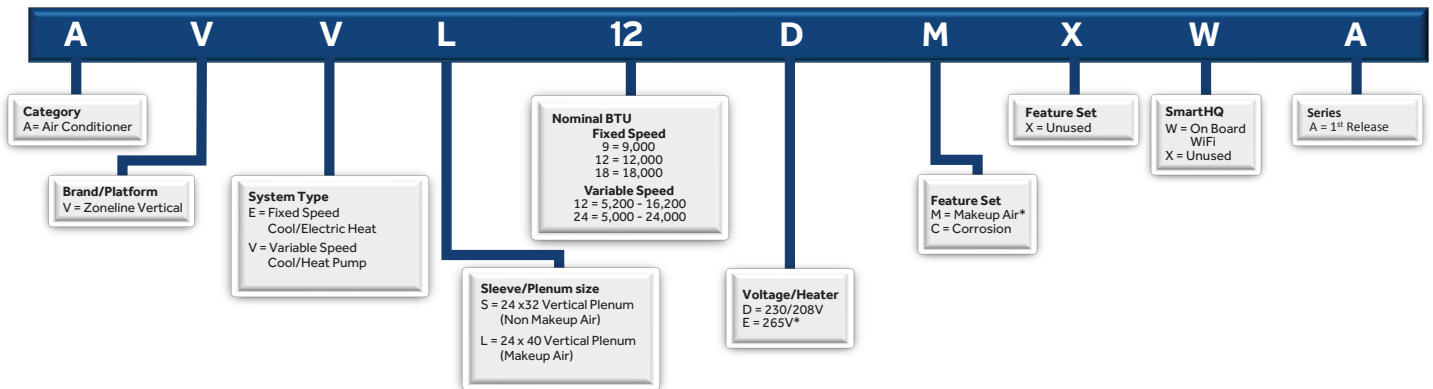

* Not available on fixed speed product

The Vertical Zoneline chassis is identified by a model number defining the type of unit, cooling capacity, electrical information and optional features included on the unit. When specifying or ordering the Zoneline chassis, use of this nomenclature will ensure receiving the correct unit.

Specifications

IMPORTANT NOTICE

Equipment used as a primary source of heating and cooling is an integral part of the building in which it is installed. Proper application is essential for satisfactory performance over a wide range of operating conditions. It is strongly recommended that a professional engineer determines proper application.

When replacing an existing unit, the new units' specifications and performance may differ from those of the existing unit. For that reason, we again strongly recommend that a professional engineer determine proper application.

SPECIFICATIONS-Variable Speed

| 230-208 Volt | 2 - Ton | | 1 - Ton | | 265 Volt | |
|--|--|---------------------|--|-----------------|--|---------------------|
| FEATURES | AVVL24DMXWA | AVVS24DCXWA | AVVL12DMXWA | AVVS12DCXWA | AVVL12EMXWA | AVVS12ECXWA |
| Rated Cooling BTU | 22,400 | 22,400 | 12,500 | 12,500 | 12,500 | 12,500 |
| Cooling BTU Range (95F outdoor) | 5,000-24,200 | 5,000-24,200 | 5,200-16,200 | 5,200-16,200 | 5,200-16,200 | 5,200-16,200 |
| Max Cooling BTU (115F) | 20,200 | 20,200 | 11,200 | 11,200 | 11,200 | 11,200 |
| Max Cooling BTU (75F) | 27,800 | 27,800 | 20,000 | 20,000 | 20,000 | 20,000 |
| EER2 (95F) | 8.9 | 8.9 | 12.0 | 12.0 | 12.0 | 12.0 |
| SEER2 | 16.0 | 16.0 | 17.0 | 17.0 | 17.0 | 17.0 |
| Cooling Watts | 2,615 | 2,615 | 1,050 | 1,050 | 1,040 | 1,040 |
| Cooling Amps | 11.4 | 11.4 | 4.9 | 4.9 | 4.2 | 4.2 |
| Sensible Heat Ratio(SHR) Nominal Cool, High Fan | 70% | 70% | 77% | 77% | 77% | 77% |
| Dehumidification (Pints Per Hour) Nominal Cooling, High Fan | 6.6 | 6.6 | 2.8 | 2.8 | 2.8 | 2.8 |
| Makeup Air CFM | 30-70 (no filter) 25-70 (with MERV13 Filter Kit) | N/A | 30-70 (no filter) 25-70 (with MERV13 Filter Kit) | N/A | 30-70 (no filter) 25-70 (with MERV13 Filter Kit) | N/A |
| Refrigerant | R454B | R454B | R454B | R454B | R454B | R454B |
| Indoor CFM @ 0.3 ESP (High/Low Fan) Nominal Cooling | 715/650 | 715/650 | 450/400 | 450/400 | 450/400 | 450/400 |
| HEAT PUMP | | | | | | |
| Rated Heat Pump BTU | 21,600 | 21,600 | 11,200 | 11,200 | 11,000 | 11,000 |
| Heating BTU Range (47F) | 5,000-23,000 | 5,000-23,000 | 4,500-13,000 | 4,500-13,000 | 4,500-13,000 | 4,500-13,000 |
| HSPF2 | 7.7 | 7.7 | 8.1 | 8.1 | 8.1 | 8.1 |
| Heating COP2 @47F* | 2.7 | 2.7 | 3.5 | 3.5 | 3.5 | 3.5 |
| Heating BTU@17F | 16,700 | 16,700 | 9,100 | 9,100 | 9,100 | 9,100 |
| Heat Pump COP2 @17F | 2.7 | 2.7 | 2.2 | 2.2 | 2.2 | 2.2 |
| Heating BTU @5F | 13400 | 13400 | 9200 | 9200 | 9200 | 9200 |
| Heating COP2 @5F | 1.75 | 1.75 | 1.85 | 1.85 | 1.85 | 1.85 |
| Heat Pump Watts | 2360 | 2360 | 915 | 915 | 905 | 905 |
| Heat Pump Amps | 10.8 | 10.8 | 4.3 | 4.3 | 3.7 | 3.7 |
| CASE DIMENSIONS | | | | | | |
| Width (in.) | 23-5/8 | 23-5/8 | 23-5/8 | 23-5/8 | 23-5/8 | 23-5/8 |
| Depth (in.) | 28-3/8 | 24-1/8 | 28-3/8 | 28-3/8 | 28-3/8 | 24-1/8 |
| Height (in.) | 36-7/8 | 31-7/8 | 36-7/8 | 36-7/8 | 36-7/8 | 31-7/8 |
| Net weight (lbs.) | 145 | 145 | 145 | 145 | 145 | 145 |
| Approx. ship. weight (lbs.) | 158 | 155 | 158 | 158 | 158 | 155 |
| Closet ID for front install (min.) | 29-5/8"W x 32"D | 29-5/8"W x 27-3/4"D | 29-5/8"W x 32"D | 29-5/8"W x 32"D | 29-5/8"W x 32"D | 29-5/8"W x 27-3/4"D |
| Closet ID for side install using full door (min.)** | 29-5/8"W x 34"D | 29-5/8"W x 29-3/4"D | 29-5/8"W x 34"D | 29-5/8"W x 34"D | 29-5/8"W x 34"D | 29-5/8"W x 29-3/4"D |
| Closet ID for side install using RAVRG4** | 34"W x 40"D | NA | 34"W x 40"D | NA | 34"W x 40"D | NA |

*230V Performance Data Listed

**See installation instructions for side installation details

Specifications – subject to change

Specifications

SPECIFICATIONS-Variable Speed-continued

POWER CONNECTION REQUIREMENTS (RESISTANCE HEAT)

| 230/208 VOLT | 9000 & 12,000 BTU | | | 18,000 & 24,000 BTU * | |
|--------------------------------------|-----------------------------------|-----------------------------------|-----------------------------------|-----------------------------------|-----------------------------------|
| Power Connection Kit | RAK315D | RAK320D | RAK330D | RAK320D | RAK330D |
| Heater BTU | 8,360/6,838 | 11,770/9,629 | 17,060/13,952 | 11,770/9,629 | 17,060/13,952 |
| Total Watts | 2,568/2,122 | 3,568/2,940 | 5,118/4,207 | 3,568/2,940 | 5,118/4,207 |
| Heater Watts | 2,450/2,004 | 3,450/2,822 | 5,000/4,089 | 3,450/2,822 | 5,000/4,089 |
| Total Heating Amps | 10.7/9.6 | 15.0/13.6 | 21.7/19.7 | 15.0/13.6 | 21.7/19.7 |
| MCA | 15 | 20 | 30 | 20 | 30 |
| Recommended Protective Device (MOCP) | 15 Amp Time Delay Fuse Or Breaker | 20 Amp Time Delay Fuse Or Breaker | 30 Amp Time Delay Fuse Or Breaker | 20 Amp Time Delay Fuse Or Breaker | 30 Amp Time Delay Fuse Or Breaker |

* There is no 15 amp breaker option available for the 18K & 24K BTU models due to compliance with UL standard 60335-2-40

POWER CONNECTION REQUIREMENTS

| 265 VOLT | RAK515D | RAK520D | RAK530D |
|--------------------------------------|-----------------------------------|-----------------------------------|-----------------------------------|
| Heater BTU | 8,360 | 11,770 | 17,060 |
| Total Watts | 2,568 | 3,568 | 5,118 |
| Heater Watts | 2,450 | 3,450 | 5,000 |
| Total Heating Amps | 9.2 | 13.0 | 18.9 |
| MCA | 15 | 20 | 30 |
| Recommended Protective Device (MOCP) | 15 Amp Time Delay Fuse Or Breaker | 20 Amp Time Delay Fuse Or Breaker | 30 Amp Time Delay Fuse Or Breaker |

Specifications – subject to change

SPECIFICATIONS-Fixed Speed

| 230-208 Volt | | | |
|-----------------------------------|----------------------------|----------------------------|----------------------------|
| FEATURES | AVES09DCXXA | AVES12DCXXA | AVES18DCXXA |
| Rated Cooling BTU | 8,800/8,900 | 12,400/12,500 | 17,200/17,300 |
| EER2 | 12.1/12.0 | 11.8/11.7 | 10.9/10.9 |
| SEER2 | 14.3/14.0 | 12.8/12.8 | 12.1/12.0 |
| HSPF2 | NA | NA | NA |
| Cooling Watts | 735/750 | 1060/1075 | 1575/1585 |
| Cooling Amps | 3.7/3.5 | 5.6/5.2 | 8.1/7.4 |
| Sensible Heat Ratio(SHR) | 76% | 72% | 74% |
| Dehumidification (Pints Per Hour) | 1.8 | 3 | 4.2* |
| Refrigerant | R454B | R454B | R454B |
| Indoor CFM (Hi/Lo) (0.3 ESP) | 320/290 | 400/360 | 530/490 |
| CASE DIMENSIONS | | | |
| Width (In.) | 23-5/8 | 23-5/8 | 23-5/8 |
| Depth (In.) | 24-1/8 | 24-1/8 | 24-1/8 |
| Height (In.) | 31-7/8 | 31-7/8 | 31-7/8 |
| Net Weight (Lbs.) | 119 | 127 | 141 |
| Approx. Ship. Weight (Lbs.) | 132 | 140 | 154 |
| Clearance For Front Install (Min) | 3" On All Sides | 3" On All Sides | 3" On All Sides |
| Clearance For Side Install (Min) | 5" To Front 3" On Sides | 5" To Front 3" On Sides | 5" To Front 3" On Sides |

*18K Dehum Rate and SHR data acquired using medium fan speed. All other models show low fan speed data.

POWER CONNECTION REQUIREMENTS (RESISTANCE HEAT)

| 230/208 VOLT | 9000 & 12,000 BTU | | | 18,000* | |
|--------------------------------------|-----------------------------------|-----------------------------------|-----------------------------------|-----------------------------------|-----------------------------------|
| Power Connection Kit | RAK315D | RAK320D | RAK330D | RAK320D | RAK330D |
| Heater BTU | 8,360/6,838 | 11,770/9,629 | 17,060/13,952 | 11,770/9,629 | 17,060/13,952 |
| Total Watts | 2,568/2,122 | 3,568/2,940 | 5,118/4,207 | 3,568/2,940 | 5,118/4,207 |
| Heater Watts | 2,450/2,004 | 3,450/2,822 | 5,000/4,089 | 3,450/2,822 | 5,000/4,089 |
| Total Heating Amps | 10.7/9.6 | 15.0/13.6 | 21.7/19.7 | 15.0/13.6 | 21.7/19.7 |
| MCA | 15 | 20 | 30 | 20 | 30 |
| Recommended Protective Device (MOCP) | 15 Amp Time Delay Fuse Or Breaker | 20 Amp Time Delay Fuse Or Breaker | 30 Amp Time Delay Fuse Or Breaker | 20 Amp Time Delay Fuse Or Breaker | 30 Amp Time Delay Fuse Or Breaker |

* There is no 15 amp breaker option available for the 18K & 24K BTU models due to compliance with UL standard 60335-2-40

Specifications – subject to change

Wiring Diagrams

Variable Speed Wiring Diagram

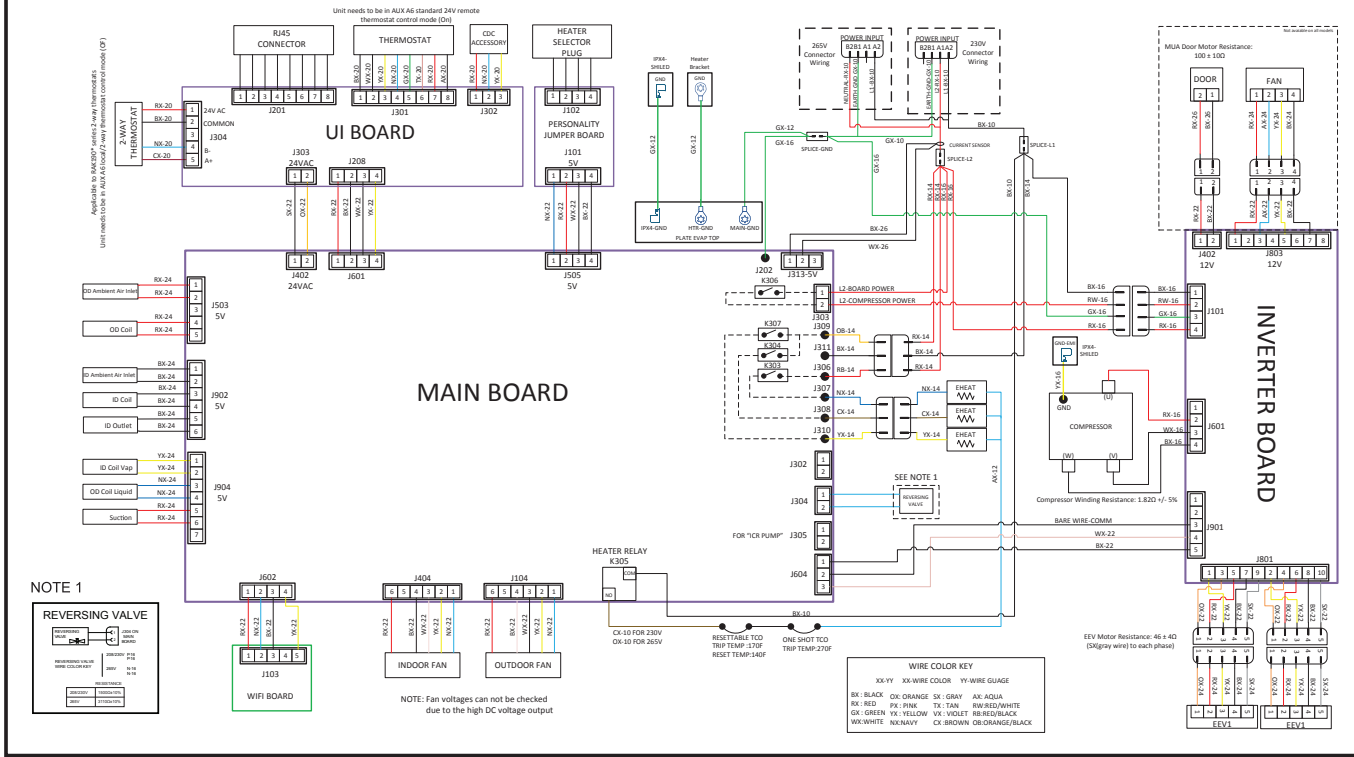

Single Speed Wiring Diagram

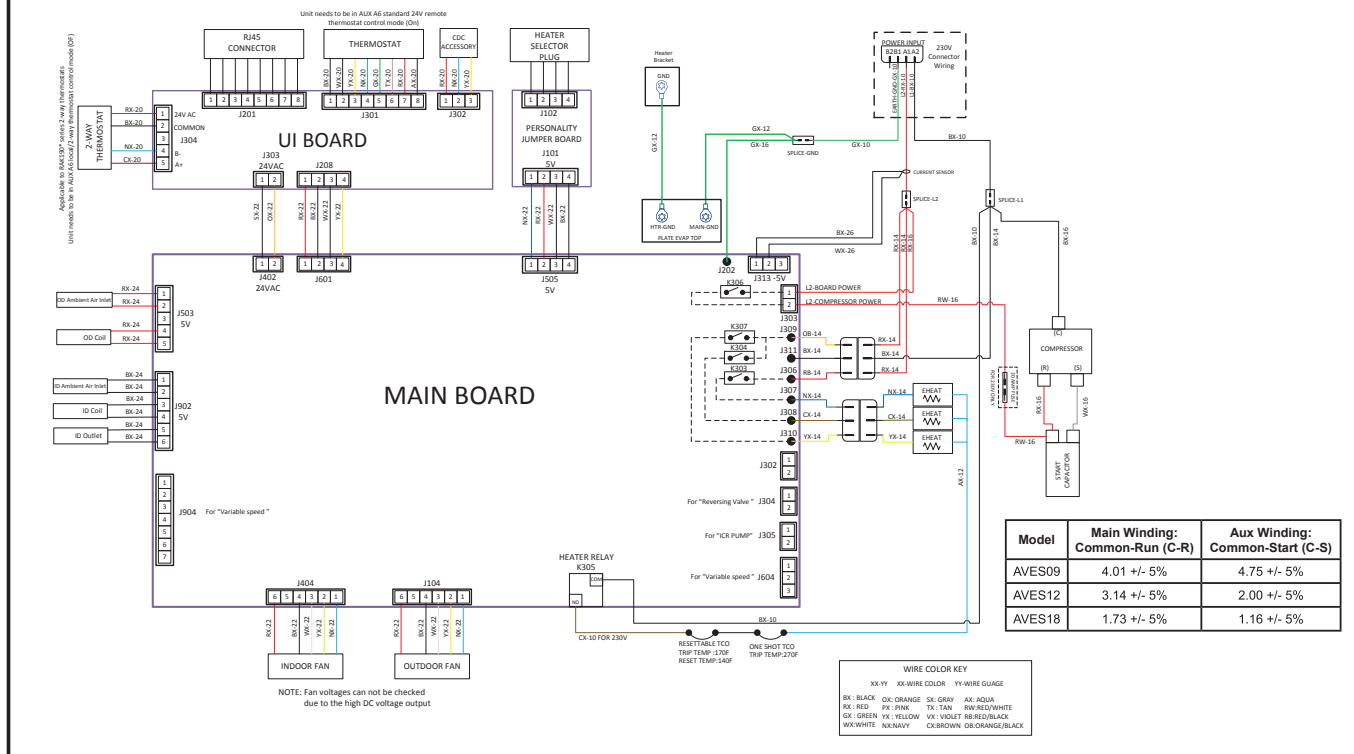

Zonline Vertical Warranty

Proof of original purchase date is needed to obtain service under warranty. For service in the U.S., call 1-844-GE4-PTAC (1-844-434-7822). In Canada, contact your local distributor.

| For the period of | GE Appliances will replace |
|--|--|
| One year From the date of the original purchase | Any part of the air conditioner which fails due to a defect in materials or workmanship. During this limited one-year warranty, GE will provide, free of charge, all labor and related service costs to replace the defective part. |
| Five years From the date of the original purchase | Sealed Refrigerating System—if any part of the Sealed Refrigerating System (the Compressor, Condenser, Evaporator, Reversing Valve, Expansion Device and all connecting tubing) should fail due to a defect in materials or workmanship. During this limited five-year warranty, GE will provide, free of charge, all labor and related service costs to replace the defective part. |
| Second through fifth year From the date of the original purchase | Fan Motors, Switches, Heater, Heater Protectors, Solenoids, Expansion Device Motors, Circuit Boards, Auxiliary Controls, Thermistors, Freeze Sentinel, Frost Controls, ICR Pump, Capacitors, Varistors, Indoor Blower Bearing, Makeup Air Fan, and Makeup Air Damper Door System, if any of these parts should fail due to a defect in materials or workmanship. During this additional four-year limited warranty, GE will provide the replacement part free of charge. The customer will be responsible for any labor and related service costs. |

See written warranty for details

What Is Not Covered

- Service trips to your site to teach you how to use the product.
- Improper installation.
If you have an installation problem, or if the air conditioner is of improper cooling capacity for the intended use, contact your dealer or installer.
You are responsible for providing adequate electrical connecting facilities.
- Replacement of fuses or resetting of circuit breakers.
- In commercial locations, labor necessary to move the unit to a location where it is accessible for service by an individual technician.
- Failure of the product resulting from modifications to the product or due to unreasonable use including failure to provide reasonable and necessary maintenance.
- Failure or damage resulting from corrosion due to installation in an environment containing corrosive chemicals.
- Failure or damage resulting from corrosion due to installation in a coastal environment, except for models treated with special factory-applied anti-corrosion protection as designated in the model number.
- Damage to product caused by improper power supply voltage, accident, fire, floods or acts of God.
- Incidental or consequential damage to personal property caused by possible defects with this air conditioner.

Warrantor: GE Appliances. Louisville, Ky 40225

This warranty is extended to the original purchaser and any succeeding owner for products purchased for use within the USA and Canada. In Alaska, the warranty excludes the cost of shipping or service calls to your site.

Some states do not allow the exclusion or limitation of incidental or consequential damages. This warranty gives you specific legal rights, and you may also have other rights which vary from state to state. To know what your legal rights are in your state, consult your local or state consumer affairs office or your state's Attorney General.

Visit: [zoneline.com](https://www.zoneline.com)

For Literature, REVIT, & CAD files visit:

<https://www.geappliances.com/ge/zoneline/liter>



GE APPLIANCES
a Haier company

AIR & WATER
S O L U T I O N S

GE is a trademark of the General Electric Company.
Manufactured under trademark license.

Copyright © 2025 GE Appliances. All rights reserved.

Zoneline, UltimateV12 and other names are trademarks
or registered trademarks of GE Appliances in the United States
and other countries.

ature.htm

Appliance Park
Louisville, KY 40225
geappliances.com
zonline.com | 888.231.2548
Pub No. 20-S0018-25
OTGEA9653562999