



CWC5ADA



34" x 21.5" x 24" (H x W x D)

Fully assembled casework trash cabinet in ADA compliant height and black finish with garbage and recycling bins included

Highlights:

Ships fully assembled

Made in the USA

34" counter height to meet ADA guidelines for accessibility

Product Features:

Casework trash receptacle cabinet	21.5" wide cabinet with swing door
Ships fully assembled	No assembly required for fast installation in your space
ADA Compliant height	34" high to meet ADA guidelines for accessibility
Made in the USA	Engineered wood with laminate finish manufactured and assembled in the United States
Trash bins included	Two bins packaged inside for easier separation of recyclables and rubbish
Two counter holes	Designed to line up over the trash bins for easy use
Lockdowel™ construction	Innovative fastening system ensures lasting durability
Black finish	Sleek black laminate finish suits any setting
Leveling legs	Four levelers allow easier adjustment to accommodate uneven floors



CWC5ADA Specifications:

Overview	
Nominal Width	22.0" (56 cm)
Nominal Depth	24.0" (61 cm)
Nominal Height	34.0" (86 cm)
Height of Cabinet	34.0" (86 cm)
Width	21.5" (55 cm)
Depth	24.0" (61 cm)
Cabinet	Black
Weight	100.0 lbs. (45 kg)
Parts & Labor Warranty	90 Days
UPC	761101088501

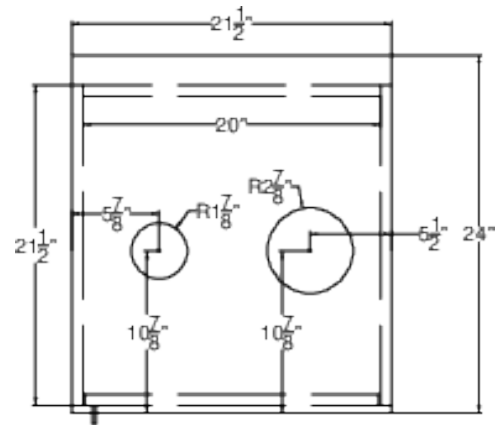

Plan

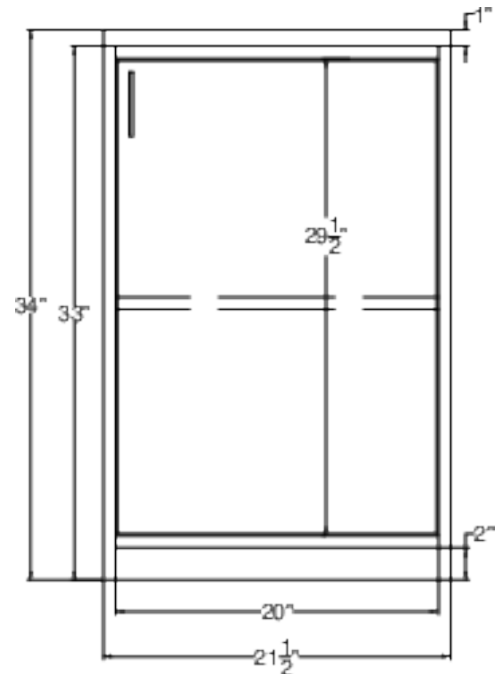

Elev