

PRODUCT DIMENSIONS

SIDE VIEW

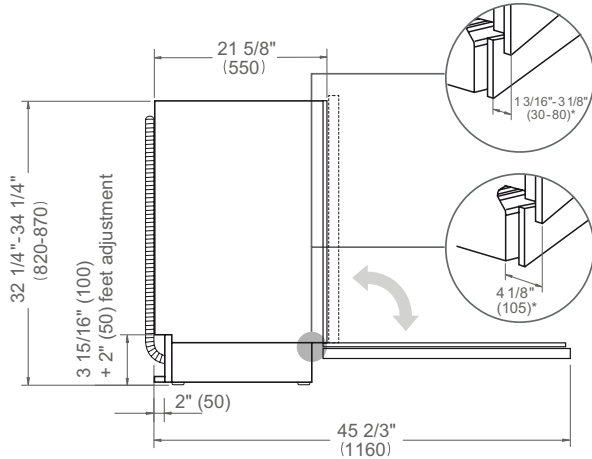

FRONT VIEW

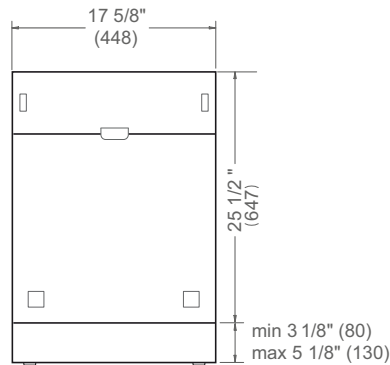

TOP VIEW

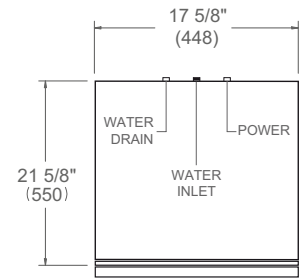

Drain hose and toe kick are provided with the unit

* including a 3/4" (20) thick custom panel

CUTOUT DIMENSIONS

SIDE VIEW

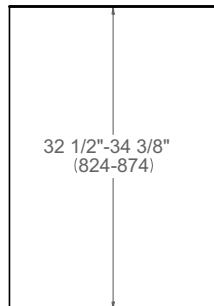

FRONT VIEW

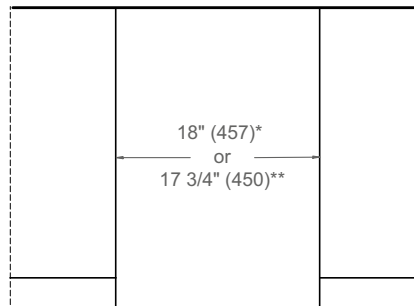

* with vertical side trims installed
** without vertical side trims

TOP VIEW

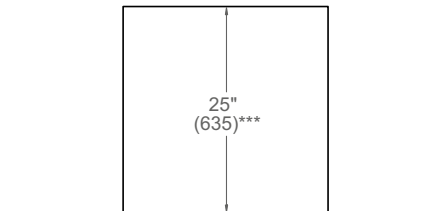

***Cabinet depth shown includes kitchen cabinet front panel. For a flush installation, a minimum inset depth of 22 1/2" (570) is required with a custom door panel thickness of 3/4" (20).

ELECTRICAL & WATER CONNECTION

E A properly-grounded, horizontally-mounted electrical receptacle should be installed according to this drawing.

W To connect the water mains to the water inlet valve thread, use a 3/8" water inlet hose and 3/4" metal adapter with a length of 60" (1524) (not supplied).

TOP VIEW

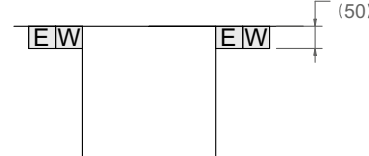

FRONT VIEW

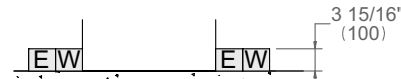

Connections placement must be located on either side of the cutout.

CUSTOM PANEL

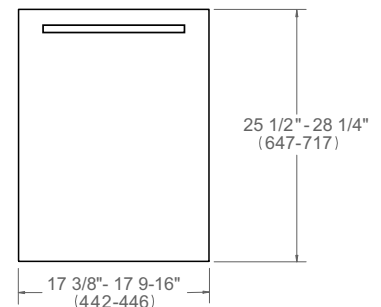

Door tension can be adjusted to accommodate custom panel weights from 7 lb (3 kg) to 13 lb (6 kg). Suggested panel thickness is 3/4" (20).

Dimensions in parentheses are millimeters unless otherwise specified.

INSTALLATION REQUIREMENTS

Follow local codes & ordinances for drain requirements. Install a waste line with an air gap (not supplied) or, alternatively, at least 30" (762) high drain loop to prevent backflow. Drain hose is 74" (1880) long. Drain hose must be connected at minimum 20" (508) from the floor. Ensure that the designated cabinet space is delimited by side panels or a 3" (76) return on each side, with a minimum thickness of 5/8" (16) for proper support.