

## Ellipse Dual Mount Sink - ESOX25229-1 | 114.0087.736

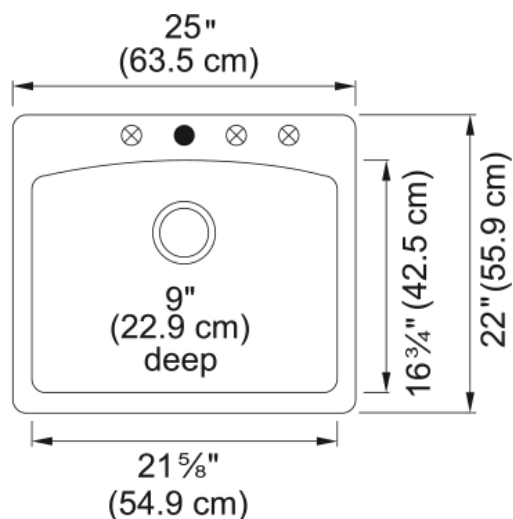

25-in. x 22-in. Onyx Fraganite Dual Mount Single Bowl Kitchen Sink. Ellipse Fraganite sinks are durable and resistant to scratches, stains and heat.

### Aspect

Sink type	Sink
Type of material	Granite
Number of bowls	1
Color	Onyx
Surface finish	None

### Product Dimensions

Length (right to left)	25
Width (front to back)	22
Large bowl size: right to left	21.85
Large bowl size: front to back	16.89
Large bowl: depth	9.016

### Installation

Minimum cabinet size	27"
----------------------	-----

### Product specifications

Installation type	Topmount / drop in
Drain hole	3 1/2"
Position of drainer	No drainer

### Product identification

Product brand	FRANKE
Product family	None
Collection	Ellipse
Certified by	CE

### Features

Drainers number	No drainer
Product reversibility	No
Faucet ledge	Yes
Strainer assembly included	No

Strainer Assembly	No waste kit
Overflow	No
Number of faucet holes	4 - pre-scored
Soap dispenser hole	No