

GAS BUILT-IN RANGE

EW30GS65GS

Featuring Wave-Touch® Electronic Controls



PRODUCT DIMENSIONS

Height	35-5/8" – 36-5/8"
Width	30"
Depth (to Center of Arc) (with 90° Door Open)	28-5/16" 45-1/2"

MORE EASY-TO-USE FEATURES

DEEP-WELL DESIGN

Keeps spills contained for easy cleanup and lowers the cooking surface to counter-top level, which makes moving oversized pots and pans onto an off of the cooking surface much easier.

WAVE-TOUCH® CONTROLS

One simple touch and the control panel activates, showing your cooking options. After you make your choice, all but the options selected will fade away, returning to an elegant display.

6 COOKING MODES

Bake, Broil, Convection Bake, Convection Roast, Keep Warm and Slow Cook.

PRECISE BAKING OPTIONS

Includes Perfect Turkey®, Defrost, Dehydrate, Bread-Proof, "My Favorites," Multi-Stage Cooking, Temperature Probe, Rapid Preheat, Delay Bake and Convection Convert.

PLATINUM STAR® LIMITED WARRANTY

Our exclusive limited warranty that includes a 3-year coverage on parts and one year on labor without charge.¹

CONTINUOUS GAS GRATES

Designed for cooking multiple dishes at varying temperatures on a single cooktop. These grates allow easy movement of even the heaviest pots and pans from burner to burner — without lifting.

ADA COMPLIANT

When properly installed, this model is A.D.A.-qualified based on the United States Access Board's A.D.A./A.B.A. Accessibility Guidelines and the Department of Justice's 2010 A.D.A. Standards for Accessible Design.

Available in:



Stainless
(S)

SIGNATURE FEATURES



PERFECT TURKEY® BUTTON

Ensures moist, delicious poultry. Imagine stress-free holiday cooking.



LUXURY-GLIDE® OVEN RACKS

With a ball bearing system, oven racks are so smooth they extend effortlessly.



MIN-2-MAX BURNER®

Designed with a dual-flame sealed burner, this cooktop offers the widest range of BTU performance in the industry for the utmost versatility — from a roaring 18,000-BTU boil to a gentle 450-BTU simmer.



PERFECT CONVECT3®

Our convection technology features a third convection element for consistently even results, up to 30% faster cooking times and even more baking options.

BURNER	BTU
Min-2-Max® Dual-Flame Burner	450-18,000
Sealed Power Burner	14,000
Sealed Precision Burner	9,500
Sealed Precision Burner	850-5,000

¹Eligibility based on product registration with Electrolux North America within 60 days of purchase. Products must have been purchased on or after July 1, 2013. Coverage includes material parts for 3 years and labor for 1 year.

GAS BUILT-IN RANGE

EW30GS65GS



30" GAS BUILT-IN RANGE

CONTROL PANEL FEATURES

Wave-Touch® Electronic Oven Control	Yes
Professional-Grade Burner Controls	Yes
Keypad Entry of Time & Temperature	Yes
Electronic Clock & Timer	Yes
Temperature Display	Yes
Automatic Oven (Delay, Cook & Off)	Yes

COOKTOP FEATURES

Min-2-Max Dual-Flame Sealed Burner® – 18,000 - 450 BTU	1
Sealed Power Burner – 14,000 BTU	1
Sealed Precision Burner – 9,500 BTU	1
Sealed Precision Burner – 5,000 BTU - 850 BTU	1
Linear Flow Burner Valves	Yes
Seamless Cooktop	Yes
Continuous Grates with Deep-Well Top	3
Electronic Pilotless Ignition	Yes

OVEN FEATURES

Capacity	4.2 Cu. Ft.
Hidden Bake Burner	Yes
Bake Burner – 18,000 BTU	Yes
Broil Burner – 11,500 BTU	Yes
Convection Burner – 350 Watts	Yes
Cobalt Blue Interior	Yes
Self-Clean Options with Door Lock	3
Perfect Convection® with Variable 2-Speed Fan	Yes
Cooking Modes – Bake, Broil, Convection Bake, Convection Roast, Keep Warm, Slow Cook	6
Baking Options – Perfect Turkey®, Defrost, Dehydrate, Bread Proof, My Favorites, Multi-Stage Cooking, Temperature Probe, Rapid Preheat, Delay Bake, Convection Convert	10
Luxury-Design® Lighting with Dual 40W Halogen Bulbs	Yes
Luxury-Glide® Racks	2
Conventional Racks	1
Convection Roasting Rack	Yes

ADDITIONAL FEATURES

Luxury-Hold™ Oven Door	Yes
Extra-Large Glass Window	Yes
Warmer Drawer	Yes
Adjustable Leveling Legs	Yes
Sabbath Mode (Star-K® Certified)	Yes
A.D.A. Compliant*	Yes

ACCESSORIES

Porcelain Broiler Pan and Insert	Included
Grill / Griddle – PN# 316534001	Mail-In Card
Wok Ring – PN# 318254307	Optional
Simmer Plate – PN# 318254206	Optional
LP Gas Conversion Kit	Included
2" Rear Filler Kit – PN# 903113-901S	Optional
Side Panel Kit – PN# 903102-901S	Optional
Backguard Kit – PN# 903111-901S	Optional
Side Trim Kit – PN# 903110-901S	Optional

SPECIFICATIONS

Color –	
Stainless Steel	S
Gas / Power Supply Connection Location	Right / Left Bottom Rear
Voltage Rating	120V / 60Hz / 15A
Connected Load (kW Rating) @ 120 Volts†	1.2
Shipping Weight (Approx.)	270 Lbs.

*When properly installed, this model is A.D.A.-qualified based on the United States Access Board's A.D.A./A.B.A. Accessibility Guidelines and the Department of Justice's 2010 A.D.A. Standards for Accessible Design.

†For use on adequately wired 120V, dedicated circuit having 2-wire service with a separate ground wire. Appliance must be grounded for safe operation.

NOTE: Always consult local and national electric and gas codes. Refer to Product Installation Guide for detailed installation instructions on the web at electroluxappliances.com.

Specifications subject to change.

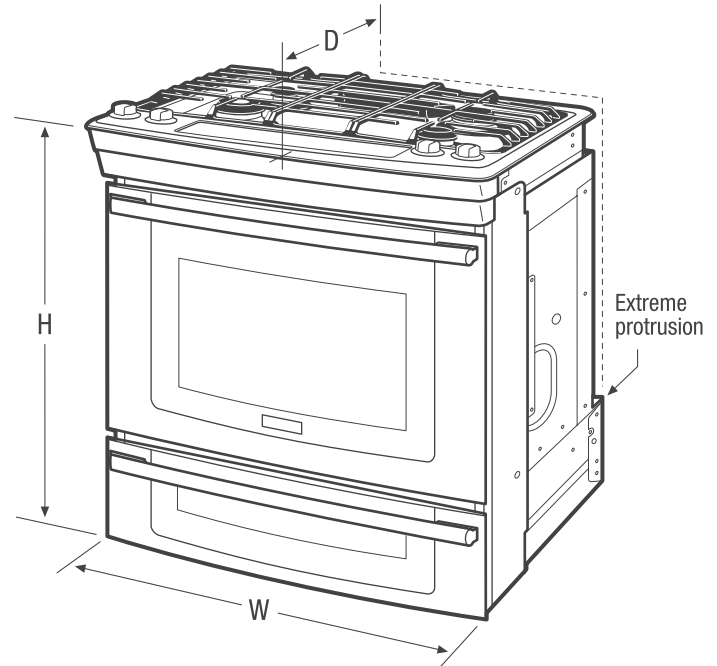

PRODUCT DIMENSIONS

Height (Adjustable)	35-5/8" – 36-5/8"
Width	30"
Depth (to Center of Arc) (with 90° Door Open)	28-5/16" / 45-1/2"

OVEN CAVITY DIMENSIONS

Height	16-1/2"
Width	24-1/8"
Depth	18-1/32"

Electrolux Major Appliances, N.A.

USA • 10200 David Taylor Drive • Charlotte, NC 28262 • 1-877-4electrolux (1-877-435-3287) • electroluxappliances.com
 CANADA • 5855 Terry Fox Way • Mississauga, ON L5V 3E4 • 1-800-265-8352 • electroluxappliances.ca

EW30GS65G 03/15

© 2015 Electrolux Home Products, Inc.



High standards of quality at Electrolux Home Products, Inc. mean we are constantly working to improve our products. We reserve the right to change specifications or discontinue models without notice.