

Version	FDMOV30W5SB / Built-in 30" (80 cm) - Black - 500 CFM
Collection	Design

FEATURES AND PROPERTIES

Materials/Finishes	Scotch brite stainless steel (AISI 304)
Materials/Finishes	Lower part in black tempered glass
Features	Sliding door Automatic switch-on function (fast heating up)
Control	Electronic control
Ducting type	Extracting/Filtering
Chimney	Optional Chimney
Shelf	Optional glass shelf
Installation type	Insert
Lighting	LED
Filters	Metallic grease filter, removable and washable Combined regenerable Carbon.Zeo filter (optional)
Ducting type	
Dimensions	30 in
Minimum Electric hob distance	21 in
Minimum Gas hob distance	21 in
Notes	Availability Carbon.Zeo filter KACL.961 for hoods produced from 02/05/2021. Availability Carbon.Zeo filter KACL.1039 for hoods produced from Sept. 2024 Recommended mounting height from cooking surface to hood bottom: 20".



Photograph is for information purposes only. May not correspond to the selected version

ELECTRICAL CONNECTION AND CONSUMPTION

Maximum consumption	280 W
Voltage/Frequency	110-120V 60Hz

BLOWER PERFORMANCE

Motor	500 CFM
Minimum sound level	0 dB (A)re1pW I.E.C. 60704-2-13
Maximum sound level	0 dB (A)re1pW I.E.C. 60704-2-13

WEIGHTS AND DIMENSIONS

Gross weight	38 lbs
Net weight	36 lbs
Volume	4 ft
Packaging dimensions	L 0 x H 0 x D0 in

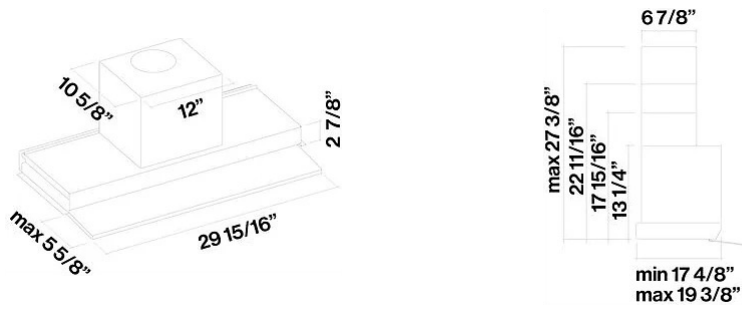

OPTIONAL ACCESSORIES

Code	Description
KACL.815	Protective cleaning cloths for stainless steel (box 10 pcs)
KCVJN.01#3	Kit Chimney Virgola-Move H120 Stainless Steel
KCVJN.00#3	KIT CHIMNEY VIRGOLA-MOVE H=185 + Ext. H=185 Stainless Steel
KACL.798#21F	FDNUVMTR600 - Motor 600 CFM for North America
KACL.1039	Carbon.Zeo Microtech renewable filter
KACL.1059	