



15" W. NUGGET ICE MACHINE

FNIU

PROFESSIONAL FEATURES

- Makes 1/2" L x 3/8" H x 5/8" W ice bits
- Produces up to 65 pounds of nugget ice per day
- Stores up to 27 pounds of nugget ice
- Ice scoop included with dedicated holder
- Factory-installed drain pump included
- Digital controls
- Simple 20 minute clean cycle
- Indicator lights show when drain is activated and if water issues are detected
- Arctic white LED lighting
- Arctic white interior
- Designed for built-in or freestanding applications
- Soft-close articulating door hinge with reversible door
- Accepts 3/4" or 5/8" custom panels or accessory door panel kits
- No water filtration required



FNIU515D
(shown with custom panel)

MODEL NUMBER

- FNIU515D – 15" Nugget Ice Machine with Pump, Solid Panel Ready

ACCESSORIES

- PDPUS115SS – Professional Door Panel, Stainless Steel
- CDPUS115SS – Classic Door Panel, Stainless Steel

DESIGN OPTIONS

- Field reversible soft-close door allows for right or left swing
- Choice of two accessory door panel kits for each unit
 - Professional Door Panel features the iconic Viking handle for true design integrity
 - Classic Door Panel features a slim handle that coordinates with any kitchen design

WARRANTY

- 2-year full covers complete unit
- 90-day full – cosmetic parts such as glass, painted items, and decorative items
- 6-year full – sealed refrigeration system



15" W. NUGGET ICE MACHINE

FNIU

15" W. NUGGET ICE MACHINE	
DESCRIPTION	FNIU515D
Overall Width	14-7/8" (37.8 cm)
Overall Height	33-9/16" to 34-1/16" (85.2 to 86.5 cm)
Overall Depth from Rear	To front of door: To handle: 25" (63.5 cm) With door at 90° angle: 37-3/8" (94.9 cm)
Electrical Requirements	115V/60Hz/15A
Amps: Running	3.0 amps
Maximum Storage Capacity	27 lbs.
Cord Length	6 ft.
Interior Finish	Arctic White
ENERGY STAR	Yes
Refrigerant Type	R600a
Sabbath Mode	Yes
Shipping Dimensions	19" W. x 31" D. x 37" H.
Approximate Shipping Weight	101 lbs. (45.8 kg)

Please do not prepare installation from brochure data only. See installation instructions for important clearance/installation information.

Rough-In Opening Dimensions			Cabinet Dimensions					
A	B	C	D	E	F	G	H	I
15" (38.1 cm)	33-3/4" to 34-1/4" (85.7 to 87 cm)	24" (61 cm)	14-7/8" (37.8 cm)	33-9/16" to 34-1/16" (85.2 to 86.5 cm)	23" (58 cm)	25" (63.5 cm)	37-3/8" (94.9 cm)	17" (43.2 cm)

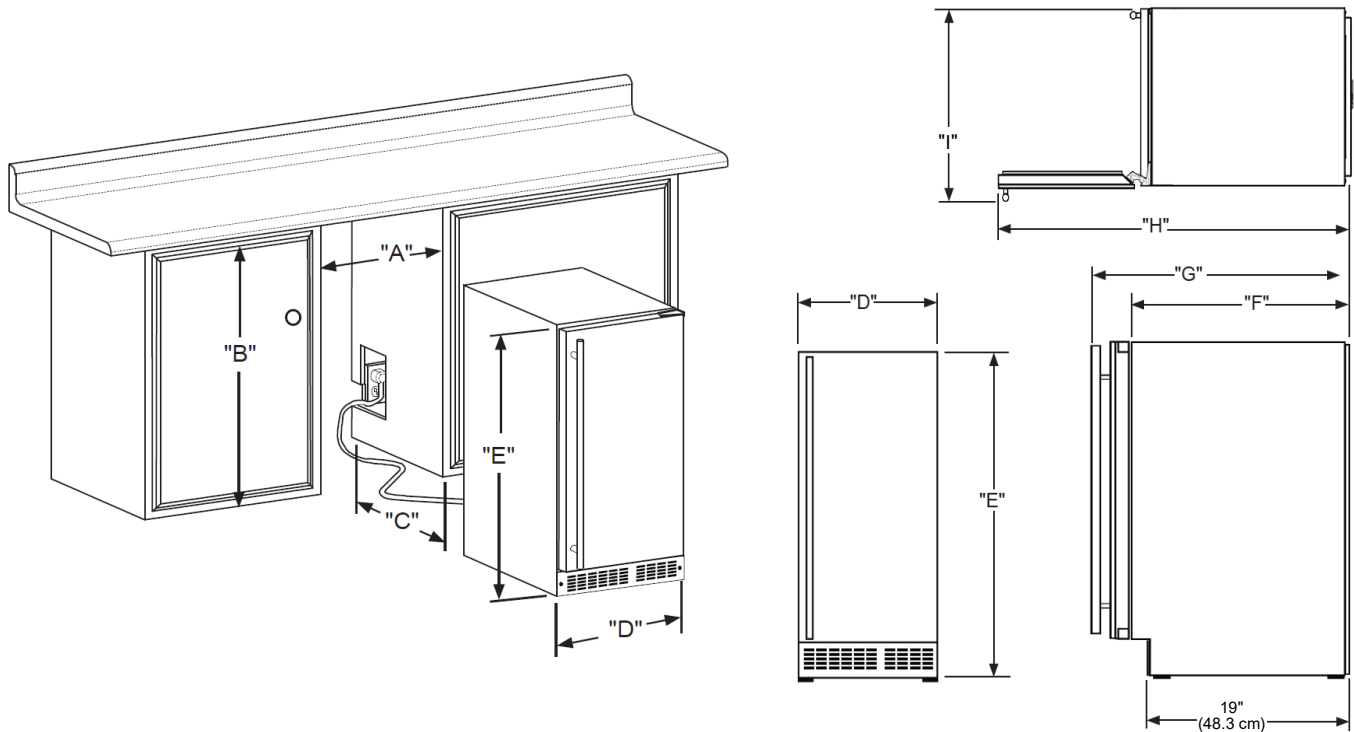

VIKING RANGE, LLC 111 FRONT STREET GREENWOOD, MISSISSIPPI 38930 USA

For detailed product information, model numbers, or to request a quote call 1-888-845-4641 or visit vikingrange.com

© 2026 Viking Range, LLC All rights reserved. Specifications subject to change without notice.