

<b>Version</b>	FNLNA36I5SS / Island 36" (90 cm) - Steel - 500 CFM
<b>Collection</b>	Silence - NRS

**FEATURES AND PROPERTIES**

<b>Materials/Finishes</b>	Scotch brite stainless steel (AISI 304)
<b>Materials/Finishes</b>	Tempered glass with white finish
<b>Technology</b>	NRS technology for a quieter kitchen
<b>Features</b>	Perimeter suction
<b>Control</b>	Touch control
<b>Ducting type</b>	Extracting/Filtering
<b>Installation type</b>	Island
<b>Lighting</b>	Fluorescent ambient light Fluorescent lighting Fluorescent
<b>Filters</b>	Metallic grease filter, removable and washable Combined Carbon.Zeo filter, regenerable
<b>Ducting type</b>	
<b>Dimensions</b>	36 in
<b>Minimum Electric hob distance</b>	21 in
<b>Minimum Gas hob distance</b>	26 in
<b>Notes</b>	Recommended mounting height from cooking surface to hood bottom: 24" - 35";  Availability Carbon.Zeo filter KACL.961 for hoods produced from 11/02/2020  Availability Carbon.Zeo filter KACL.1039 for hoods produced from Sept. 2024



Photograph is for information purposes only. May not correspond to the selected version

**ELECTRICAL CONNECTION AND CONSUMPTION**

<b>Maximum consumption</b>	280 W
<b>Voltage/Frequency</b>	110-120V 60Hz
<b>Connection type</b>	Hood comes standard with Nema 5-15P power cord

**BLOWER PERFORMANCE**

<b>Motor</b>	500 CFM
<b>Minimum sound level</b>	37 dB (A)re1pW I.E.C. 60704-2-13
<b>Maximum sound level</b>	46 dB (A)re1pW I.E.C. 60704-2-13

**WEIGHTS AND DIMENSIONS**

<b>Gross weight</b>	115 lbs
<b>Net weight</b>	100 lbs
<b>Volume</b>	22 ft
<b>Packaging dimensions</b>	L 43 x H 26 x D35 in

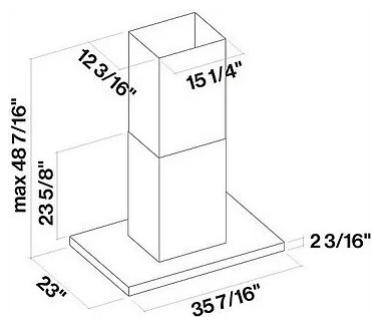

## OPTIONAL ACCESSORIES

<b>Code</b>	<b>Description</b>
KACL.572#I	Extension H1200 Island - Inox
KACL.815	Protective cleaning cloths for stainless steel (box 10 pcs)
KACL.400	Silent / Conveyor NRS
KACL.1039	Carbon.Zeo Microtech renewable filter

## ENGINE SPECIFICATIONS

Motor speed	1	2	3	4
Noise dB(A) re1pW I.E.C. 60704-2-13	37	41	46	54,5
Capacity	220	290	375	610
Maximum pressure (Pa)	390	440	490	510
Motor power (W)	130	150	178	224
Air outlet	150	150	150	150

## CAPACITY / PRESSURE

