

**Version** FPMER24W3SS / Wall 24" (60 cm) - 280 CFM  
**Collection** Potenza

**FEATURES AND PROPERTIES**

**Materials/Finishes** Scotch brite stainless steel  
**Control** Mechanical control  
**Ducting type** Extracting/Filtering  
**Installation type** Wall  
**Lighting** Led 2x1,2 W - 3200 K  
**Filters** Metallic grease filter, removable and washable  
 Charcoal filter (optional)  
**Ducting type**  
**Dimensions** 24 in  
**Minimum Electric hob distance** 21 in  
**Minimum Gas hob distance** 25 in  
**Notes** Recommended mounting height from cooking surface to hood bottom: 24" - 35"



Photograph is for information purposes only. May not correspond to the selected version

**ELECTRICAL CONNECTION AND CONSUMPTION**

**Maximum consumption** 150 W  
**Voltage/Frequency** 110-120V 60Hz  
**Connection type** Hood comes standard with Nema 5-15P power cord

**BLOWER PERFORMANCE**

**Motor** 280 CFM  
**Minimum sound level** 0 dB (A)re1pW I.E.C. 60704-2-13  
**Maximum sound level** 0 dB (A)re1pW I.E.C. 60704-2-13

**WEIGHTS AND DIMENSIONS**

**Gross weight** 38 lbs  
**Net weight** 31 lbs  
**Volume** 7 ft  
**Packaging dimensions** L 28 x H 18 x D24 in

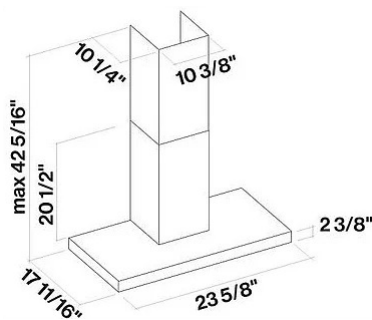

## **OPTIONAL ACCESSORIES**

<b>Code</b>	<b>Description</b>
KACL.815	Protective cleaning cloths for stainless steel (box 10 pcs)
103050107	FFCHASQC0BL - Square charcoal filter - Type 3
KACL.510#3	Extension kit h700 - Inox
KACL.512#3	KIT ACC. :EXTENSION FM LINE H=960mm INOX