

<b>Version</b>	FPMER36W3SS / Mercurio Wall 36" (90 cm) 280 CFM
<b>Collection</b>	Potenza



Photograph is for information purposes only. May not correspond to the selected version

**FEATURES AND PROPERTIES**

<b>Materials/Finishes</b>	Scotch brite stainless steel
<b>Control</b>	Electronic control
<b>Ducting type</b>	Extracting/Filtering
<b>Installation type</b>	Wall
<b>Lighting</b>	Led 2x1,2 W - 3200 K
<b>Filters</b>	Metallic grease filter, removable and washable Charcoal filter (optional)
<b>Ducting type</b>	
<b>Dimensions</b>	36 in
<b>Minimum Electric hob distance</b>	21 in
<b>Minimum Gas hob distance</b>	25 in

**ELECTRICAL CONNECTION AND CONSUMPTION**

<b>Maximum consumption</b>	150 W
<b>Voltage/Frequency</b>	110-120V 60Hz
<b>Connection type</b>	Hood comes standard with Nema 5-15P power cord

**BLOWER PERFORMANCE**

<b>Motor</b>	280 CFM
<b>Minimum sound level</b>	0 dB (A)re1pW I.E.C. 60704-2-13
<b>Maximum sound level</b>	0 dB (A)re1pW I.E.C. 60704-2-13

**WEIGHTS AND DIMENSIONS**

<b>Gross weight</b>	49 lbs
<b>Net weight</b>	35 lbs
<b>Volume</b>	11 ft
<b>Packaging dimensions</b>	L 40 x H 21 x D24 in

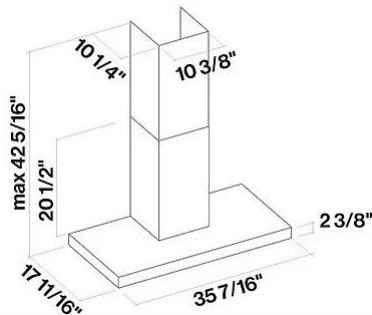

**OPTIONAL ACCESSORIES**

Code	Description
KACL.815	Protective cleaning cloths for stainless steel (box 10 pcs)

**OPTIONAL ACCESSORIES**

<i>Code</i>	<i>Description</i>
103050107	FFCHASQC0BL - Square charcoal filter - Type 3