



48" GLASS FROSTER



JOB
AREA
ITEM NO.
MODEL NO.

MODELS
FR48RT-SS-STK



FR48RT-SS-STK

KEY PRODUCT FEATURES AND BENEFITS

- Heavy duty construction – stainless steel interior and top
- 2" Foamed-in-place insulation provides energy savings using Ecomate(tm), a blowing agent that has zero-ozone depletion and zero global warming potential
- Unique door frame heater eliminates condensation build up on door
- All stainless steel interior front and sides with galvanized back
- Heavy gauge dent resistant doors
- Controller adjustable from -10°F - 10°F; Factory set at 0°F
- Manual 6-hour defrost system prevents interior ice buildup
- Floor racks standard; shelving must be ordered separately if needed (2 shelves recommended)
- Optional third shelf for 25% more glass storage
- Ultra quiet, high-efficiency, refrigeration system

Quick Features

- Plug-in installation, no condensate plumbing required
- 1 Year Parts and Labor Warranty, 5 Year Compressor Warranty



48" GLASS FROSTER

MODEL NUMBERS		FR48RT-SS-STK
EXTERIOR CABINET DIMENSIONS	Length - in. (mm)	48 (1219)
	Depth - in. (mm)	24 (610)
	Height - in. (mm)	34-1/8 (866)
INTERNAL NET VOLUME - cubic ft. (liters)		12.5 (353)
PLATE CAPACITY *		300 Plates
GLASS CAPACITY *		214 Glasses
W/ OPTIONAL THIRD SHELF		273 Glasses
SHIPPING WEIGHT LBS. (KG.)		300 (136)
CABINET CONSTRUCTION (INTERIOR)		All models have stainless steel walls and floor.
CABINET CONSTRUCTION (EXTERIOR)		Stainless Steel Option: Front and ends are stainless steel, back and bottom are galvanized.
DOORS AND HARDWARE		Sliding style open. Stainless steel top and bottom pans. Die cast handle
PLUMBING		No drain required. Condensate evaporates automatically.
INSULATION		2" Foamed-in-place insulation provides energy savings using Ecomate(tm), a blowing agent that has zero-ozone depletion and zero global warming potential.
VENTILATION		FR24 model is front vented, all other models require 2" clearance from wall on either left end or back of cabinet for proper air flow.
TEMPERATURE SPECIFICATIONS	Default Temperature Setpoint: Standard Temp Models - °F [°C]	0 [-17.75]
	Adjustable Setpoint Range: Standard Temp Models - °F [°C]	(-) 10 to (+)10 [-23.3 to -12.2]
ELECTRICAL SPECIFICATIONS	Supply	120 VAC/60 Hz/1 Ph
	Running Load Amps	3.8
	Power Cord	6-foot length with NEMA 5-15 plug.
	Thermostat	NSF Listed electronic control.
	Automatic Defrost	Automatic electric defrost every 4 hours for approximately 20 minutes.
REFRIGERATION SPECIFICATIONS	Manual Defrost	Push button defrost system, manually initiated at the end of each day. Automatically terminates after six hours.
	Condensing Unit	Hermetic condensing unit pulls out for service and cleaning.
	Expansion Device	Capillary Tube
	Refrigerant	R290
	Refrigerant Charge (g)	100
Compressor H.P.	1/4	
Total Heat of Rejection At 75°F ambient (BTU/h)	1625	
OPTIONAL ACCESSORIES		Flat shelving • Divider shelving • Roller basket shelving Set of 4 Adjustable legs (Multiple sizes available) Set of 4 Casters w/ brakes (Multiple sizes available) • 2', 3', 4', and 5' Bottle Rail (field Installed)

* Capacity based on use of 3" diameter glass and 9-1/2" diameter X 1/2" thick plate.

This product is evaluated by NSF for the chilling of glassware and plates. This product is not intended for the storage of food products.

! WARNING: California Prop 65 Notice

These products may expose you to chemicals including Chromium, which are known to the state of California to cause cancer and birth defects or other reproductive harm. For more information on whether a product in this list contains these chemicals, please refer to the specific product page at perlick.com. Or to find out more about Prop 65, go to P65Warnings.ca.gov.

Form No. Z2921
Rev. 06.08.23



48" GLASS FROSTER

48" CABINET

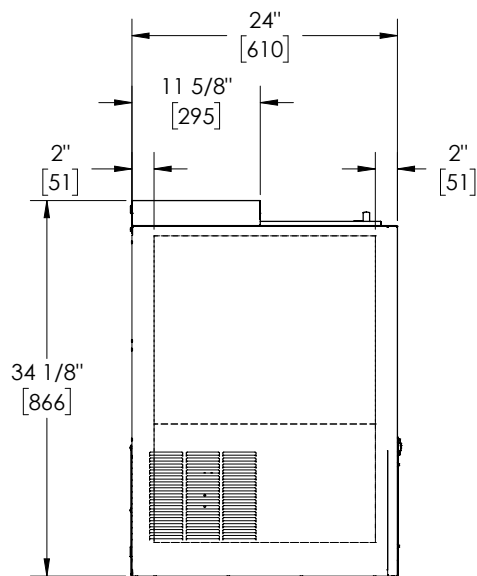

END VIEW*
36", 48", 60"
CABINET

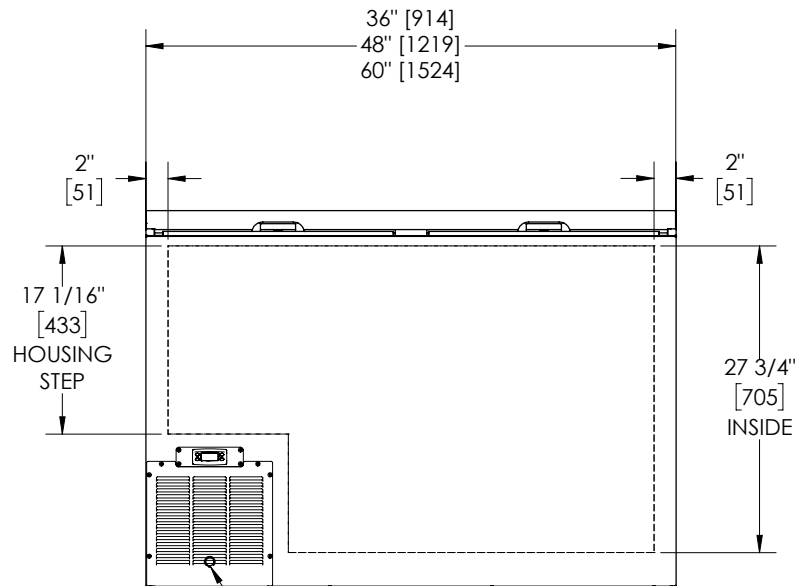

FRONT VIEW*
36", 48", 60"
CABINET

POWER CORD EXIT
(BACK OF UNIT)