

IR30450/S/P



FEATURES

The scratch-resistant, ceramic glass induction cooking surface offers consistent, precise temperature control and nearly instantaneous temperature adjustment response

Wolf's Dual VertiFlow™ convection system provides reliably even heat, reduces hot and cold spots, and enables consistent multi-rack cooking

Gourmet Mode features nearly 50 presets that automatically control the oven to ensure delicious results

Take the guesswork out of cooking with 10 chef-created cooking modes, including Bake, Broil, Convection, Convection Roast, Dehydrate, Gourmet, Proof, Roast, Stone, and Warm

The sleek rangetop features a striking interactive display. The full-color touchscreen is intuitive, easy to read, and locks for safety and cleaning

Boost Mode delivers rapid heat for lightning-fast boil times

The Bridge function joins two induction zones into one large area, enabling use of an induction-capable griddle, open roaster, or fish poacher

Because the cooktop stays relatively cool, spills don't stick to the surface—making cleanup a breeze

The oven offers self-clean, delayed start, timed cook, and Sabbath features

The temperature probe alerts you when your dish has reached the desired temperature

Control your oven from wherever you are using our convenient Owner's App—remotely preheat, adjust temperatures, select modes, and more

The range's stainless-steel construction and heavy-duty handles coordinate with a full suite of PRO-style Sub-Zero, Wolf, and Cove appliances

Achieve the bold look of a 60" induction range with two 30" units installed side by side and joined by a stainless-steel trim kit

ACCESSORIES

30" Broiler Pan and Rack

30" Dehydration Rack Set

30" Full-Extension Ball-Bearing Oven Rack

30" Multifunction Pan

30" Premier Baking Sheet

30" Standard Oven Rack

Bake Stone Kit

Filler Trim (2-pc)

Professional Dual Install Kit

Temperature Probe

Rear Caster Covers

Front Leg Extension Covers

Stainless Steel Kickplates

Accessories available through an authorized dealer.

For local dealer information, visit subzero-wolf.com/locator.



TOP CONFIGURATION

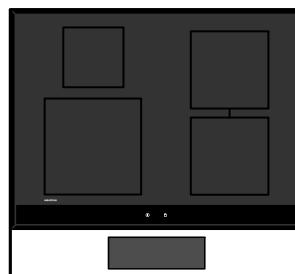

COOKTOP SPECIFICATIONS

- Four induction zones
- 1 - 6" 1,400 W Zone with 2,200 W Boost
- 2 - 8" 2,100 W Element with 3,700 W Boost
- 1 - 11" 2,600 W Zone with 3,700 W Boost

PRODUCT SPECIFICATIONS

Model	IR30450/S/P
Dimensions	29 7/8"W x 35 1/2"H x 29 1/2"D
Oven 1 Interior Dimensions	25 1/4"W x 17 1/2"H x 20"D
Oven 1 Usable Capacity	3.2 cu. ft.
Oven 1 Overall Capacity	5.1 cu. ft.
Door Clearance	21"
Weight	391 lbs
Electrical Supply	240/208 VAC, 60 Hz
Electrical Service	50 amp dedicated circuit

ELECTRICAL

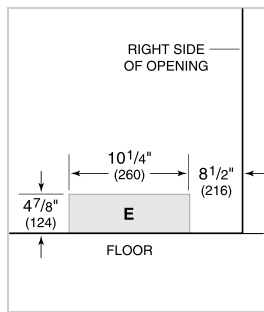

NOTE: Dimensions in parenthesis are in millimeters unless otherwise specified

DIMENSIONS

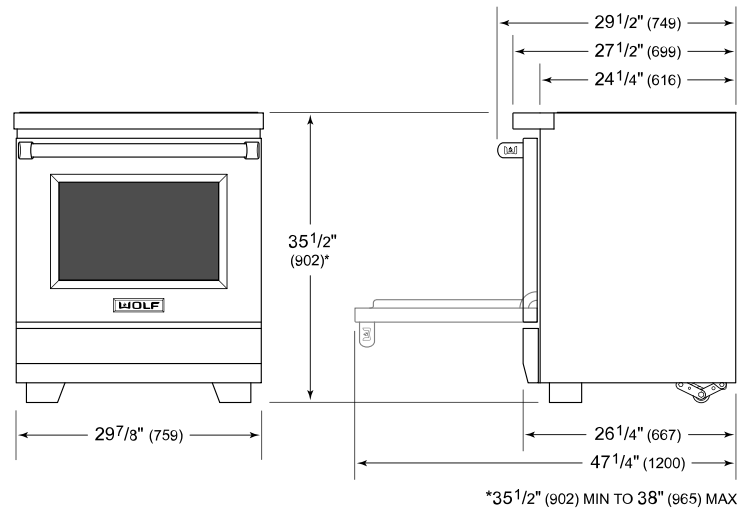

STANDARD INSTALLATION

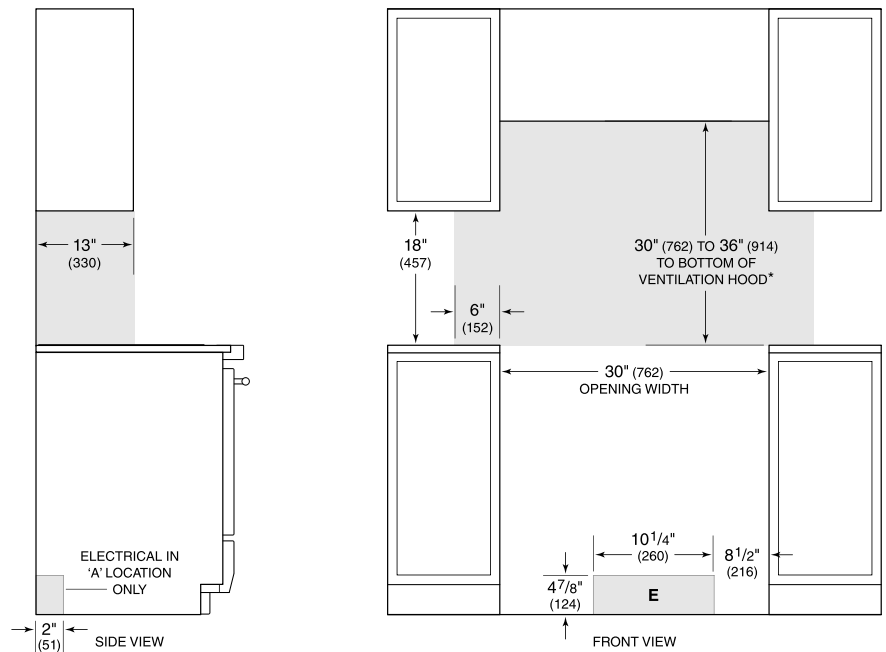

**Without ventilation hood, 36" (914) minimum clearance countertop to combustible materials.*

NOTE: Shaded area above countertop indicates minimum clearance to combustible surfaces, combustible materials cannot be located within this area.

For island installation, 12" (305) minimum clearance back of range to combustible rear wall above countertop.