

MAKE THE MOST OF YOUR



LN24REFC
OUTDOOR REFRIGERATOR / FREEZER
CARE & USE/INSTALLATION

CONTENTS

Contents

Safety information	2
Unpacking your appliance	3
Warranty registration	3
Installing your appliance	4
Cabinet clearances	4
Leveling the appliance	4
Electrical connection	5
Installing the water supply	6
Optional ice-maker operation	7
Product dimensions	8
Using your Electronic control	10
Shelving configurations	11
Shelf removal	12
Care and cleaning	13
Long term storage/winterization	13
Energy saving tips	16
Stainless steel maintenance	17
Obtaining service	17
Troubleshooting	18
Troubleshooting ice-maker	19
Warranty	20

Important Safety Instructions

Warnings and safety instructions appearing in this guide are not meant to cover all possible conditions and situations that may occur. Common sense, caution, and care must be exercised when installing, maintaining, or operating this appliance.

Recognize Safety Symbols, Words, and Labels.

Death or serious injury could result if...



WARNING

WARNING - You can be killed or seriously injured if you do not follow these instructions.



CAUTION

CAUTION-Hazards or unsafe practices which could result in personal injury or property / product damage.

NOTE

NOTE-Important information to help assure a problem free installation and operation.



WARNING

WARNING-This unit contains R600a (Isobutane) which is a flammable hydrocarbon. It is safe for regular use. Do not use sharp objects to expedite defrosting. Do not damage refrigerant circuit.



WARNING

State of California Proposition 65 Warning:
This product contains one or more chemicals known to the State of California to cause cancer.



WARNING

State of California Proposition 65 Warning:
This product contains one or more chemicals known to the State of California to cause birth defects or other reproductive harm.

UNPACKING YOUR APPLIANCE



WARNING

EXCESSIVE WEIGHT HAZARD

Use two or more people to move product.
Failure to do so can result in personal injury.

Remove Interior Packaging

Your appliance has been packed for shipment with all parts that could be damaged by movement securely fastened. Remove internal packing materials and any tape holding internal components in place. The owners manual is shipped inside the product in a plastic bag along with the warranty registration card, and other accessory items.

Important

Keep your carton and packaging until your appliance has been thoroughly inspected and found to be in good condition. If there is damage, the packaging will be needed as proof of damage in transit. Afterwards please dispose of all items responsibly.



WARNING

WARNING - Dispose of the plastic bags which can be a suffocation hazard.

Note to Customer

This merchandise was carefully packed and thoroughly inspected before leaving our plant. Responsibility for its safe delivery was assumed by the retailer upon acceptance of the shipment. Claims for loss or damage sustained in transit must be made to the retailer.

NOTE

DO NOT RETURN DAMAGED MERCHANDISE TO THE MANUFACTURER - FILE THE CLAIM WITH THE RETAILER.



CAUTION

If the appliance was shipped, handled, or stored in other than an upright position for any period of time, allow the appliance to sit upright for a period of at least 24 hours before plugging in. This will assure oil returns to the compressor. Plugging the appliance in immediately may cause damage to internal parts.

Warranty Registration

It is important you send in your warranty registration card immediately after taking delivery of your appliance or you can register online at:

www.lynxgrills.com/support/registration

The following information will be required when registering your appliance.

Service/Model Number

Serial Number

Date of Purchase

Dealer's name and address

The service/model number and serial number can be found on the serial plate which is located inside the cabinet on the left side near the top. (See Figure 1).

LYNX GRILLS, INC	
Greenwood, MS 38930	
MODEL NO.	<input type="text"/>
SERVICE NO.	<input type="text"/>
SERIAL NO.	XXXXXXXXXXXX
HZ <input type="text"/> VOLTS	<input type="text"/> AMPS <input type="text"/> R600A <input type="text"/> oz
DESIGN PRESSURES 140 PSI LOW SIDE 300 PSI HIGH SIDE	

Figure 1



WARNING

WARNING - Help Prevent Tragedies

Child entrapment and suffocation are not problems of the past. Junked or abandoned refrigerators are still dangerous - even if they sit out for "just a few hours".

If you are getting rid of your old refrigerator, please follow the instructions below to help prevent accidents.

Before you throw away your old refrigerator or freezer:

- Take off the doors or remove the drawers.
- Leave the shelves in place so children may not easily climb inside.

INSTALLING YOUR APPLIANCE

Select Location

The proper location will ensure peak performance of your appliance. We recommend a location where the unit will be out of direct sunlight and away from heat sources. To ensure your product performs to specifications, the recommended installation location temperature range is from 55 to 100°F (13 to 38°C).

Cabinet Clearance

Ventilation is required from the bottom front of the appliance. Keep this area open and clear of any obstructions. Adjacent cabinets and counter top can be installed around the appliance as long as the front grille remains unobstructed.

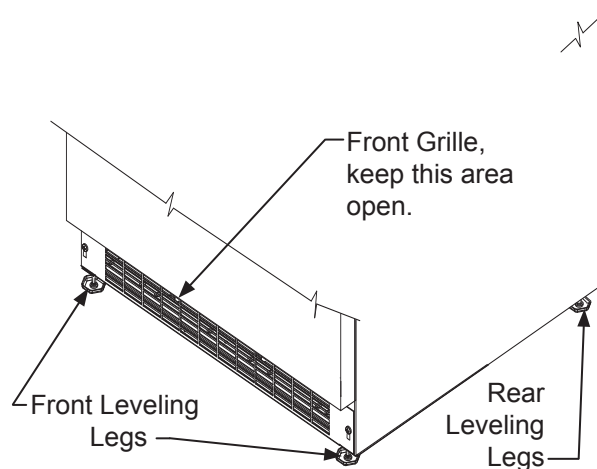

Figure 2

Leveling Legs

Adjustable legs at the front and rear corners of the appliance should be set so the unit is firmly positioned on the floor and level from side to side and front to back. The overall height of your appliance may be adjusted between the minimum, 33 $\frac{3}{4}$ " (85.7 cm), by turning the leveling leg in (CW ↻) and the maximum, 34 $\frac{3}{4}$ " (88.3 cm) by turning the leveling leg out (CCW ↻).

To adjust the leveling legs, place the appliance on a solid surface and protect the floor beneath the legs to avoid scratching the floor. With the assistance of another person, lean the appliance back to access the front leveling legs. Raise or lower the legs to the required dimension by turning the legs. Repeat this process for the rear by tilting the appliance forward using caution. On a level surface check the appliance for levelness and adjust accordingly.

The front grille screws may be loosened and the grille adjusted to the desired height. When adjustment is complete tighten the two front grille screws. (See Figure 5).



CAUTION

Front Grille

Do not obstruct the front grille. The openings within the front grille allow air to flow through the condenser heat exchanger. Restrictions to this air flow will result in increased energy usage and loss of cooling capacity. For this reason it is important this area not be obstructed and the grille openings kept clean. Lynx Grills does not recommend the use of a custom made grille as air flow may be restricted. (See Figure 2).

INSTALLING YOUR APPLIANCE

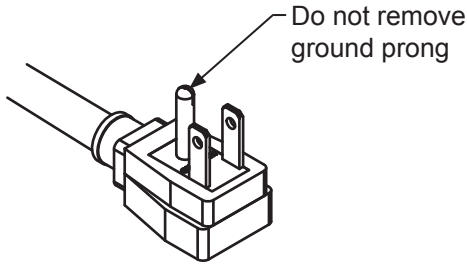

Figure 3

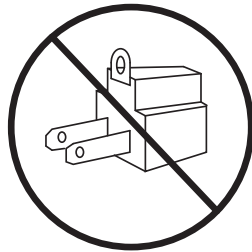

Figure 4

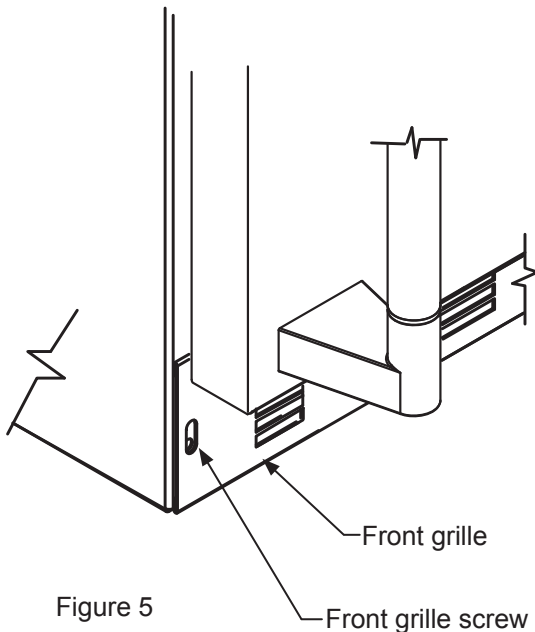

Figure 5

WARNING

Electrical Shock Hazard

- Do not use an extension cord with this appliance. They can be hazardous and can degrade product performance.
- This appliance should not, under any circumstances, be installed to an un-grounded electrical supply.
- Do not remove the grounding prong from the power cord. (See Figure 3).
- Do not use an adapter. (See Figure 4).
- Do not splash or spray water from a hose on the appliance. Doing so may cause an electrical shock, which may result in severe injury or death.

Electrical Connection

A grounded 115 volt, 15 amp dedicated circuit is required.

This product is factory equipped with a power supply cord that has a three-pronged, grounded plug. It must be plugged into a mating grounding type receptacle in accordance with the National Electrical Code and applicable local codes and ordinances (see Figure 6). If the circuit does not have a grounding type receptacle, it is the responsibility and obligation of the customer to provide the proper power supply. The third ground prong should not, under any circumstances, be cut or removed.

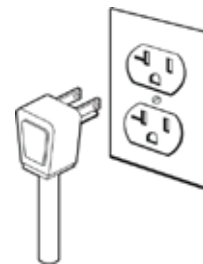

Figure 6

NOTE

Ground Fault Circuit Interrupters (GFCI) are prone to nuisance tripping which will cause the appliance to shut down. GFCI's are generally not used on circuits with power equipment that must run unattended for long periods of time, unless required to meet local building codes and ordinances.

INSTALLING THE WATER SUPPLY MODEL LN24REFC WITH OPTIONAL ICE-MAKER KIT

NOTE

An optional ice-maker kit (part number S42418151) is available for model LN24REFC which includes all of the necessary parts for installation. The kit can be obtained from Lynx Grills customer service by calling (888)-289-5969.

Water Supply

CAUTION

Observe and follow all local building codes when installing this appliance.

Use ¼" copper tubing for your water supply which is available at any local hardware or plumbing supply store. Bend the ¼" copper tubing to suit your installation being sure not to kink the tubing. Purchase enough copper tubing length and coil it behind the unit to form a "service loop" which will allow the appliance to be pulled out from the installation for servicing or cleaning. Connect the copper tubing to the "top side" of a cold water pipe to prevent the ice-maker from plugging with sediment.

A shutoff valve is recommended on the water supply line to ease servicing the appliance. **NOTE: A SELF-PIERCING TYPE VALVE IS NOT RECOMMENDED** as they are prone to clogging with sediment which will create pressure drop reducing the water supply to the unit.

Connect the copper tubing water supply to the brass union with the compression nut fitting provided. (See Figure 7).

Water pressure must be at a minimum of 20 psi for proper operation and a maximum of 120 psi.

Make certain all water connections are watertight after installation. Form the tubing so that it will not vibrate against the cabinet body or kink when your appliance is set in position.

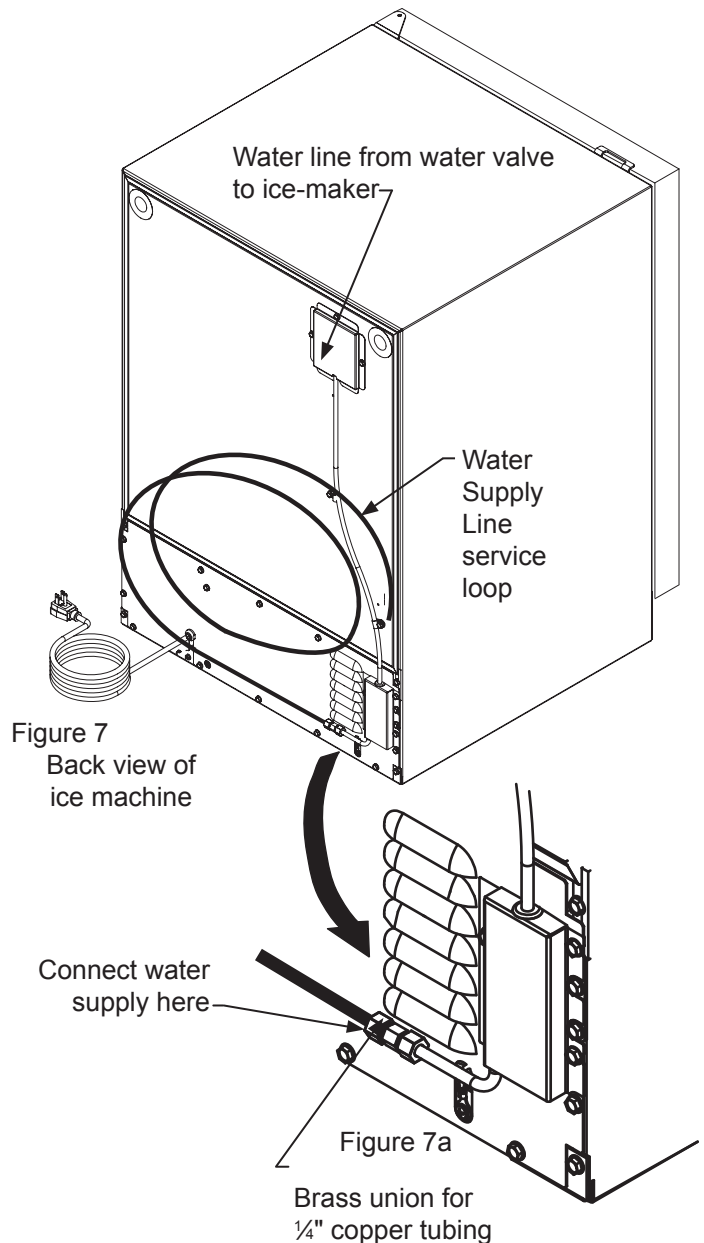

NOTE

- Do not use any thread sealers on these water line fittings.
- Reverse osmosis, softened water, and de-ionized water are not recommended as they will adversely affect the quality of the ice.

OPTIONAL ICE-MAKER OPERATION



CAUTION

The water supply to the ice-maker must be turned on prior to turning the ice-maker on. Failure to do so will cause rapid dry cycling of the ice-maker mold heater resulting in temperature control issues in the freezer compartment.

Ice-maker operation

- The unit must be installed level for proper ice-maker operation.
- The shutoff arm wire must be down in its lowest position for the ice-maker to operate. (See Figure 8).
- When the freezer section and ice-maker unit has sufficiently cooled, the ice-maker will harvest ice cubes automatically.
- When the ice bucket is full, the ice-maker will automatically shut off.
- You may manually stop the ice-maker by raising the shut off arm to the locking position at the up most position. (See Figure 8).

NOTE

It is recommended the ice-maker is shut off when removing the bucket, or ice may be dispensed onto the freezer compartment floor.

If the ice is not used regularly, it will clump together with time. For best ice results, discard ice in the bin as required and allow the ice-maker to make a new fresh batch of ice. Shut-off the ice-maker by raising the shut-off arm before removing the bucket.

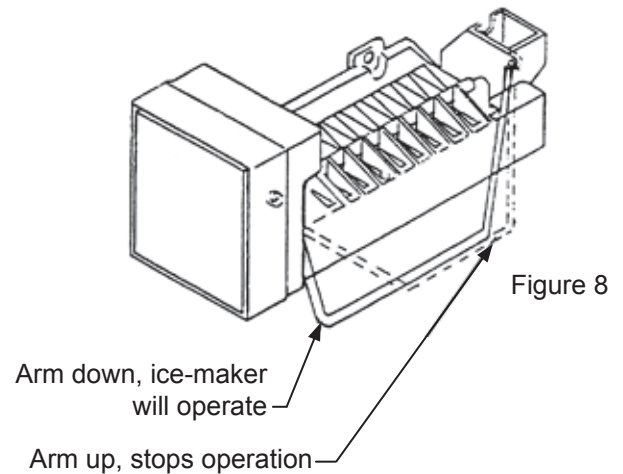

PRODUCT DIMENSIONS

MODEL	ROUGH-IN OPENING DIMENSIONS			CABINET DIMENSIONS					
	"A"	"B"	"C"	"D"	"E"	"F"	"G"	"H"	"J"
LN24REFC	24" (61 cm)	**34" to 35" (86.4 to 88.9 cm)	*	23 ⁷ / ₈ " (60.7 cm)	33 ³ / ₄ " to 34 ³ / ₄ " (85.7 to 88.3 cm)	23 ²³ / ₃₂ " (60.2 cm)	26 ³ / ₄ " (67.9 cm)	46 ¹³ / ₃₂ " (117.9 cm)	26 ³ / ₄ " (67.9 cm)

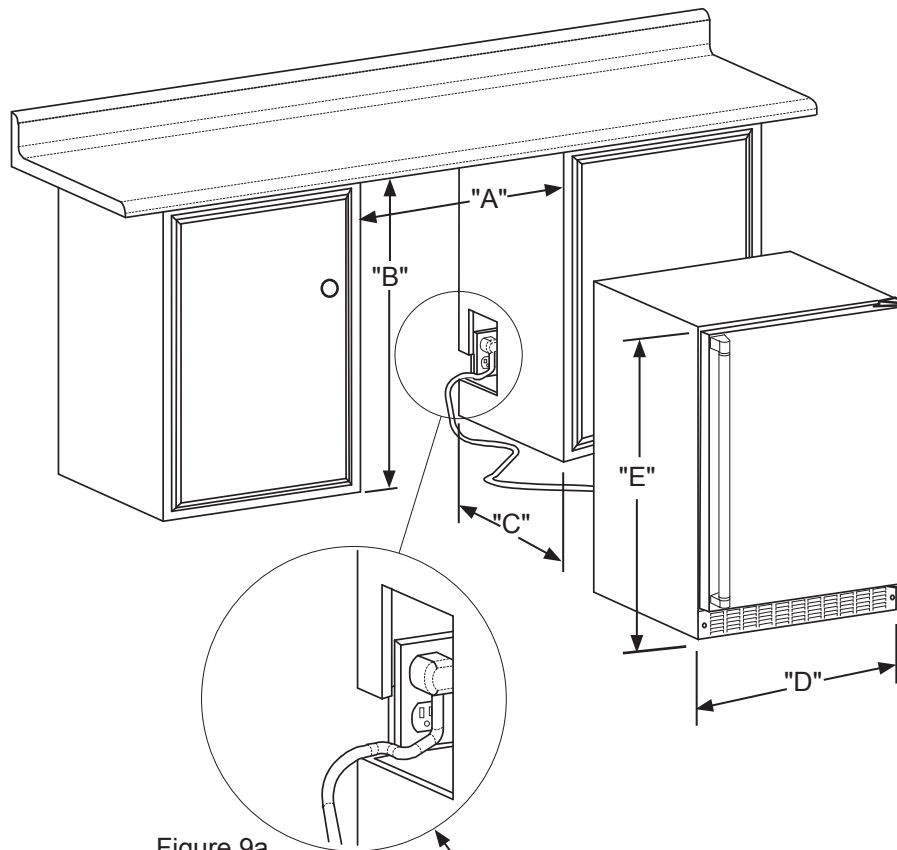

Figure 9

Figure 9a

If necessary to gain clearance inside the rough-in opening a hole can be cut through the adjacent cabinet and the power cord routed through this hole to a power outlet. Another way to increase the available opening depth is to recess the power outlet into the rear wall to gain the thickness of the power cord plug. Not all recessed outlet boxes will work for this application as they are too narrow, but a recessed outlet box equivalent to Arlington #DVFR1W is recommended for this application, (see Figure 10).



Figure 10

PRODUCT DIMENSIONS

MODEL	PRODUCT DATA	
	ELECTRICAL REQUIREMENTS #	PRODUCT WEIGHT
LN24REFC	115V/60Hz/15A	140 lbs (63.6 kg)

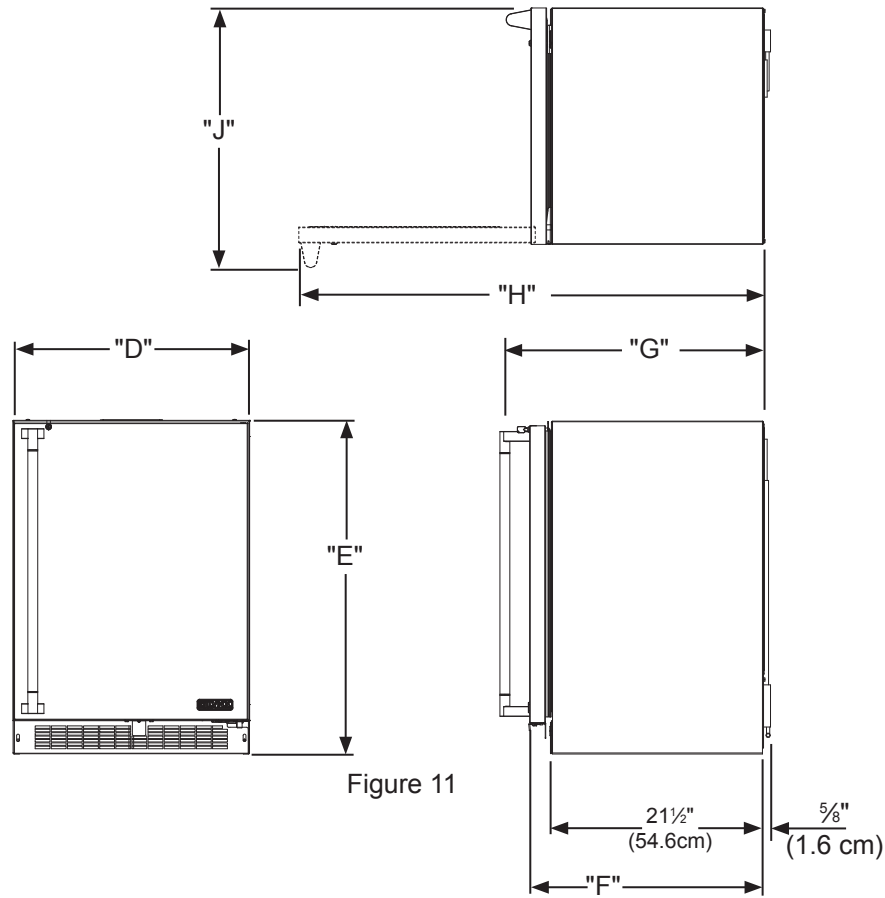

* Depth dimension of rough-in opening may vary depending on each individual installation. To recess entire door "F" dimension plus 1" (2.5 cm) for thickness of power cord plug.

** Minimum rough-in opening required is to be larger than the adjusted height of the cabinet.

A grounded 15 amp dedicated circuit is required. Follow all local building codes when installing electrical and appliance.

USING YOUR ELECTRONIC CONTROL

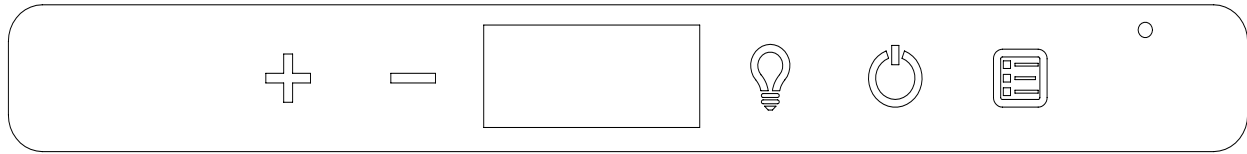

Figure 12
Electronic control

Control Function Guide

Function	Command	Notes
ON/OFF	Press and hold for 5 seconds.	Unit will immediately turn ON or OFF.
Adjust Temperature	Press or and release.	When the display is flashing, press or to adjust the set point temperature. Note: temperature displayed is the actual temperature inside unit.
Toggle Between °F / °C	Hold and for 5 seconds.	The display will change units.
Leave Interior Light On	Press and release to leave interior light on for 12 hours; press again to deactivate.	After 12 hours, factory default is restored; light will turn on when door is open.
Enable Sabbath Mode	Press and hold for 5 seconds and release.	The °F / °C symbol will flash briefly after 5 seconds. Interior light and display will go dark and remain so until user resets mode - unit continues to operate.
Disable Sabbath Mode	Press and release.	Display and interior light return to normal operation.

Door Alert Notification

When the door is left open for more than 5 minutes:

- will appear in display
- Close door to reset

High/Low Temp. Notifications

When the compartment temperature exceeds the control setting for an extended amount of time:

- “HH” will appear in display (High Temp)
- “LL” will appear in display (Low Temp)

Contact service dept. for further instructions.

NOTE

Temperature displayed reflects actual temperature inside unit. If the temperature displayed is different than selected, the unit is progressing towards the selected temperature. Time to reach set point varies based upon ambient temperature, temperature of product loaded, door openings, etc. Lynx Grills recommends allowing the unit to reach set points before loading.

SHELVING CONFIGURATIONS

Refrigerator / Freezer

24" (61 cm) wide see Figure 13:

Refrigerator:

- (2) Half width cantilever adjustable shelf.
see Figure 14
- (1) Full width fixed position glass shelf
- (1) Roller glide clear crisper drawer

Freezer:

- (1) Fixed position metal shelf, see Figure 15.

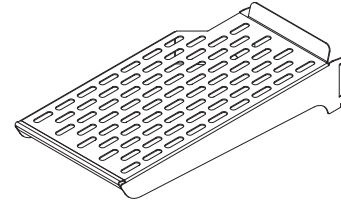

Figure 14

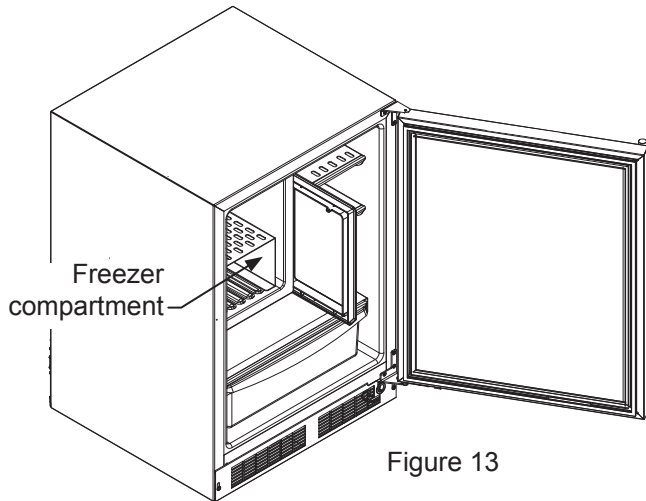

Figure 13

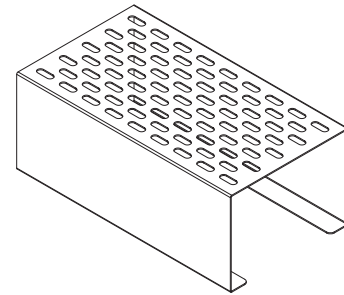

Figure 15
Freezer shelf

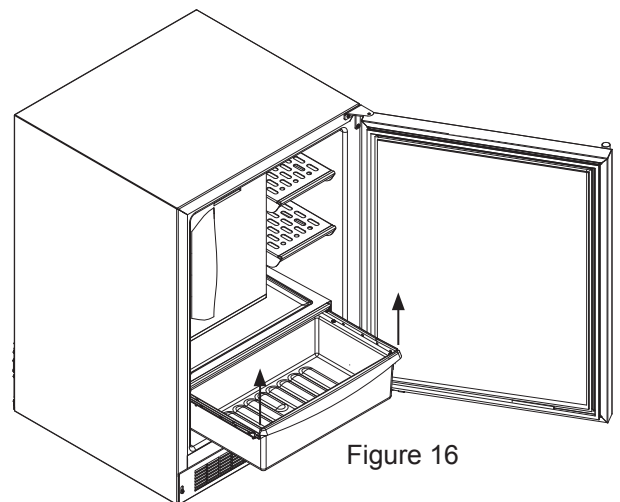

Figure 16

To remove the crisper :

Pull out until it stops. Lift up on the front of the pan, and remove it from the frame.

SHELF REMOVAL

To Add or Remove a Shelf

Remove stored product from the shelf. Do not try to remove a loaded shelf from the appliance. Grasp the shelf front with both hands, rotate the front upward and lift out. (See Figure 17a). To install a shelf insert the shelf in the appliance and insert the top hooks into the shelf support slots and drop the shelf down so the hooks drop over the bottom of the slots.



CAUTION

Make sure your cantilever shelf is secure on the shelf supports by pressing down on the shelf before loading.

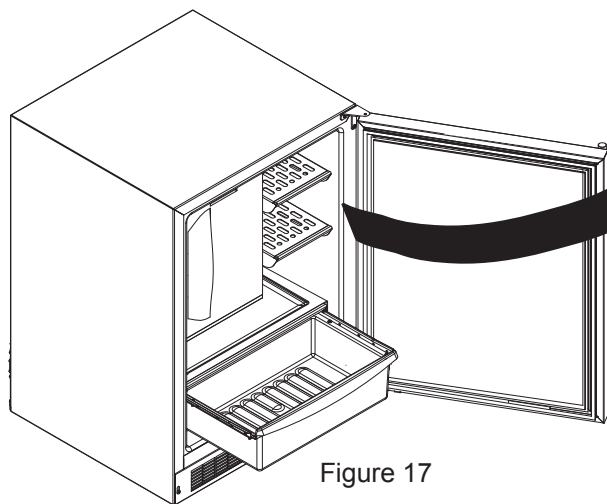

Figure 17

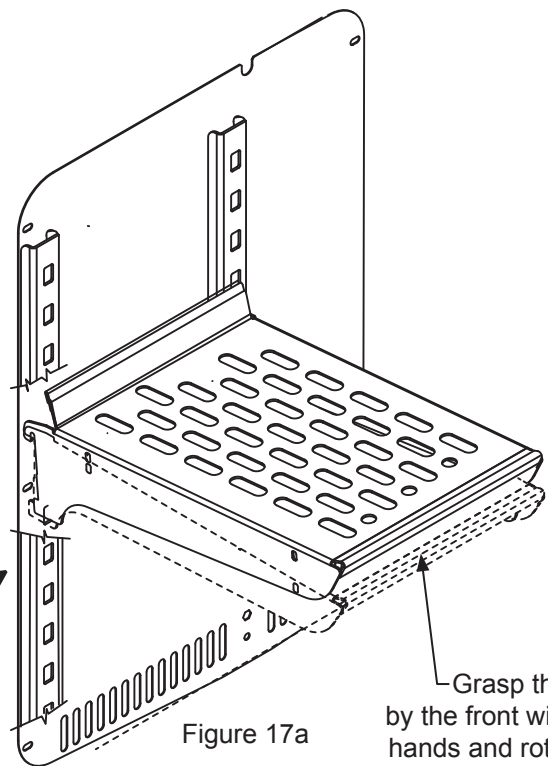

Figure 17a

Grasp the shelf by the front with both hands and rotate the front of the shelf up, then lift the shelf up and remove the shelf from the shelf ladders.



CAUTION

Never try to move a loaded shelf, remove everything from the shelf before moving. Use both hands when moving the shelf.

CARE AND CLEANING

Front Grille

Be sure that nothing obstructs the required air flow openings in front of the cabinet. At least once or twice a year, brush or vacuum lint and dirt from the front grille area (see page 4).



CAUTION

SHOCK HAZARD: Disconnect electrical power from the appliance before cleaning with soap and water.

Cabinet

The painted cabinet can be washed with either a mild soap and water and thoroughly rinsed with clear water. NEVER use abrasive scouring cleaners.

Interior

Wash interior compartment with mild soap and water. Do NOT use an abrasive cleaner, solvent, polish cleaner or undiluted detergent.

Care of Appliance

1. Avoid leaning on the door, you may bend the door hinges or tip the appliance.
2. Exercise caution when sweeping, vacuuming or mopping near the front of the appliance. Damage to the grille can occur.
3. Periodically clean the interior of the appliance as needed.
4. Periodically check and/or clean the front grille as needed.

In the Event of a Power Failure

If a power failure occurs, try to correct it as soon as possible. Minimize the number of door openings while the power is off so as not to adversely affect the appliance's temperature.

Light Assembly Replacement

All models use LED lamps to illuminate the interior of the appliance. This component is very reliable, but should one fail, contact a qualified service technician for replacement of the LED.

Long Term Storage/Winterization

(LN24REFC refrigerator freezer):

1. Time to Winterize, when the daily low ambient temperature is at or below 38°F (3.3°C).



CAUTION

Operation of the unit at ambient temperatures below the recommended Winterization temperature will void your warranty.

2. Turn unit off, (see page 10)
3. Remove all contents.
4. If necessary, move the unit so you can gain access to the rear of the product.
5. Unplug the unit from the power outlet.
6. It is also recommended that the power to the outlet be turned-off if the circuit is not required for other items during the Winter season.
7. When cleaning unit pay particular attention to any cracks and crevices that may have accumulated dirt and debris.
8. Remove the front toe-grille, (see Figure 18), and use a brush and vacuum to clean dirt and debris from beneath the unit.
9. Thoroughly clean the toe-grille and re-install on the unit. (See Figure 18).
10. Remove the rear access cover, (see Figure 19), and use a brush and vacuum to clean dirt and debris from the machine compartment.
 - If the plastic defrost drain pan located under the compressor contains water, use a sponge to remove as much water as possible.
11. Thoroughly clean the rear access cover and re-install on the unit.
12. Wipe down all interior surfaces with anti-bacterial cleaner to be followed with clean rinse water to remove any residual chemicals which could cause staining. Do not use any abrasive cleaners or scouring pads.
13. Leave the door open and allow to completely dry out before closing the door.
14. Thoroughly clean the door gasket with anti-bacterial cleaner to be followed with clean rinse water to remove any residual chemicals.
15. Thoroughly clean the exterior with a cleaner approved for stainless steel. Do not use any abrasive cleaners or scouring pads. See "Stainless Steel Maintenance" on page 17.
16. Any mounting hardware / fasteners that are showing signs of corrosion should be replaced.

CARE AND CLEANING

17. Once the exterior has been thoroughly cleaned, you may want to apply a coating of car wax to help protect against spotting from moisture, dirt, and debris that may accumulate on the surfaces during the Winterization period.
18. Do not place a cover on the unit, as this can trap condensation.

After completion of the above, you may choose to store the unit indoors, although this is not required.

Start-Up After Long-Term Storage

1. If stored outside, it is recommended that the unit again be thoroughly inspected per the storage instructions above to address any dirt or debris from the weather and/or animals/insects.
2. Connect the unit to electrical power.
3. Turn unit on and confirm your desired control settings.
4. Allow 24-hrs for the unit to stabilize before loading contents.

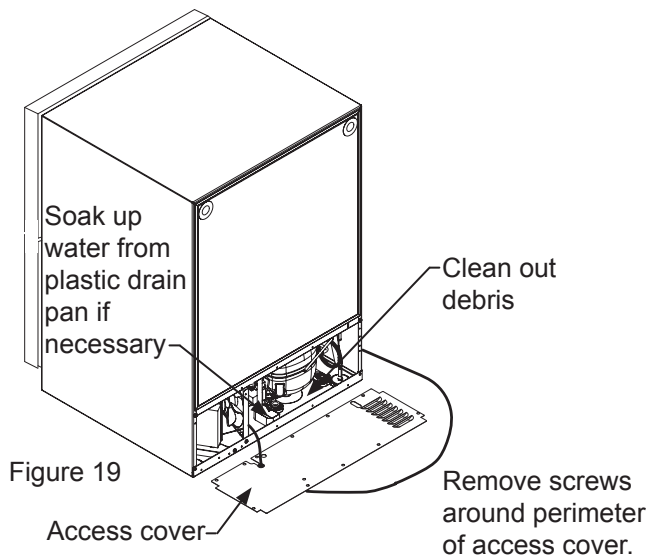
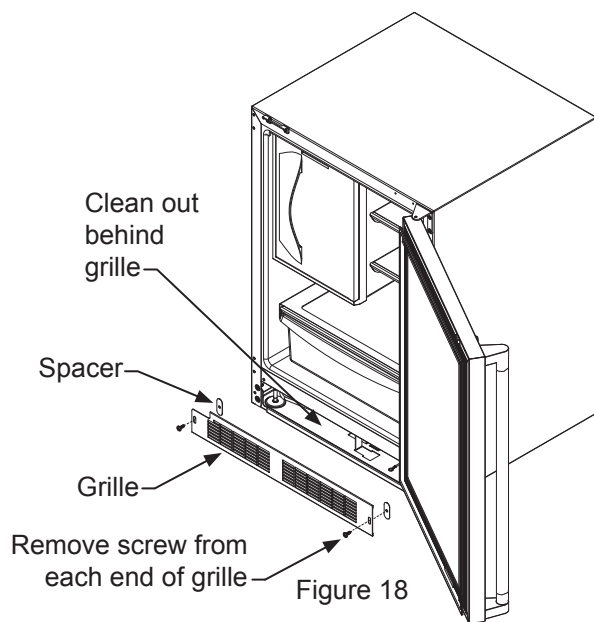

CARE AND CLEANING

Long Term Storage/Winterization

(LN24REFC, with optional ice maker):

1. Time to Winterize, when the daily low ambient temperature is at or below 38°F (3.3°C).

CAUTION

Operation of the unit at ambient temperatures below the recommended Winterization temperature will void your warranty.

2. Raise the bail arm of the ice maker (see Figure 8 on page 7) to stop ice production.
3. Turn the water supply to the unit off.
4. If necessary, move the unit so you can gain access to the rear of the product.
5. Disconnect the water supply line from the water fill valve located on the back of the unit, (see page 6).
6. Be sure the exterior water supply line is drained or blown out to prevent freezing and cracking of the supply line.
7. We recommend a cap be placed on the water supply line to prevent dirt and insects from plugging the line.
8. Empty the ice bucket and replace the ice bucket in unit.
9. Lower the ice maker bail arm to allow the unit to operate until ice is dispensed from ice maker to empty the ice maker mold.
10. Raise the bail arm and remove the ice bucket and clean thoroughly with warm water and dish soap.
11. Turn unit off to defrost ice storage compartment, see page 10).
12. Unplug the unit from the power outlet.
13. It is also recommended that the power to the outlet is turned-off if the circuit is not required for other items during the winter season.
14. When cleaning the unit pay particular attention to any cracks and crevices that may have accumulated dirt and debris.
15. Remove the front toe-grille, (see Figure 20), and use a brush and vacuum to clean dirt and debris from beneath the unit.
16. Thoroughly clean the toe-grille and re-install on the unit. (See Figure 20).
17. Remove the solenoid cover and 3 screws. (see Figure 21). Remove the rear access cover, (see Figure 21), and use a brush and vacuum to clean dirt and debris from the machine compartment.
 - If the plastic defrost drain pan located under the compressor contains water, use a sponge to remove as much water as possible.
18. Disconnect the plastic water line from the bottom of the solenoid valve (see Figure 21a) and drain. Reconnect the water line.
19. Thoroughly clean the rear access cover and re-install on the unit.
20. Wipe down all interior surfaces with anti-bacterial cleaner to be followed with clean rinse water to remove any residual chemicals which could cause staining. Do not use any abrasive cleaners or scouring pads.
21. Leave the door open and allow to completely dry out before closing the door.
22. Thoroughly clean the door gasket with anti-bacterial cleaner to be followed with clean rinse water to remove any residual chemicals.
23. Thoroughly clean the exterior with a cleaner approved for stainless steel. Do not use any abrasive cleaners or scouring pads. See "Stainless Steel Maintenance" on page 20.
24. Any mounting hardware / fasteners that are showing signs of corrosion should be replaced.
25. Once the exterior has been thoroughly cleaned, you may want to apply a coating of car wax to help protect against spotting from moisture, dirt, and debris that may accumulate on the surfaces during the Winterization period.

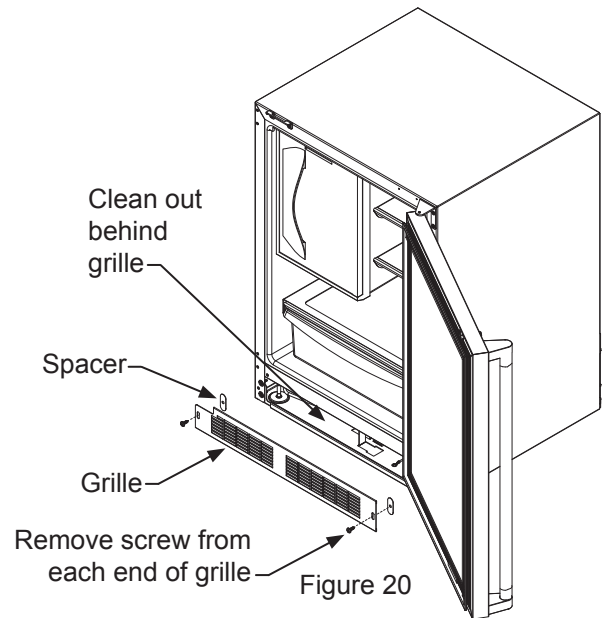

CARE AND CLEANING AND ENERGY SAVING TIPS

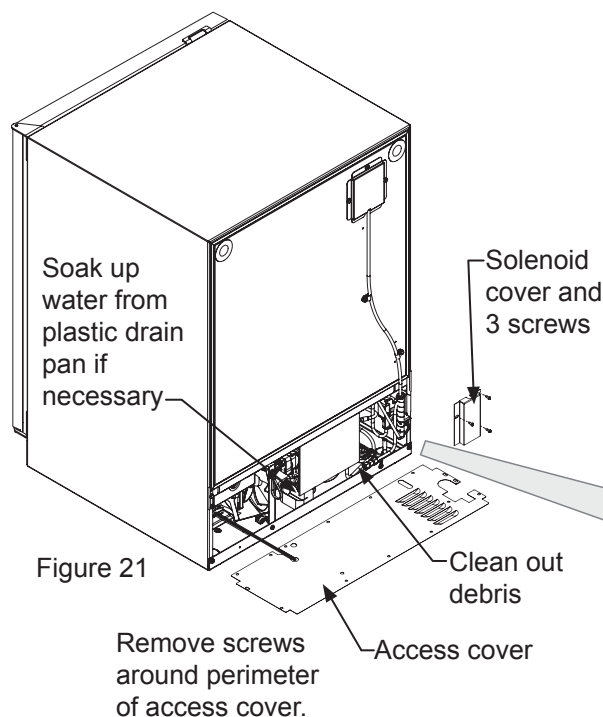

Figure 21

Start-Up After Long-Term Storage

1. If stored outside, it is recommended that the unit again be thoroughly inspected per the storage instructions above to address any dirt or debris from the weather and/or animals/insects.
2. Connect the unit to electrical power and the water supply.
3. Turn unit on and confirm your desired control settings.
4. Allow 24-hrs for the unit to stabilize before loading contents.

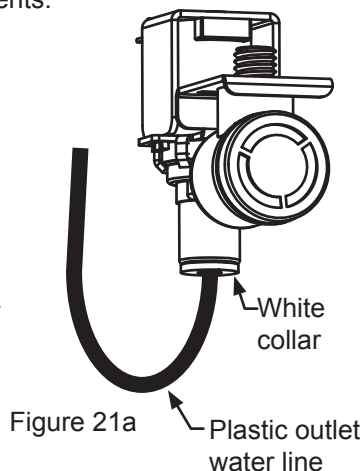

Figure 21a

To disconnect the water outlet line: Push up on the white collar and pull the plastic water line from the bottom of the water valve.

To reconnect the water outlet line: Simply insert the plastic tubing into the white collar and push until it stops (about ½", 12 mm, of water line will enter the valve).



CAUTION

The water supply to the ice-maker must be turned on prior to turning the ice-maker on. Failure to do so will cause rapid dry cycling of the ice-maker mold heater resulting in temperature control issues in the freezer compartment.

Energy saving tips

The following suggestions will minimize the cost of operating your refrigeration appliance.

1. Do not install your appliance next to a hot appliance (cooker, dishwasher, etc.), heating air duct, or other heat sources.
2. Install product out of direct sunlight.
3. Ensure the front grille vents at front of appliance beneath door are not obstructed and kept clean to allow ventilation for the refrigeration system to expel heat.
4. Plug your appliance into a dedicated power circuit. (Not shared with other appliances).
5. When initially loading your new product, or whenever large quantities of warm contents are placed within refrigerated storage compartment, minimize door openings for the next 12 hours to allow contents to pull down to compartment set temperature.
6. Maintaining a relatively full storage compartment will require less appliance run time than an empty compartment.
7. Ensure door closing is not obstructed by contents stored in your appliance.
8. Allow hot items to reach room temperature before placing in product.
9. Minimize door openings and duration of door openings.
10. Use the warmest temperature control set temperature that meets your personal preference and provides the proper storage for your stored contents.
11. When on vacation or away from home for extended periods, set the appliance to warmest acceptable temperature for the stored contents.
12. Set the control to the "off" position if cleaning the appliance requires the door to be open for an extended period of time.

STAINLESS STEEL MAINTENANCE OBTAINING SERVICE

Background

Stainless steel does not stain, corrode, or rust as easily as ordinary steel, but it is not stain or corrosion proof. Stainless steels can discolor or corrode if not maintained properly.

Stainless steels differ from ordinary carbon steels by the amount of chromium present. It is this chromium that provides an invisible protective film on the surface called chrome-oxide. This protective chrome-oxide film on the surface can be damaged or contaminated, which may result in discoloration, staining, or corrosion of the base metal.

Care & Cleaning

Routine cleaning of the stainless steel surfaces will serve to greatly extend the life of your product by removing contaminants. This is especially important in coastal areas which can expose the stainless to severe contaminants such as halide salts, (sodium chloride).

It is strongly recommended to periodically inspect and thoroughly clean crevices, weld points, under gaskets, rivets, bolt heads, and any locations where small amounts of liquid could collect, become stagnant, and concentrate contaminants. Additionally, any mounting hardware that is showing signs of corrosion should be replaced.

Frequency of cleaning will depend upon the installation location, environmental, and usage conditions.

Choosing a Cleaning Product

The choice of a proper cleaning product is ultimately that of the consumer, and there are many products from which to choose. Depending upon the type of cleaning and the degree of contamination, some products are better than others.

Typically the most effective and efficient means for routine cleaning of most stainless steel products is to give the surfaces a brisk rubbing with a soft cloth soaked in warm water and a gentle detergent, or mild mixture of ammonia. Rubbing should, to the extent possible, follow the polish lines of the steel, and always insure thorough rinsing after cleaning.

Although some products are called "stainless steel cleaners," some may contain abrasives which could scratch the surface, (compromising the protective chrome-oxide film), and some many contain chlorine bleach which will dull, tarnish or discolor the surface if not completely removed.

After the stainless surfaces have been thoroughly cleaned, a good quality car wax may be applied to help maintain the finish.

NOTE

Stainless steel products should never be installed, or stored in close proximity to chlorine chemicals.

Whichever cleaning product you chose, it should be used in strict accordance with the instructions of the cleaner manufacturer.

If Service is Required

- If the product is within the first year warranty period please contact your dealer or call Lynx Grills Customer Service at 888.289.5969 for directions on how to obtain warranty coverage in your area.
- If the product is outside the first year warranty period, Lynx Grills Customer Service can provide recommendations of service centers in your area.
- In all correspondence regarding service, be sure to give the service/model number, serial number, and proof of purchase.
- Try to have information or description of nature of the problem, how long the appliance has been running, the room temperature, and any additional information that may be helpful in quickly solving the problem.
- Table "A" is provided for recording pertinent information regarding your product for future reference.

For Your Records	
Date of Purchase	
Dealer's name	
Dealer's Address	
Dealer's City	
Dealer's State	
Dealer's Zip Code	
Appliance Serial Number	
Appliance Service/Model Number	
Date Warranty Card Sent (Must be within 10 days of purchase).	

Table A

TROUBLESHOOTING

Before You Call for Service

If the appliance appears to be malfunctioning, read through this manual first. If the problem persists, check the troubleshooting guide below. Locate the problem in the guide and refer to the cause and its remedy before calling for service. The problem may be something very simple that can be solved without a service call. However, it may be required to contact your dealer or a qualified service technician.



CAUTION

In the unlikely event you lose cooling in your unit, **do not unplug the product from the electric supply**, but do call a qualified service technician immediately. It is possible that the loss of cooling capacity is a result of excessive frost build-up on the evaporator cooling coil. In this case, removing power to the unit will result in the melting of this excessive quantity of ice, which could generate melt water that exceeds the capacity of the defrost drain system and could result in water damage to your home. The end-user will be ultimately responsible for any water damage caused by prematurely turning the unit off without appropriately managing the excess water run-off.

NOTE

Your product has an automatic defrost feature that utilizes an electric heater element. Periodically during defrost you may observe the following:

- Water dripping and running sounds as a result of the frost melt.
- Sizzling and popping sounds from water dripping on the heater element.
- A faint reddish glow in the freezer compartment from the electric heater element.

These are all “normal” operating characteristics related to refrigeration product incorporating automatic defrost. They do not represent any product fault or safety issue.



WARNING

Electrocution Hazard

- Never attempt to repair or perform maintenance on the appliance until the main electrical power has been disconnected. Turning the appliance control "OFF" does not remove electrical power from the unit's wiring.
- Replace all parts and panels before operating.

Problem	Possible Cause	Remedy
Appliance not cold enough (See "Adjusting the temperature" on page 10)	<ul style="list-style-type: none"> • Control set too warm • Content temperature not stabilized. • Excessive usage or prolonged door openings. • Airflow to front grille blocked. • Door gasket not sealing properly. 	<ul style="list-style-type: none"> • Adjust temperature colder. Allow 24 hours for temperature to stabilize. • Allow temperature to stabilize for at least 24 hours. • Airflow must not be obstructed to front grille. See "clearances" on page 4. • Replace door gasket.
Appliance too cold (See "Adjusting the Temperature" on page 10)	<ul style="list-style-type: none"> • Control set too cold • Door gasket not sealing properly. 	<ul style="list-style-type: none"> • Adjust temperature warmer. Allow 24 hours for temperature to stabilize. • Replace door gasket.
No interior light.	<ul style="list-style-type: none"> • Failed LED light assembly or light switch. 	<ul style="list-style-type: none"> • Contact a qualified service technician.
Light will not go out when door is closed	<ul style="list-style-type: none"> • Door not activating light switch. • Failed light switch 	<ul style="list-style-type: none"> • Appliance not level, level appliance, (See page 4, "leveling legs") • Contact a qualified service technician.
Noise or Vibration	<ul style="list-style-type: none"> • Appliance not level • Fan hitting tube obstruction. 	<ul style="list-style-type: none"> • Level appliance, see "Leveling Legs" on page 4. • Contact a qualified service technician.
Appliance will not run.	<ul style="list-style-type: none"> • Appliance turned off • Power cord not plugged in. • No power at outlet. 	<ul style="list-style-type: none"> • Turn appliance on. See "Starting your appliance" on page 10. • Plug in power cord. • Check house circuit.

TROUBLESHOOTING OPTIONAL ICE-MAKER

Problem	Possible Cause	Remedy
Unit operates but produces little or no ice.	<ul style="list-style-type: none"> The unit has just been started and it has been less than 24 hours. 	<ul style="list-style-type: none"> Typical ice production is 6 to 7 pounds per day. Allow for the freezer section to reach temperature and the ice-maker to cycle and accumulate ice.
	<ul style="list-style-type: none"> Water supply is not turned on. 	<ul style="list-style-type: none"> Turn on water supply to the unit.
	<ul style="list-style-type: none"> Inadequate water pressure to unit. 	<ul style="list-style-type: none"> Water pressure to the unit must be at a minimum of 20 psi.
	<ul style="list-style-type: none"> The ice-maker shut off arm is in the uppermost / off position. 	<ul style="list-style-type: none"> When the ice-maker shut off arm is in the uppermost position, the ice-maker is off. Flip the shut off arm down to turn on the ice maker.
	<ul style="list-style-type: none"> Freezer section has not reached temperature. 	<ul style="list-style-type: none"> Allow the freezer section to reach temperature.
	<ul style="list-style-type: none"> Thermostat control set too warm. 	<ul style="list-style-type: none"> Turn the temperature control to a higher number to allow the unit to run colder. Allow 24 hours before readjusting the temperature control.
	<ul style="list-style-type: none"> Condenser fan air flow is restricted. 	<ul style="list-style-type: none"> Make certain the grille in front of the unit is free and open for air circulation. Clean grille as required.
	<ul style="list-style-type: none"> Room and/or water temperature is too warm. 	<ul style="list-style-type: none"> Move the unit to an area where ambient temperature is below 115°F. The unit should not be placed next to a heat source such as an oven. Check for cold water connection.
Small ice cubes	<ul style="list-style-type: none"> Water input may require adjustment. 	<ul style="list-style-type: none"> Due to differing water pressures, the ice-maker water input may require adjustment. Contact a qualified service technician.
	<ul style="list-style-type: none"> The water pressure is too low. 	<ul style="list-style-type: none"> The water supply line is kinked. Sediment build-up in supply line.
Ice cubes are sticking together.	<ul style="list-style-type: none"> Ice consumption is low. 	<ul style="list-style-type: none"> Ice will stick together if stored for long periods of time.
	<ul style="list-style-type: none"> Hollow ice cubes with liquid centers that break when dispensed into the bucket. 	<ul style="list-style-type: none"> Ice-maker malfunction, call for service.

HOUSEHOLD PRODUCT WARRANTY

UNDERCOUNTER REFRIGERATOR / BEVERAGE CENTER WARRANTY

ONE YEAR FULL WARRANTY

Undercounter refrigerators / Beverage Centers and all of their component parts, **except as detailed below**†**, are warranted to be free from defective materials or workmanship in normal residential use for a period of one (1) year from the date of original retail purchase. Lynx, warrantor, agrees to repair or replace, at its option, any part which fails or is found to be defective during the warranty period.

***FULL NINETY (90) DAY COSMETIC WARRANTY:** Product is warranted to be free from cosmetic defects in materials or workmanship (such as scratches on stainless steel, paint/porcelain blemishes, etc.) for a period of ninety (90) days from the date of original retail purchase or closing date for new construction, whichever period is longer. Any defects must be reported to the selling dealer within ninety (90) days from date of original retail purchase. Lynx uses high quality processes and materials available to produce all color finishes. However, slight color variation may be noticed because of the inherent differences in painted parts and porcelain parts as well as differences in kitchen lighting, product locations, and other factors. Therefore, this warranty does not apply to color variation attributable to such factors.

†FULL NINETY (90) DAY WARRANTY IN "RESIDENTIAL PLUS" APPLICATIONS: Lynx products are designed and certified for residential use only. They are not intended for use in commercial applications. Lynx products should only be used in accordance to national and local codes. Lynx is not responsible for property damage or injury resulting from use in a commercial application. To support the manufacturing quality of its appliance's Lynx will provide a full 90 day warranty for products used in "Residential Plus" applications. This "Residential Plus" warranty applies to applications where use of the product extends beyond residential use but is in compliance with national and local code. In some jurisdictions these applications are zoned as residential. Examples of, but not limited to, such applications covered by this warranty are bed and breakfasts, fire stations, private clubs, churches, condominium/apartment common areas etc. Under this "Residential Plus" warranty, the product, its components and accessories are warranted to be free from defective material or workmanship for a period of ninety (90) days from the date of original retail purchase. Lynx warrantor agrees to repair or replace, at its option, any part which fails or is found to be defective during the warranty period. This warranty covers parts and labor. **This warranty excludes use of the product in all commercial locations such as restaurants, food service locations and institutional food service locations.**

TWO YEAR LIMITED WARRANTY ON SEALED REFRIGERATION PARTS AS LISTED

Any sealed refrigeration system component, as listed below, which fails due to defective materials or workmanship in normal household use during the second year from the date of original retail purchase will be repaired or replaced, free of charge for the part itself, with the owner paying all other costs, including labor.

Sealed Refrigeration System Components: Compressor, Evaporator, Condenser, Connecting Tubing, Dryer/Strainer

WARRANTY TERMS

This warranty extends to the original retail purchaser of the product warranted hereunder and to each transferee owner of the product during the term of the original purchaser's warranty. The warranty is transferable by the original retail purchaser via home sale only. If a transferee owner is unable to provide proof of purchase from the original purchaser and the product has not been previously registered, the production date of the product, located in the serial number of the product, will serve as the effective warranty start date.

The activation date of the warranty begins from the date of original retail purchase. In the case of new product purchase via building development sales, activation begins from the earlier date of either certificate of occupancy or 24 months from date of manufacture. Note date of manufacture is identified by serial tag on product.

This warranty does not cover units purchased as b-stock, liquidation, salvage, seconds, refurbished, as-is, used products.

This warranty shall apply to products purchased in the United States and Canada. Products must be purchased in the country where service is requested. Warranty service must be performed by a Lynx authorized service agency or representative. Warranty shall not apply to damage resulting from abuse, accident, natural disaster, loss of electrical power to the product for any reason, alteration, improper installation, improper operation, or repair service of the product by anyone other than a Lynx authorized service agency or representative. This warranty does not apply to commercial usage. Warrantor is not responsible for consequential or incidental damage whether arising out of breach of warranty, breach of contract or otherwise. Some jurisdictions do not allow the exclusion or limitation of incidental or consequential damages, if so, the above limitations do not apply to you.

Owner shall be responsible for proper installation, providing normal care and maintenance, providing proof of purchase upon request, and making the product reasonably accessible for service. If the product or one of its component parts contains a defect or malfunction during the warranty period, after a reasonable number of attempts by the warrantor to remedy the defects or malfunctions, the owner is entitled to either a refund or replacement, at the warrantor's discretion of the product or its component part or parts. Warrantor's liability on any claim of any kind, with respect to the goods or services covered hereunder, shall in no case exceed the price of the goods or service or part thereof which gives rise to the claim.

WARRANTY SERVICE

Under the terms of this warranty, service must be performed by a Lynx authorized service agent or representative. Service will be provided during normal business hours. Labor performed at overtime or premium rates shall not be covered by the warranty. To obtain warranty service contact Lynx Customer Care at 1-888-289-5969. Please have model number, serial number, and date of original purchase available when calling. **IMPORTANT:** Retain proof of original purchase to establish warranty period. The return of the owner registration card is not a condition of warranty coverage. You should, however, return the owner registration card so Lynx can contact you should any question of safety arise which could affect you. Any implied warranties of merchantability and fitness applicable to the above described and stainless steel parts are limited in duration to the period of coverage of the applicable express written limited warranties set forth above. Some jurisdictions do not allow limitations on how long an implied warranty lasts, if so, the above limitations may not apply to you. This warranty gives you specific legal rights, and you may also have other rights which may vary from jurisdiction to jurisdiction.

Specifications subject to change without notice.



The best outdoor kitchen products come from:
Lynx Grills
62201 Highway 82 West Greenwood, MS 38930
Service: (888)-289-5969
www.lynxgrills.com