



30-Inch Wide Double Wall Oven

MEW9630F



Fingerprint Resistant Stainless Steel
MEW9630FZ

Capacity	
Oven	10.0 cu. ft.
General Features & Properties	
Precision Cooking™ System	
Heavy-Duty Roll-Out Racks	
2x Life Heavy Duty Door Hinges	
Variable Broil	
10 Year Limited Parts Warranty*	
Designed, Engineered, and Assembled in the USA	
Fingerprint Resistant Stainless Steel	
Electrical Details	
Amps	40
Volts	240

Technical Details	
Fuel Type	Electric
Oven Type	Double
Oven Cooking System	Convection Upper Oven/ Thermal Lower Oven
Number of Oven Racks	3 Upper Oven 2 Lower Oven
Cleaning Type	Adjustable Self-Cleaning
Dimensions	
Product Dimensions (H x W x D)	51-3/16" x 30" x 26-7/8"
Depth with Door Open 90°	45-1/2"
Cutout Dimensions (H x W x D)	50-1/4" x 28-1/2" x 24"

Reference Material

[Dimension Guide](#)

[Install Guide](#)

[Use & Care Guide](#)

[Warranty](#)

Also available in:

- White **MEW9630FW**
- Black **MEW9630FB**

Key Features & Benefits

Power Preheat

Power Preheat lets you enjoy dinner faster with juicy flavor every time.

True Convection with Fan & Third Element

True convection uses a powerful third heating element and a sturdy fan to circulate even temperatures for more consistent roasting and baking.

FIT System

The innovative FIT system ensures your new Maytag® wall oven will fit your kitchen cabinet.

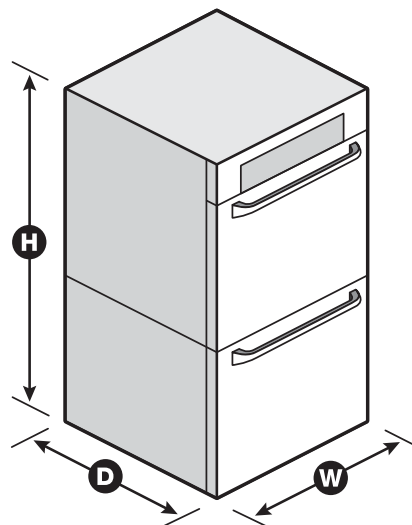

*Visit maytag.com for warranty details. NOTE: Dimensions are for planning purposes only. For complete details, see Installation Instructions packed with product. Specifications subject to change without notice.