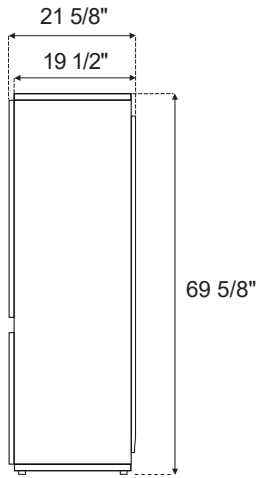
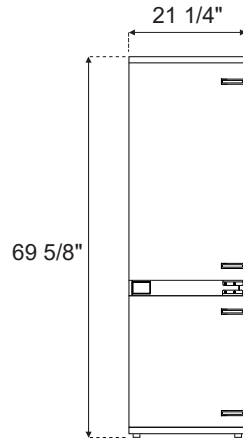
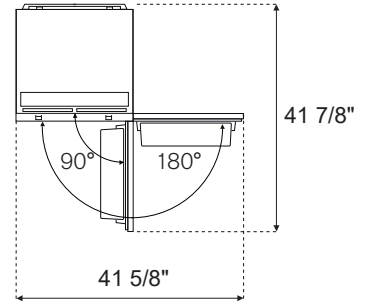
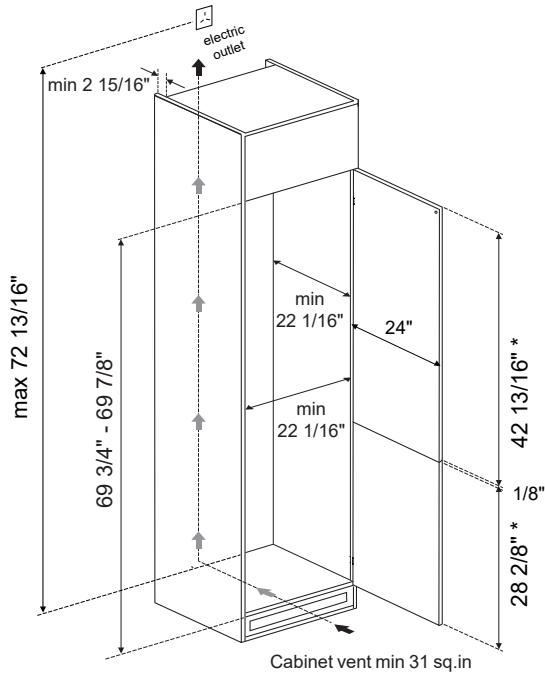
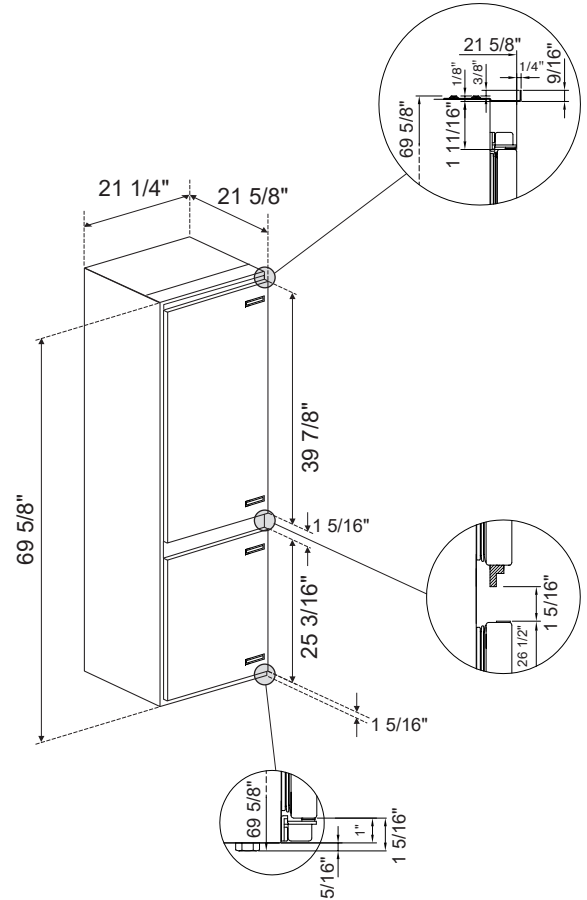

SIDE**FRONT****TOP****CUTOUT DIMENSIONS**

* Indicative panel height, to be adjusted according to cabinet specifications.

The refrigerator is installed on the cabinet base shelf and not kitchen floor.
Max weight for the cabinet panels is 37.5 lbs per panel.

**ELECTRICAL CONNECTION**

A properly-grounded, electrical receptacle should be installed. A separate circuit breaker servicing only this appliance is recommended. Do not use a multi-purpose socket with other electrical appliances.

TOP VIEW