

# RS600FZ6I

60 cm, FREEZER, 0FZ Model

BUILT-IN

DESIGNER® SERIE

*Fhiaba*



## FEATURES

- Made in Italy
- OptiView™: OptiView LED lights
- EventLift™: Easily rearrange the shelving without removal using the EvenLift system
- ProVent™: Uniform air circulation maintains consistent temperatures throughout the appliance resulting in better food preservation
- Anti-bacterial Stainless Steel Interiors Drawers: Achieve the highest food quality by storing food in the stainless steel interiors & drawers that shields against the spread of bacteria
- Total No Frost: Temperature control helping mitigate cooling loss when opening the refrigerator door. No more frost build-up that requires defrosting
- Ice Maker: Get high-quality ice cubes in a variety of sizes
- Water Filter: Get pure water and crystal-clear ice thanks to the integrated water filter and ice maker
- SuperIce™: Temporarily increase ice cube production for gatherings and parties
- Ice Size: Easily switch between medium and large ice cubes
- EquiLance™: Achieve a seamless built-in look with Fhiaba's innovative door hinge

## GENERAL PROPERTIES

|   |           |
|---|-----------|
| Equilance Hinge                         | YES       |
| Soft-Closing Glides                     | YES       |
| Low Vibration                           | YES       |
| OptiView (Led Light Spots)              | YES       |
| Shelves                                 | 2         |
| Type Of Shelves                         | glass     |
| Door Bins                               | 2         |
| Fridge Interior Drawers                 | /         |
| Freezer Drawers                         | 4         |
| Evenlift Shelves                        | YES       |
| Full Extension Shelves 90° Door Opening | NO        |
| Full Extension Drawers 90° Door Opening | NO        |
| Defrost Process                         | AUTOMATIC |
| Ice Maker With Water Filter             | YES       |
| Door Open Alarms                        | YES       |
| Shopping Fridge                         | NO        |
| Shopping Freezer                        | YES       |
| Power Failure Alert                     | YES       |
| Water Dispenser With Water Filter       | NO        |

# RS600FZ6I

60 cm, FREEZER, 0FZ Model

BUILT-IN

DESIGNER® SERIE

## PRODUCT DETAIL

# Fhiaba

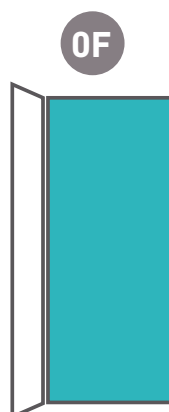
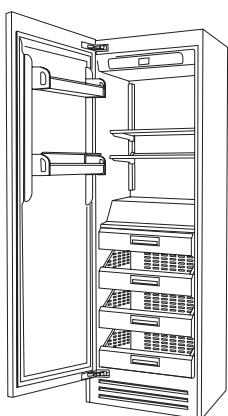

1D | 1M

freezer

D = door

M = separate microclimates

### CAPACITY

|   |     |
|---|-----|
| Volume Compartment 1 (L)                              | /   |
| Volume Compartment 2 (L)                              | /   |
| Volume Compartment 3 (L)                              | 348 |
| Total Net Volume (L)                                  | 348 |
| Total Gross Volume (L)                                | 350 |
| Compartment 1 / Upper wine cellar capacity (bottles)  | /   |
| Compartment 2 / Lower wine cellar capacity (bottles)  | /   |
| Compartment 3 / Bottom wine cellar capacity (bottles) | /   |

### TECHNICAL DETAILS

|                                      |                               |
|--------------------------------------|-------------------------------|
| Total absorbed current (A)           | 1.5                           |
| Voltage (V)                          | 220-240V                      |
| Frequency (Hz)                       | 50/60 Hz                      |
| Power Cord Length (mm)               | 2                             |
| Plug Type                            | Tipo F (Schuko) 16A IEC13 10A |
| Climatic class                       | SN/T                          |
| Noise level (dB)                     | 41                            |
| Refrigerant (gas)                    | R600a                         |
| Water connection / female attachment | female 3/4"                   |

### EFFICIENCY

|                               |     |
|-------------------------------|-----|
| New Energy Label class        | E   |
| Energy consumption (kWh/year) | 271 |

### DIMENSIONS & WEIGHT

|   |      |
|---|------|
| Height of the product (closed weels) (mm) | 2120 |
| Adjustable feet height (mm)               | 25   |
| Width of the product (mm)                 | 608  |
| Depth of Product without handle (mm)      | 620  |
| Wall cavity height (mm)                   | 2134 |
| Wall cavity width (mm)                    | 610  |
| Wall cavity depth (mm)                    | 630  |
| Net Weight (kg)                           | 151  |
| Gross Weight (kg)                         | 171  |

### TEMPERATURE RANGES

|   |                 |
|---|-----------------|
| Climatic compartments                   | 1               |
| Compartment 1 / Upper temperature (°C)  | from -15 to -22 |
| Compartment 2 / Middle temperature (°C) |                 |
| Low temp zone                           | NO              |
| Compartment 3 / Low temperature (°C)    |                 |
| Dual zone                               | NO              |

### ACCESSORIES

- Stainless steel sides panels
- 90° Door stop
- Ice maker with water filter
- Water filtration system
- Joining kit
- Stainless steel portal for freestanding
- Extra length anti-tipping kit
- Anti-condensation
- Cleaning kit
- Water filter cartridge
- FLD - Fhiaba Link Device
- Front ventilation kit
- Painting

# RS600FZ61

60 cm, FREEZER, 0FZ Model

BUILT-IN

DESIGNER® SERIE

## PRODUCT SPECIFICATIONS AND DIMENSIONS

*Fhiaba*

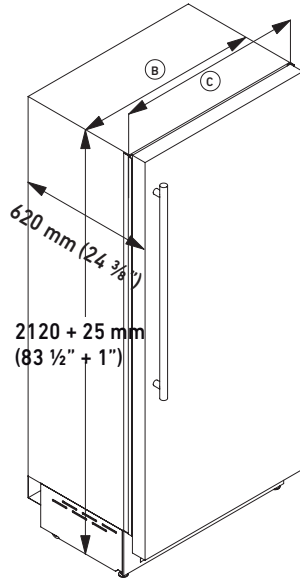
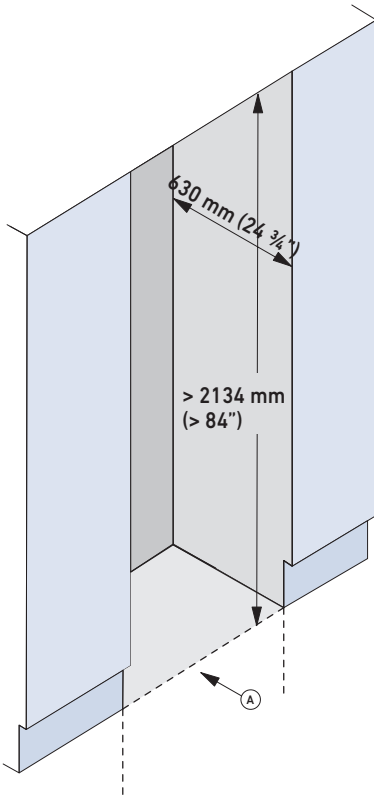

FRONT VIEW

SIDE VIEW

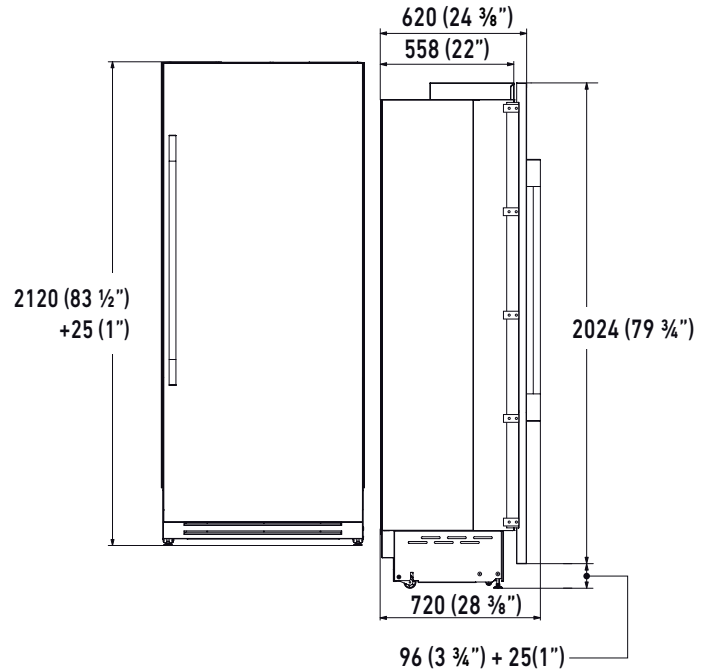

| TECHNICAL DATA                               |     |
|--|-----|
| Niche Width <b>A</b> (mm)                    | 610 |
| Unit Width <b>B</b> (mm)                     | 585 |
| Unit Width with lateral frames <b>C</b> (mm) | 608 |

TOP VIEW,  
HINGE 105°

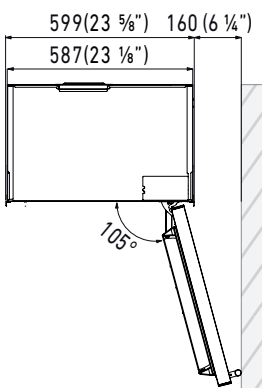

TOP VIEW,  
HINGE 90°

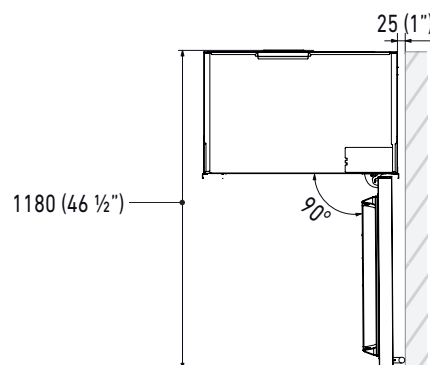

PLINTH SIZE

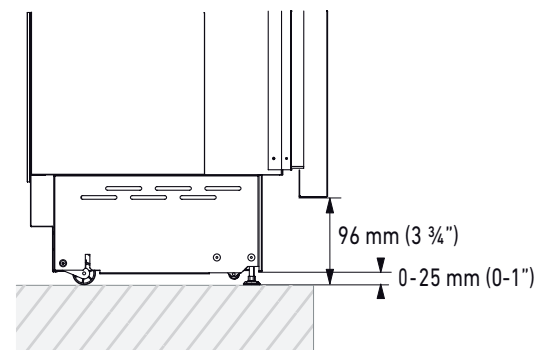

**i** For installation specifications, please consult with Fhiaba. For optimum installation, we recommend using the actual product as the best guide.

**i** Based on the adjustment of the feet and the height of the panel from the floor, the customer defines the perforated plinth to be installed on the equipment.

# RS600FZ6I

60 cm, FREEZER, 0FZ Model

BUILT-IN

DESIGNER® SERIE

## PRODUCT SPECIFICATIONS

*Fhiaba*

### Electrical Connection



Electrical and water connections (if applicable) should be reachable without having to uninstall the appliance. If the connections must be made directly behind the appliance then it is recommended to recess those connections.

**IMPORTANT:** do not put the water shut-off valve behind the appliance where it will be inaccessible.



For installation specifications, please consult with Fhiaba. For optimum installation, we recommend using the actual product as the best guide.



[www.fhiaba.com](http://www.fhiaba.com)