

Dear Customer,

Thank you for choosing a Smeg product.

By choosing Smeg, you have selected an appliance which combines iconic style with innovative technical design and attention to detail.

This appliance coordinates perfectly with other Smeg products, or works equally great as a standalone statement piece in your kitchen.

We hope you enjoy using your new appliance!

For any further information please visit www.smeg.com or www.smegusa.com (website valid only for the USA, Canada and South America).

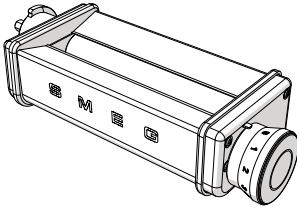

SMPR01
Pasta roller accessory

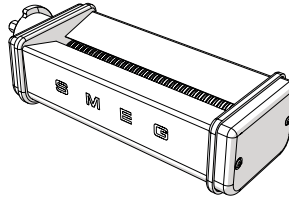

SMSC01
Spaghetti accessory

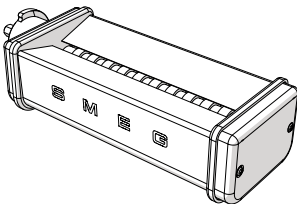

SMFC01
Fettuccine accessory

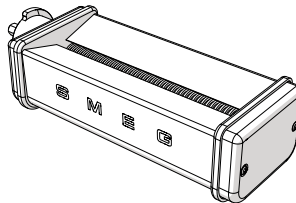

SMTC01
Tagliolini accessory

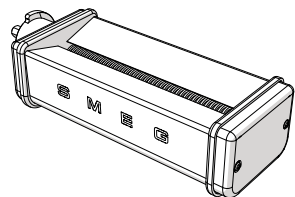
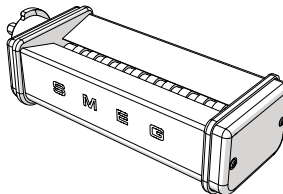
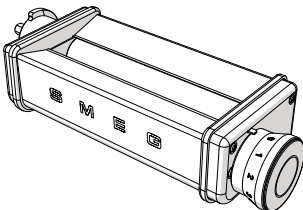

SMPC01
Pasta roller accessory and Pasta cutting set (Fettuccine and Tagliolini)

The manufacturer reserves the right to make any changes deemed useful for the improvement of its products without prior notice. The illustrations and descriptions contained in this manual are therefore not binding and are merely indicative.

Contents

1	Instructions	27
1.1	Introduction	27
1.2	This user manual	27
1.3	Intended use	27
1.4	Manufacturer liability	28
1.5	Disposal	28
2	Description	29
2.1	Product description	29
2.2	Standard accessories	30
3	Use	31
3.1	Before first use	31
3.2	Attaching the pasta roller and accessories for cutting the pasta	31
3.3	Using the pasta roller	33
3.4	Using the accessories for long pasta	35
4	Cleaning and Care	36
4.1	Instructions	36
4.2	Maintenance	36
4.3	Cleaning the surfaces	36
4.4	Ordinary daily cleaning	36
4.5	Food stains or residues	36
4.6	Lubricating the mechanism	36
4.7	Special maintenance	37
5	Recipes	38

Important Safeguards

WARNING: If the instructions contained in this manual are not followed precisely, fire or explosion may result causing property damage, personal injury or death.



READ AND SAVE THESE INSTRUCTIONS - Your safety and the safety of others are very important.

We have provided many important safety messages throughout this manual and on the appliance.

Read all the instructions before using the appliance and always obey all safety messages.



Important Safeguards



RECOGNIZE SAFETY INFORMATION

This is a safety alert symbol. This symbol alerts you to potential hazards that can result in severe personal injury or death.

UNDERSTAND SIGNAL WORDS

A signal word - DANGER, WARNING or CAUTION - is used with the safety alert symbol. DANGER denotes the most serious hazards. It means you could be killed or seriously injured if you do not immediately follow the instructions. WARNING means you could be killed or seriously injured if the instructions are not followed. CAUTION indicates a potentially hazardous situation, which, if not avoided, could result in minor to moderate injury.

WARNING



- This appliance is intended for use in the home only.
- Use this appliance only for its intended purpose. The manufacturer cannot be held liable for damage caused by improper use of this appliance.
- This appliance complies with current safety regulations. Improper use of this appliance can result in personal injury and material damage.
- Read all the instructions before installing or using the appliance for the first time.
- Keep these operating instructions in a safe place and pass them on to any future user.

The safety messages will inform you of potential hazards, on how to avoid the risk of injury and what can occur if the instructions are not followed.

IMPORTANT: Observe all codes and ordinances in force.

WARNING: For your safety, the instructions contained in this manual must be followed to minimize the risk of fire or explosion and to prevent property damage, personal injury or death.

Do not store or use gasoline or other flammable vapors, liquids or materials near this or any other appliance.



NOTE: This appliance is NOT designed for installation in manufactured (mobile) homes or in recreational vehicles (RVs).

DO NOT install this appliance outdoors.

Important Safeguards



WARNING



To reduce the risk of fire, electrical shock, personal injury, or damage when using the appliance, follow basic safety precautions, including the following:

Follow all safety instructions in order to use the appliance safely.

- Read this user manual and the manual supplied with the stand mixer carefully before using the appliance.
- To protect against electric shock, do not immerse the appliance, the power cord or the plug in water or any other liquid.
- Do not use the stand mixer when the power cord or the plug is damaged or after the appliance malfunctions, or when the appliance has fallen or is damaged in any manner. Return appliance to the nearest authorized service center for examination, repair or adjustment.
- Do not use the accessories if the stand mixer power cord or the plug is damaged, or if the stand mixer has been dropped or is damaged in any manner.
- If the power cord is damaged, it must be replaced by the manufacturer, its service agent or similarly qualified persons in order to avoid a hazard.
- The cable is short to prevent accidents. Do not use an extension cord.
- Do not let cord hang over edge of table or counter or touch hot surfaces.
- Do not place the appliance above or near lit gas or electric burners, inside an oven or near other heat sources.
- Switch off the appliance immediately after use.
- Do not leave the appliance unattended while it is operating.
- Do not use the accessories if they are damaged.
- Do not leave the accessories unattended during use.
- Do not modify the accessories.
- Do not try to repair the accessories yourself or without the assistance of a qualified technician.
- Turn the appliance OFF, then unplug from the outlet when not in use, before assembling or disassembling parts and before cleaning. To unplug, grasp the plug and pull from the outlet. Never pull from the power cord.
- In case of fault, repairs should only be carried out by a qualified technician.
- Never try to put out a fire or flames with water: turn off the appliance, remove the plug from the socket and smother the flames with a fire blanket or any other appropriate cover.
- Do not modify the appliance.
- Keep the appliance out of children's reach.



Important Safeguards

For the appliance and accessories

- Unplug the appliance from the power socket as soon as you have finished using it and before cleaning it.
- Always unplug the appliance from the wall if it is left unattended and before assembling, disassembling or cleaning.
- Remove beaters from mixer before washing.
- Do not insert, remove or replace attachments with the safety lock disengaged (motor head lowered).
- Do not touch moving parts while the appliance is operating. Keep hands, hair, clothing, spatulas and any other objects away from the mixer's attachments and accessories to avoid personal injury or damage to the appliance.
- Do not remove attachments while the mixer is operating. Switch off the appliance and unplug it before changing accessories or approaching moving parts while they are in use.
- Check that the bowl is correctly positioned and locked into its base before using the appliance with its attachments.
- Do not release or remove the bowl while the appliance is operating.
- Do not exceed the bowl's maximum capacity.
- Let the appliance cool down before cleaning.
- The use of attachments not recommended or sold by the manufacturer may cause fire, electric shock or injury.
- Do not place objects on top of the appliance.
- Do not use harsh detergents or sharp objects to wash or remove residues from the bowl, attachments or accessories.
- Do not use outdoors.
- The stand mixer can be used to mix, whip, whisk and knead solid and liquid ingredients to speed up the preparation time for various recipes. With the addition of optional accessories it is able to grind, mince, grate, mill, roll out and cut pasta into different shapes, etc.
- Close supervision is necessary when any appliance is used by or near children.
- Do not use more than one attachment at a time.
- Turn off the stand mixer before attaching or removing the accessories.
- Do not remove accessories while the stand mixer is operating. Check that the speed selector is in the 0 (OFF) position.
- Let the accessories cool down before cleaning.
- Do not use harsh detergents or sharp scrapers to clean the accessories.
- Do not place objects on top of the accessories.

SAVE THESE INSTRUCTIONS

Important Safeguards



1 Instructions

1.1 Introduction

Key information for the user:

Instructions



General information on this user manual, on safety and final disposal.

Description



Description of the accessories.

Use



Information on using the accessories.

Cleaning and care



Information on proper cleaning and maintenance of the accessories.

Recipes



List of recipes for preparing various types of pasta.



Safety instructions



Information



Advice

1.2 This user manual

This user manual is an integral part of the appliance and must therefore be kept in its entirety and within the user's reach for the whole working life of the appliance.

1.3 Intended use

- These accessories are designed exclusively for home use.
- Use these accessories only in combination with the same manufacturer's stand mixer.
- Use the accessories indoors.
- The pasta roller can be used to roll out the pasta to the required thickness.
- The long pasta accessories can be used to cut the pasta into different shapes (tagliatelle, tagliolini, fettuccine and spaghetti).
- Do not use the accessories for anything other than their intended use.
- These accessories may not be used by people (including children) of reduced physical or mental capacity, or lacking in experience in the use of electrical appliances, unless they are supervised or instructed by adults who are responsible for their safety.



The California Safe Drinking Water and Toxic Enforcement Act requires the Governor of California to publish a list of substances known to the State of California to cause cancer, birth defects or other reproductive harm, and requires businesses to warn customers of potential exposure to such substances.



Important Safeguards



Warning

- This product contains a chemical known by the State of California to cause cancer, birth defects or other reproductive harm.
- This appliance can cause low-level exposure to some of the substances listed, including benzene, formaldehyde, carbon monoxide, toluene, and soot.

1.4 Manufacturer liability

The manufacturer shall not be held responsible for personal injuries or property damage caused by:

- Using the accessories for purposes other than those intended;
- Not having read the user manual;
- Tampering with any part of the accessories;
- Using non-original spare parts
- Not following the safety instructions.

1.5 Disposal



Power voltage
Danger of electrocution

- Turn off the appliance.
- Unplug the appliance from the wall outlet.
- **Old appliances do not belong in household waste!** To comply with current legislation, old appliances, having reached the end of their useful lives, should be taken to a disposal facility where they can be sorted. In this way, any valuable material contained in the old appliances can be recycled and the environment protected. Local authorities or their waste disposal operators can provide further information.

Our accessories are packed in non-polluting and recyclable materials.

- Dispose of the packing materials at an appropriate disposal facility.



Plastic packaging
Danger of suffocation

- Do not leave the packaging or any part of it unattended.
- Do not let children play with the plastic bags.



2 Description

2.1 Product description

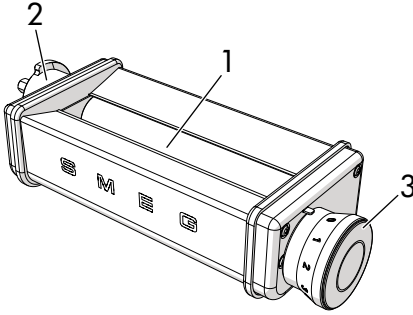

SMPR01 - Pasta roller accessory

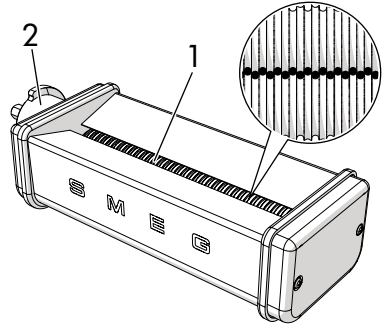

SMSC01 - Spaghetti accessory

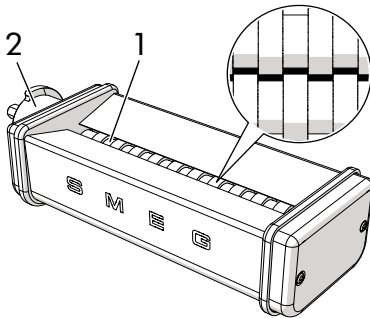

SMFC01 - Fettuccine accessory

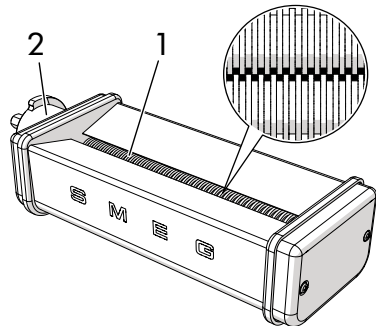

SMTC01 - Tagliolini accessory

1 Rollers

2 Attachment

3 Thickness selection knob



Description

2.2 Standard accessories

Brush

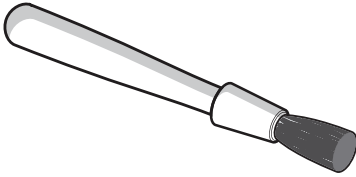

For removing dry pasta residue from the accessories and rollers.



The accessories intended to come into contact with food are made of materials that comply with the provisions of current legislation.



3 Use



Electrical Shock Hazard

- Plug into a grounded 3-prong outlet.
- Do not remove the ground prong.
- Do not use an adapter.
- Do not use an extension cord.
- Failure to follow these instructions can result in death, fire, or electrical shock.

Volts: 120 Volts AC only.

Hertz: 60 Hz



Your stand mixer has a 3-prong grounded plug. To reduce the risk of electrical shock, this plug will fit into an outlet only one way. If the plug does not fit in the outlet, contact a qualified electrician. Do not modify the plug in any way.

- Do not use an extension cord. If the power supply cord is too short, have a qualified electrician or service technician install an outlet near the appliance.
- A short power supply cord (or detachable power supply cord) should be used to reduce the risk resulting from becoming entangled in or tripping over a longer cord.
- Longer detachable power supply cords or extension cords are available and may be used if care is taken when using them.

If a longer detachable power supply cord or extension cord is used:

- The marked electrical rating of the power supply cord or extension cord should be at least as great as the electrical rating of the appliance.
- The cord should be arranged so that it will not hang over the countertop or tabletop where it can be pulled on by children or tripped over unintentionally.
- If the appliance is of the grounded type, the extension cord should be a grounded, 3-prong cord.

3.1 Before first use

1. Remove any protective packaging from the outside or inside of the accessories.
2. Remove any labels from the accessories.
3. Clean the accessories (see "4 Cleaning and Care").
4. Prepare the pasta to be rolled with the pasta roller or to be cut with the accessories for long pasta.

3.2 Attaching the pasta roller and accessories for cutting the pasta

1. Turn off the stand mixer by moving the mixer lever (1) to the '0' (OFF) position.

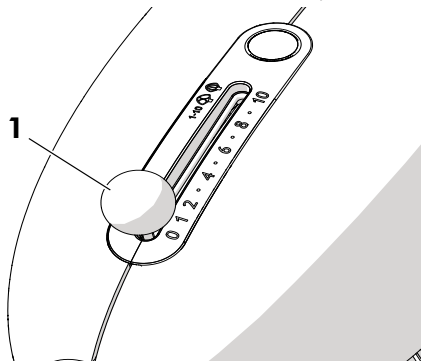

2. Remove the plug from the power socket.



Use

3. Press the release button (2).
4. Hold down the button and raise the head (3), accompanying its movement with your hand.
5. Remove any standard accessories (dough hook, wire whisk, flat beater) which may be inserted in the mixer.

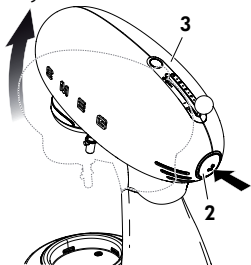

6. Grasp the front attachment hub cover (4) at the center and turn it clockwise.

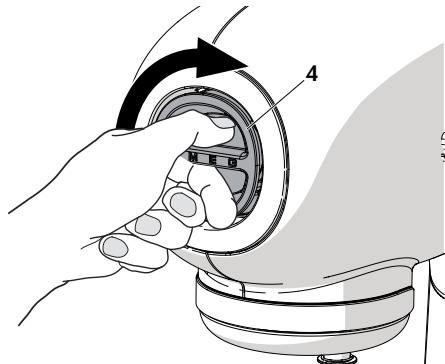

7. Pull the cover (4) to remove it.

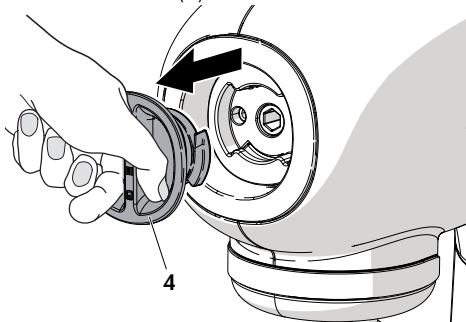

8. Insert the accessory (5) following the guide in the attachment hub (6), then turn it 60°.

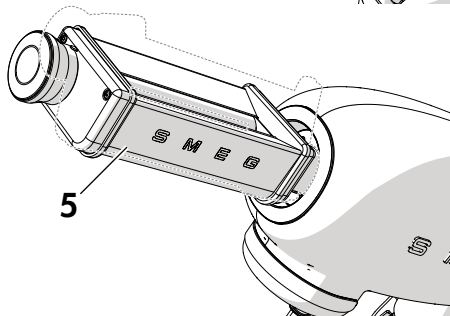
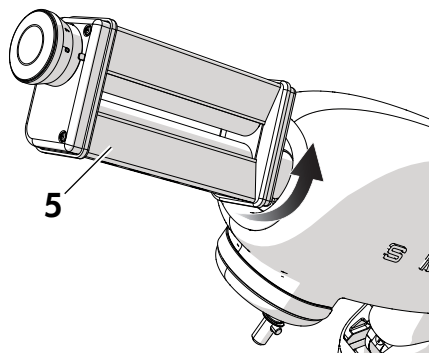
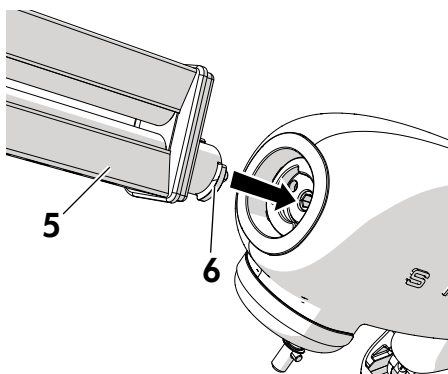

9. Press the release button and lower the stand mixer head, supporting it with your hand as you lower it.



3.3 Using the pasta roller

Pasta roller settings

Setting	Suitable for
2	Kneading, rolling out
3	Thick egg pasta
4	Egg pasta
4 or 5	Pasta for lasagne, fettuccine, spaghetti, tagliolini
6 or 7	Pasta for tortellini, thin fettuccine
7 or 8	Very thin pasta

1. Follow the tips given in the section “Tips for perfect pasta dough” when preparing the pasta dough.

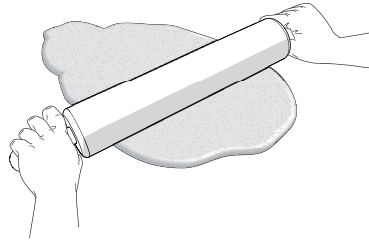

2. Cut the pasta dough into pieces approximately 1 cm (1/2 inch) thick.
3. Pull the knob (7) in the direction shown by the arrow A to release it, then turn it to the ‘1’ position.

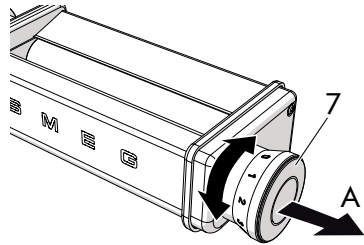

4. Let go of the knob (7) and ensure that it has locked into position.

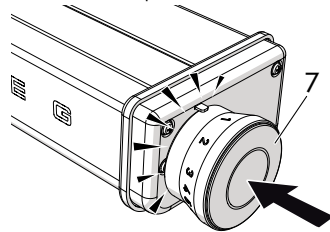

5. Plug the stand mixer into the power socket.



Risk of food poisoning

- Do not leave ingredients subject to spoiling such as eggs, dairy, etc. outside the fridge for more than one hour.



Use

6. Move the stand mixer speed selector lever (9) to the '1' position to start the rollers.

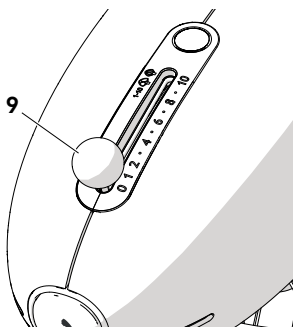

8. Fold the dough in two and insert it between the rollers again.
9. Select position '2' with the knob on the pasta roller. Pass the dough between the rollers to roll it thinner. Continue to gradually reduce the space between the rollers, until you obtain pasta of the required thickness. (See "Pasta roller settings" for further details).
10. Move the stand mixer speed selector to the '0' (OFF) position to stop it.



Improper use
Risk of damage to the accessory

- Do not use the pasta roller to roll out or cut any kind of dough other than pasta dough.

11. Once you have finished using the accessory, unplug the mixer, remove the accessory from the attachment hub and replace the cover on the attachment hub.



Moving parts
Danger of personal injury and damage to the appliance

- Do not touch the accessories while the appliance is running.
- Do not use the accessories for anything other than the uses specified.

7. Sprinkle flour on both sides of a piece of dough. Then pass it through the rollers to roll it out.

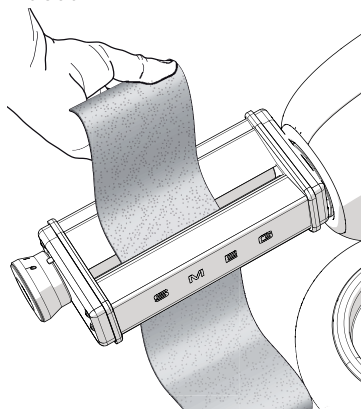



3.4 Using the accessories for long pasta

Use the pasta roller to roll out the dough to the thickness required for the type of pasta you wish to cut, as described in section “3.3 Using the pasta roller”.

1. Select the required long pasta accessory.
2. Follow the same procedure described in section “3.2 Attaching the pasta roller and accessories for cutting the pasta” to attach the accessories for long pasta.
3. Pass the dough through the chosen pasta cutting accessory (1) in order to shape it into the required type of pasta.

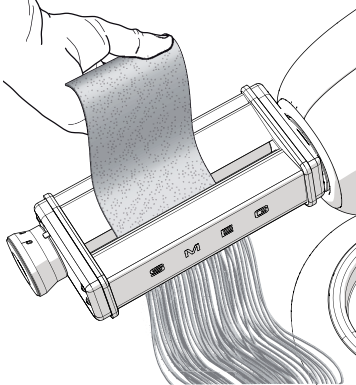

Moving parts
Danger of personal injury and damage to the appliance

- Do not touch the accessories while the appliance is running.
- Do not use the accessories for anything other than the uses specified.

4. Move the stand mixer speed selector to the '0' (OFF) position to stop it.

Tips for perfect pasta dough

- Humidity, type of flour chosen and size of the eggs used can all influence the consistency of the pasta dough.
- The pasta dough should be firm and rough to the touch, but should also be malleable. It should not stick to your fingers or crumble.
- Pinch the pasta dough to check its consistency. If the dough remains compact and does not stick to your fingers, it is suitable. If this is not the case, add a little flour. If the pasta is crumbly, add a little water.
- Cut the sheets of pasta into two or more pieces before cutting them into fettuccine, tagliolini or spaghetti, as they will be difficult to manage if they are too long.
- The pasta may be cooked immediately after cutting.

Tips for preserving pasta

Freshly made pasta may be eaten immediately, or dried or frozen to be used at a later date.

- To dry the pasta, spread it out in a single layer on a tray or dish towel for approximately one hour and leave it to air dry. The dried pasta can be kept in an airtight plastic container.
- To freeze the pasta, let it dry in the air for approximately one hour, sprinkle it with flour and roll it up into nests. Then place it in an airtight plastic container and store it in the freezer.



Cleaning and Care

4 Cleaning and Care

4.1 Instructions



Improper use
Danger of electrocution

- Switch off and unplug the mixer before cleaning it and its attachments and accessories.



Improper use
Risk of damage to surfaces

- Do not place the accessories in water.
- Never wash in the dishwasher.
- Do not use steam jets to clean the accessories.
- Do not use cleaning products containing chlorine, ammonia or bleach.
- Do not use abrasive or corrosive detergents (e.g. powder products, stain removers and metallic sponges).
- Do not use rough or abrasive materials or sharp metal scrapers.

4.2 Maintenance

All service should be performed by an authorized service representative.

4.3 Cleaning the surfaces

To keep the surfaces in good condition, they should be cleaned regularly after use.

4.4 Ordinary daily cleaning

Use a soft cloth or a dry microfiber cloth to clean the surfaces.

4.5 Food stains or residues

Let the pasta roller and the long pasta accessories dry for at least one hour before removing any pasta residue. Use the supplied brush to remove any dry pasta residue.

Never use sharp scrapers or knives, as these will damage the surface.

Do not insert cloths or dish towels between the rollers to clean them.

4.6 Lubricating the mechanism

Lubricate the mechanism at least once a year, or every 50 uses.

Use a light mineral oil.

1. Apply a drop of mineral oil to each of the four corners of the rollers.

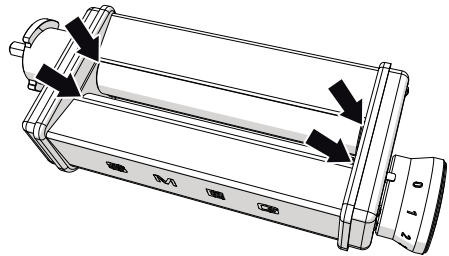



4.7 Special maintenance

For more thorough cleaning and to avoid the proliferation of germs which could contaminate the pasta, disassemble the scrapers and clean the rollers of the long pasta accessories as follows:

1. Remove the lower scrapers (1) by pressing down on the milled parts (2) and moving the scraper sideways.

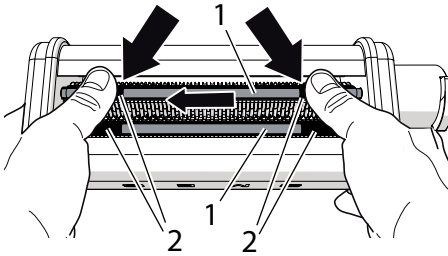

2. Insert the end (3) of the rod in the hole (4) of the scraper (5) and pull upwards.

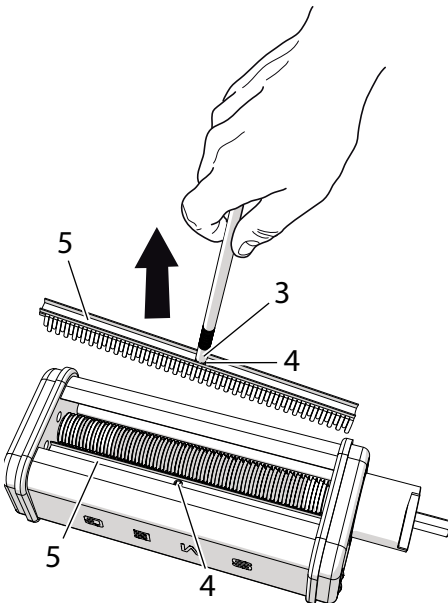

3. Clean the pasta roller and the long pasta accessories using the supplied brush (6).

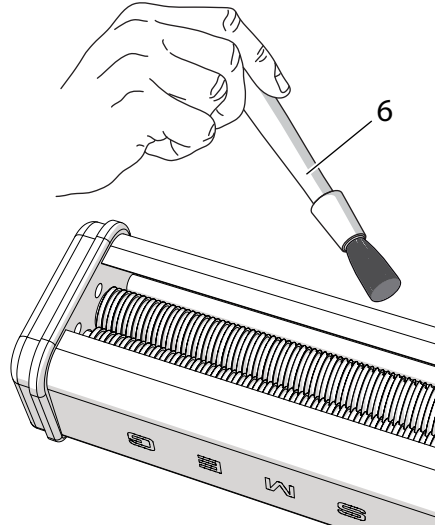

4. Put the scrapers back in place, following the above procedure in reverse.



Important

- Before cleaning, let the pasta cutting accessories dry for at least one hour, then remove any dry pasta residue with the cleaning brush. If this is difficult, tap the accessory with your hand.



Recipes

5 Recipes

Whole Wheat Fettuccine



Ingredients:

- 270g (2 1/4 cups) whole wheat flour
- 130g (3/4 cup) Durum wheat semolina
- 4 eggs
- 2-3 tablespoons water (if required)
- A pinch of salt
- Flour to roll the dough

Method

1. Using the dough hook attachment, mix the flour, semolina, salt and eggs on speed 1 or 2 for 3-5 minutes. Soften the dough with water if necessary.
2. Remove the dough from the bowl, wrap with cling film and let rest in the refrigerator for 30 minutes.
3. Roll the dough using the pasta roller accessory, sprinkling with flour when necessary so that it does not stick. Pass it through the roller several times, reducing the thickness from no. 0 to 5.
4. Allow the sheets of pasta to dry a little, and then make the fettuccine using the fettuccine accessory.
5. Sprinkle the fettuccine strips with flour, form into nests and let dry well.

Lasagna Sheets



Ingredients:

- 400g (3 1/4 cups) flour
- 4 eggs
- 20g (1 1/2 tablespoons) water
- A pinch of salt
- Flour to roll the dough

Method

1. Using the dough hook attachment, mix the flour, salt and eggs on speed 1 or 2 for 3-5 minutes. Soften the dough with water if necessary.
2. Remove the dough from the bowl, wrap with cling film and let rest in the refrigerator for 30 minutes.
3. Roll the dough using the pasta roller accessory, sprinkling with flour when necessary so that it does not stick. Pass it through the roller several times, reducing the thickness from no. 0 to 3.
4. When the dough is at thickness 3, change to thickness 6 and roll through once. Cut it into ready-to-use rectangles.



Spinach Tagliolini



Ingredients:

340g (2 3/4 cup) flour

3 eggs

70g (2 1/2 oz) spinach (cooked, squeezed and blended)

A pinch of salt

Flour to roll the dough

Method

1. Using the dough hook attachment, mix the flour, salt, eggs and spinach on speed 1 or 2 for 3-5 minutes.
2. Remove the dough from the bowl, wrap with cling film and let rest in the refrigerator for 30 minutes.
3. Roll the dough using the pasta roller accessory, sprinkling with flour when necessary so that it does not stick. Pass it through the roller several times, reducing the thickness from no. 0 to 5.
4. Leave the dough to rest for a few minutes, then cut with the tagliolini accessory, sprinkling the pasta with flour.
5. Sprinkle the tagliolini strips with flour, form into nests and let dry thoroughly.

Tomato cannelloni sheets



Ingredients:

300g (2 1/2 cups) flour

2 eggs

1 egg yolk

120g (4 1/4 oz) of concentrated tomato purée

1-2 tablespoons water (if required)

A pinch of salt

Flour to roll the dough

Method

1. Pour the flour and salt in the mixer bowl. In a separate bowl beat the whole eggs with the egg yolk and the concentrated tomato puree and pour into the flour. Using the dough hook attachment, mix everything together on speed 1 or 2 for 3-5 minutes. If necessary, soften with water.
2. Remove the dough from the bowl, wrap with cling film and let rest in the refrigerator for 30 minutes.
3. Roll the dough using the pasta roller accessory, sprinkling with flour when necessary so that it does not stick. Pass it through the roller several times, reducing the thickness from no. 0 to 5.
4. Roll through one last time at thickness 6.
5. Cut the dough into ready-to-use rectangles of about 10 x 12 cm (3.9 x 4.7 inches).



Spaghetti

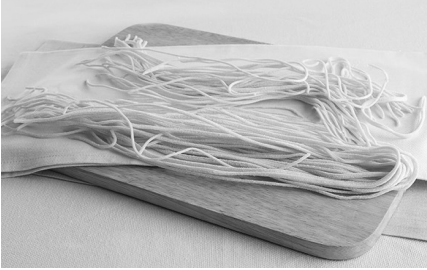

Ingredients:

400g (2 1/2 cups) Durum wheat semolina

230g (1 cup) hot water

6g (1 teaspoon) salt

Flour to roll the dough

Method

1. Using the dough hook attachment, mix the semolina, water and salt on speed 1.
2. Work it for 4 or 5 minutes to make a smooth dough.
3. Remove the dough from the bowl, wrap with cling film and let rest in the refrigerator for 30 minutes.
4. Roll the dough using the pasta roller accessory, sprinkling with flour when necessary so that it does not stick. Pass it through the roller several times, reducing the thickness from no. 0 to 1.
5. Let the pasta rest for 10-15 minutes, then cut with the spaghetti accessory, sprinkling the pasta thoroughly with flour.
6. Allow to dry before use.