

SOU330X1



Category	30"
Product family	Oven
Power supply	Electrical
Power supply	Electricity
Cooking method	Thermo-ventilated
Cleaning system	Self-cleaning
EAN code	8017709204501



Aesthetic

Aesthetics	Classic	Silkscreen type	Symbols and wordings
Color	Stainless steel	Door	With 2 horizontal fascias
Finishing	Fingerprint-proof	Handle	Classic
Design	Flat	Handle color	Stainless steel
Material	Stainless steel	Logo	Embossed
Stainless steel type	Brushed	Control knobs	Classic
Glass type	Eclipse	Controls color	Stainless steel effect
Silkscreen color	Black		

Controls

Controls setting	Knobs / buttons	No. of controls	2
------------------	-----------------	-----------------	---

Programs / Functions

No. of cooking functions 11

Traditional cooking functions



Static



True European convection



Turbo



Large grill



Circulaire + grill



Pizza

Other functions



Defrost by time



Defrost by weight



Proof



Sabbath



Dehydrate

Cleaning functions



Self-cleaning cycle

Options



Time-setting options

Delayed start and automatic shut-off when cooking ends

Minute minder

Yes

Child safety lock

Yes

Other options

Rapid pre-heating

Keep-warm

Yes

Technical Features



Minimum Temperature	86 °F
Maximum temperature	554 °F
No. of shelves	6
Fan	Double fan
No. of lights	3
Lighting	Halogen
Light power	20 W
Light on when door is open	Yes
Lower heating element power	3000 W
Upper heating element - Power	1032 W
Large grill - Power	3500 W

Circular heating element - Power	1300 W
Circular heating element 2 - Power	1300 W
Heating elements stop when door is opened	Yes
Removable door	Yes
Total no. of door glasses	4
Cooling system	Tangential
Door lock during self-cleaning cycle	Yes
Inner cavity dimensions (HxWxD)	410x610x415; mm
Temperature control	Electronic
Cavity material	Enamel

Performance / Energy Label



Volume of the cavity 3.64 cu. ft.

Number of cavities 1

Accessories Included



Rack with back and side stop 2

Enameled 0.8"-deep tray 1

Insert grid 1

Telescopic Guide rails, total Extraction 1

Temperature probe Yes, single-point probe

Electrical Connection

Voltage 120/240 V
 Current 16.9 A
 Nominal power 3535 W
 Voltage 120/208 V

Current 17.5 A
 Frequency 60 Hz
 Power cord length 78 3/4 "

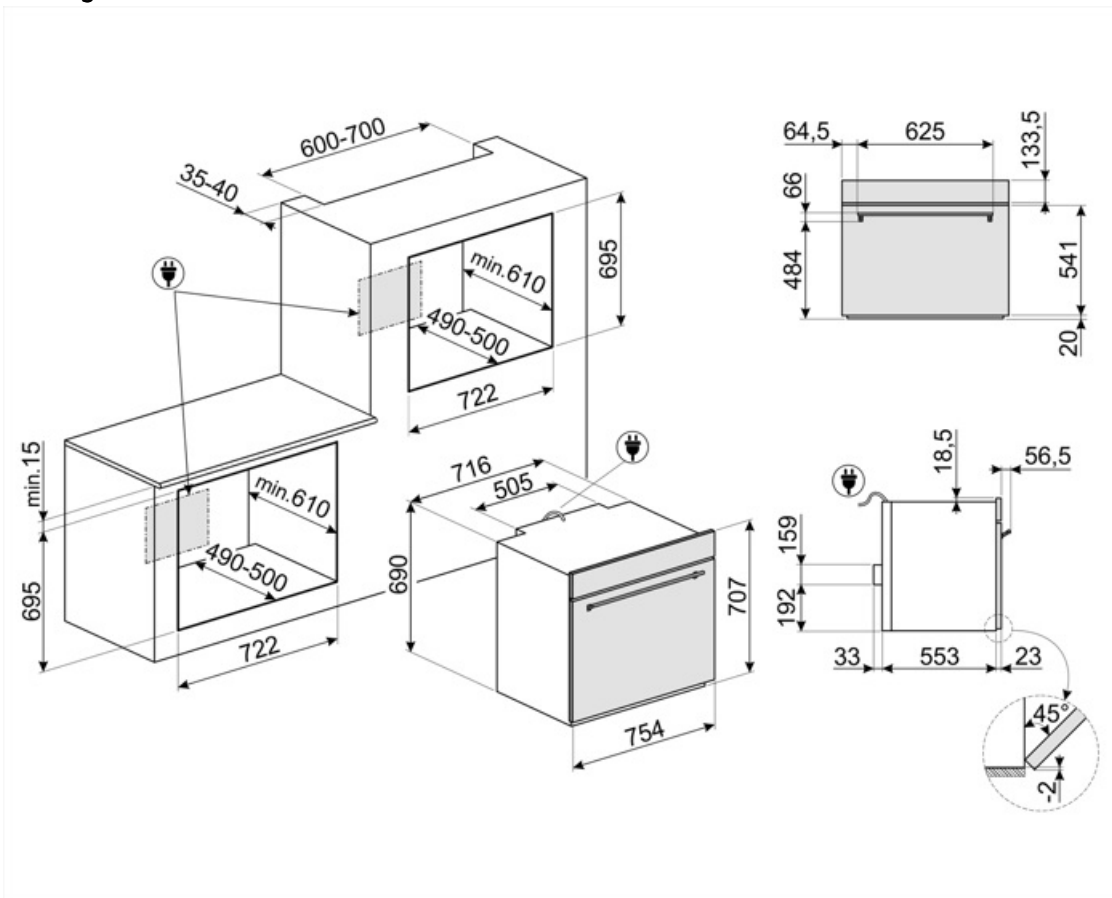





















Not included accessories

STONE

Rectangular refractory stone PPR2. Ideal for cooking pizzas with the same results as a typical wood-fired oven. Can also be used for baking bread, focaccias and other recipes such as pies, flans or biscuits Dimensions: L42 x H1,8 x P37,5 cm.



Symbols glossary (TT)

 <p>Child lock: some models are fitted with a device to lock the programme/cycle so it cannot be accidentally changed.</p>	 <p>Air cooling system: to ensure a safe surface temperatures.</p>
 <p>Defrost by time: with this function the time of thawing of foods are determined automatically.</p>	 <p>Defrost by weight: With this function the defrosting time is determined</p>
 <p>Quadruple glazed: Number of glazed doors.</p>	 <p>Electric</p>
 <p>Upper and lower element only: a traditional cooking method best suited for single items located in the centre of the oven. the top pf the oven will always be hottest. Ideal for roast, fruit cakes, bread etc.</p>	 <p>Circulaire + grill: Circulaire with upper element or grill: Similar to fan with upper element with the added cooking speed of circulaire, ideal for dishes with a crispy topping. When used with the grill the food will brown more quickly.</p>
 <p>True European Convection: The combination of the fan and circular heating element around it provides many benefits, including no preheat if cooking time is longer than 20 minutes, no flavor transfer when cooking different foods at the same time, lower energy consumption, and shorter cooking times. Suitable for all types of food preparations.</p>	 <p>Grill element: Using of grill gives excellent results when cooking meat of medium and small portions, especially when combined with a rotisserie (where possible). Also ideal for cooking sausages and bacon.</p>
 <p>Pizza function: The simultaneous operation of three elements ensures an optimum cooking facility when used with the Smeg pizza stone.</p>	 <p>Circulaire with upper and lower elements: The use of the fan with both elements allows food to be cooked quickly and effectively, ideal for large joints that require thorough cooking. It offers a similar result to rotisserie, moving the heat around the food, instead of moving the food itself, enabling any size or shape to be cooked.</p>
 <p>KEEP_WARM_72dpi</p>	 <p>Side lights: Two opposing side lights increase visibility inside the oven.</p>
 <p>Pyrolytic: Pyrolytic cleaning cycles can be selected as necessary to automatically clean the oven interior.</p>	 <p>Cooking with temperature probe: It is possible to display the temperature detected by the probe and set a target temperature that the dish must reach. When the core of the dish reaches the desired temperature, cooking stops</p>
 <p>Air at 40°C provides the perfect environment for proving yeast type dough mixes. Simply select the function and place dough in the cavity for allotted</p>	 <p>Rapid preheat: The rapid preheat function can be used to reach the selected temperature in just a few minutes.</p>
 <p>Sabbath: This function allows you to cook food during the Sabbath, the Holiday of rest in the Jewish religion, respecting the precepts. The oven works</p>	 <p>The oven cavity has 6 different cooking levels.</p>



Telescopic rails: allow you to pull out the dish and check it without having to remove it from the oven entirely.



Electronic control: Allows you to maintain temperature inside the oven with the precision 2-3 ° C. This enables to cook meals that are very sensitive to temperature changes, such as cakes, souffles, puddings.



The capacity indicates the amount of usable space in the oven cavity in litres.



...