

SPR24UGGX

Range size 24"
Main oven Gas with grill
Cleaning system - Main oven VaporClean
EAN code 8017709301446



Aesthetic



Series Professional
Color Stainless steel
Finishing Satin
Front panel color Stainless steel
Cooktop color Black enamel
Grates Cast Iron

Control setting type Control knobs
Control knobs Pro-style control knobs
No. of controls 6
Handle Robust knurled handle
Handle color Brushed stainless steel
Storage compartment Storage drawer

Programs / Functions

No. of cooking functions 3
Traditional cooking functions



Large grill



Bottom



Convection bottom

Other functions



Defrost by time

Cooktop technical features

Cooking zones 4
 Front-left - 3500 W - 12000 BTU
 Rear-left - 2900 W - 10000 BTU
 Rear-right - 2900 W - 10000 BTU

Front-right - 5300 W - 18000 BTU

Automatic gas ignition Yes
Gas safety valves Yes

Burner caps Enameled matte black

Main Oven Technical Features



No. of lights 1
Fan number 1
Volume 2.79 cu. ft.
Cavity material EverClean enamel
No. of shelves 5
Light type Halogen
Light Power 40 W

Removable door Yes
Removable inner door Yes
Total no. of door glasses 3
Cooling system Tangential
Grill type Gas
Soft Close system Yes

Main oven options

Minimum Temperature 250 °F

Maximum temperature 500 °F

Accessories included for main oven and cooktop

Oven wire rack 2

Electrical Connection

Plug (B) NEMA 5-15P
Current 15 A
Circuit breaker 15 A
Voltage 120 V

Type of electric cable installed Yes, Single phase
Power cord length 47 1/4 "
Frequency 60 Hz

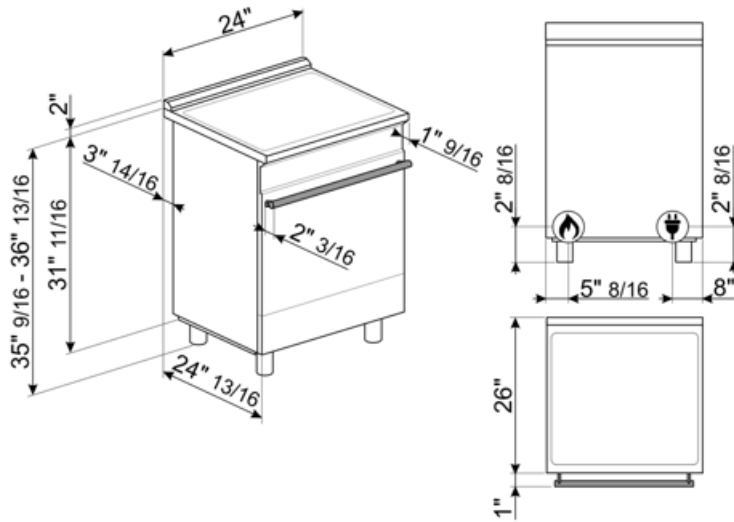

Not included accessories



GRM

Gas hobs moka support



KITTKSPR24

Plinth, 3 sides, 900mm , SPR cookers
24", black



PRTX

Refractory pizza stone with handles.
D=35cm Not suitable for microwave
ovens. Suitable for gas ovens, to be put
on the griddle.



WOKGHU

Cast-Iron WOK Support



GTP

**Partial-extension telescopic
guides** Length: 14" Extraction: 11
1/4" Material: Stainless steel AISI 430
polished



PALPZ

















Pizza shovel with fold away handle
width: 315mm length : 325mm



SFLK1

Child lock

Symbols glossary (TT)

	Heavy duty cast iron pan stands: for maximum stability and strength.		Installation in column: Installation in column
	Air cooling system: to ensure a safe surface temperatures.		Defrost by time: with this function the time of thawing of foods are determined automatically.
	Triple glazed doors: Number of glazed doors.		Enamel interior: The enamel interior of all Smeg ovens have a special antacid lining which helps keep the interior clean by reducing the amount of cooking grease adhering to it.
	Circogas: In gas ovens the fan distributes the heat quickly and evenly throughout the oven cavity, avoiding flavour transfer when cooking a number of different dishes at the same time. In electric ovens this combination completes cooking more quickly of foods that are ready on the surface, but that require more cooking inside, without further browning.		Lower heating element only: This function is ideal for foods that require extra base temperature without browning, e.g. pastry dishes, pizza. Also suitable for slow cooking of stews and casseroles.
	Grill element: Using of grill gives excellent results when cooking meat of medium and small portions, especially when combined with a rotisserie (where possible). Also ideal for cooking sausages and bacon.		Gas ovens offer instantaneous heat control, reduced cooking times and the ability to bake at much lower temperatures than electric ovens.
	The inner door glass: can be removed with a few quick movements for cleaning.		Side lights: Two opposing side lights increase visibility inside the oven.
	The oven cavity has 5 different cooking levels.		Soft close: all models are equipped with advanced function of smooth closing of the door, which allows the device to close smoothly and quietly.
	Vapor Clean: a simple cleaning function using steam to loosen deposits in the oven cavity.		Knobs control

Benefit (TT)

Gas hob

Induction offers fast cooking and precise temperature control

Equipped with a thermocouple, the gas supply is cut off if the flame is extinguished for greater safety

Vapor Clean

By inserting water into a recess at the bottom of the cavity, steam is generated, which softens the residue and facilitates its removal

By inserting water into a recess at the bottom of the cavity, steam is generated, which softens the residue and facilitates its removal.

Single turbine

The oven has a fan equipped with a circular heating element allowing cooking with rotating heat

Isothermic Cavity

The best cooking performance at the highest energy efficiency

Tangential cooling

New cooling system with tangential fan and airflow from the door to the splashback

Soft close

The door is equipped with a specific system for silent closing

Multilevel halogen light

Internal halogen lighting on different levels guarantees excellent visibility

Adjustable height

Cooker top flushed with the working area thanks to adjustable feet

Removable inner glass

Internal door glasses are easily removable for complete cleaning

Multilevel cooking

Several cooking levels allow maximum flexibility of use

Cold door

During any function, the external door glass is cold, avoiding any risk of burns

AirFry (AIRFRY optional accessory)

Lighter and tastier food thanks to airfry basket

BBQ (optional accessory)

Barbeque cooking directly in the oven with the double-sided grill

Pizza stone (optional accessory)

Baking with refractory stone for soft and crispy pizza and yeast products (STONE optional accessory)

Knobs control

Easy and intuitive timer setting with a elegant knobs

Storage compartment

More space thanks to the lower compartment, ideal for storing accessories or cooking utensils