

PROJECT NAME		LOCATION		AIA #
ITEM #	QTY	MODEL #		SIS #

SPEC SERIES®

ROLL-IN SOLID SWING DOOR REFRIGERATOR

models	STR2RRI89-2S-HC	STA2RRI89-2S-HC	STG2RRI89-2S-HC
--------	-----------------	-----------------	-----------------



STR2RRI89-2S-HC	
Exterior	Stainless steel door, front & sides.
Interior	Stainless steel side walls, back, floor, door liner, & ceiling.

STA2RRI89-2S-HC	
Exterior	Stainless steel door, front & sides.
Interior	Aluminum side walls & back. Stainless steel floor & ceiling.

STG2RRI89-2S-HC	
Exterior	Stainless steel door, with matching aluminum sides.
Interior	Aluminum side walls & back. Stainless steel floor & ceiling.

plan view

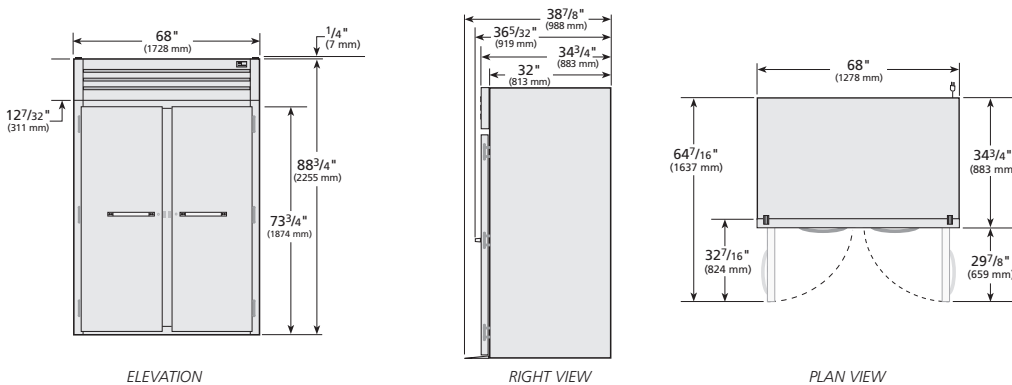

SPECIFICATIONS

Dimensions	in.	mm.
Length	68	1728
Depth	34 3/4	883
Height	88 3/4	2261
Electrical	U.S.	International
Horsepower	1/2	N/A
Amps	9.7	N/A
Voltage	115/60/1	
NEMA	5-15P	
Cord Length	9 ft.	2.74 M.

115/60/1 NEMA-5-15R
 † Depth does not include 4 1/4" (108 mm) for ramp.
 * Height does not include 1/4" (7 mm) for system mechanical components.

Specifications subject to change without notice.
 Chart dimensions are rounded up to the nearest 1/8" (millimeters rounded up to the next whole number).



PROJECT NAME	LOCATION	AIA #
ITEM #	QTY	MODEL #
		SIS #

SPEC SERIES®

ROLL-IN SOLID SWING DOOR REFRIGERATOR

models	STR2RRI89-2S-HC	STA2RRI89-2S-HC	STG2RRI89-2S-hC
--------	-----------------	-----------------	-----------------



standard features

REFRIGERATION SYSTEM

- Factory engineered, self-contained, expansion valve (TXV) system using environmentally friendly R290 hydrocarbon refrigerant that has zero (0) ozone depletion potential (ODP), & 0.02 global warming potential (GWP).
- High capacity, factory balanced refrigeration system that maintains cabinet temperatures of 33°F to 38°F (.5°C to 3.3°C) for the best in food preservation.
- State of the art, electronically commutated evaporator and condenser fan motors. ECM motors operate at higher peak efficiencies and move a more consistent volume of air which produces less heat, reduces energy consumption and provides greater motor reliability.
- Top mounted refrigeration system with evaporator positioned out of food zone to maximize capacity.

CABINET CONSTRUCTION

- Insulation - Entire cabinet structure and solid door are foamed-in-place using a high density, polyurethane insulation that has zero ozone depletion potential (ODP) and zero global warming potential (GWP).
- Designed to accept roll-in racks (inboard castors) with maximum dimensions of 27"L x 29"D x 72"H (686 mm x 737 mm x 1829 mm)(supplied by others).
- One (1) heavy gauge stainless steel ramp.

DOORS

- Lifetime guaranteed bolt style door locks standard.
- Lifetime guaranteed heavy duty all metal working door handle.
- Positive seal self-closing door with 120° stay open feature. Lifetime guaranteed external cam lift door hinges, Three (3) per door section.
- Magnetic door gasket of one piece construction, removable without tools for ease of cleaning.
- Field reversible hinge.

LIGHTING

- LED interior lighting, safety shielded.

MODEL FEATURES

- Exterior digital temperature display, available with either °F or °C .
- Evaporator epoxy coated to eliminate the potential of corrosion
- Interior bumpers protect cabinet walls from abuse caused by roll-in carts.
- NSF/ANSI Standard 7 compliant for open food product.

ELECTRICAL

- Unit completely pre-wired at factory and ready for final connection to a 115/60/1 phase, 15 amp dedicated outlet. Cord and plug set included.

OPTIONAL FEATURES/ ACCESSORIES

(upcharge & lead times may apply)

- Stainless back. (STR, STA, STG)

METRIC DIMENSIONS ROUNDED UP TO THE NEAREST WHOLE MILLIMETER
 SPECIFICATIONS SUBJECT TO CHANGE WITHOUT NOTICE



Model	Elevation	Right	Plan	3D	Back
ST()2RRI89-2S-HC					