



TRUE MANUFACTURING CO., INC.
U.S.A. FOODSERVICE DIVISION

2001 East Terra Lane • O'Fallon, Missouri 63366-4434 • (636)240-2400
 Fax (636)272-2408 • Toll Free (800)325-6152 • Intl Fax# (001)636-272-7546
 Parts Dept. (800)424-TRUE • Parts Dept. Fax# (636)272-9471 • www.truemfg.com

Project Name: _____

A/A #

Location: _____

Item #: _____ Qty: _____

S/S #

Model #: _____

Model:

TOAM-72GS-HC~NSL01

Open Air Merchandiser:

Glass Sided Refrigerator with Hydrocarbon Refrigerant~Non Standard Look Version 01



TOAM-72GS-HC~NSL01

- ▶ True's open air merchandisers are designed with enduring quality that protects your long term investment.
- ▶ Large, open front allows easy access to display levels and places maximum attention on merchandising.
- ▶ Factory engineered, self-contained refrigeration system using environmentally friendly R290 hydrocarbon refrigerant that has zero (0) ozone depletion potential (ODP), & 0.02 global warming potential (GWP).
- ▶ High capacity, factory balanced refrigeration system that maintains cabinet temperatures of 33°F to 40°F (0.5°C to 4.4°C) for the best in food preservation.
- ▶ True's self-cleaning RCU technology eliminates the need to clean the condenser coil, reduces energy consumption and helps maintain the coldest temperatures and freshest product.
- ▶ Exterior - non-peel or chip black powder coated cold rolled steel; durable and permanent. Interior - attractive, white aluminum liner. Stainless steel interior floor and deck pans.
- ▶ Eight (8) Adjustable, solid white powder coated cantilever shelves. 3-piece, adjustable for up to 15° tilt in 5° increments.
- ▶ LED interior cabinet lighting and under shelf high output LED interior lighting provides more even lighting throughout the cabinet and illuminates product on each shelf.
- ▶ Glass lower front and side panel. Durable and break resistant maximizes product visibility.
- ▶ Entire cabinet structure is foamed-in-place using a high density, polyurethane insulation that has zero ozone depletion potential (ODP) and zero global warming potential (GWP).
- ▶ NSF/ANSI Standard 7 Type II compliant for the storage and/or display of packaged or bottled product; maximum ambient temperature 80°F (27°C).

ROUGH-IN DATA

Specifications subject to change without notice.
 Chart dimensions rounded up to the nearest 1/8" (millimeters rounded up to next whole number).

Model	Shelves	Cabinet Dimensions (inches) (mm)			HP	Voltage	Amps	NEMA Config.	Cord Length (total ft.) (total m)	Crated Weight (lbs.) (kg)
		W	D	H						
TOAM-72GS-HC~NSL01	8	72 1829	29 1/8 738	78 1/2 1994	(3) 3/4 N/A	208-230V/60Hz	14.9 N/A	6-20P	10 3.04	765 347

Requires 208-230/60 Hz, single phase, NEMA 6-20R.
 Unit utilizes three 3/4 Horsepower compressors.



APPROVALS:

AVAILABLE AT:

Model:
TOAM-72GS-HC~NSL01

Open Air Merchandiser:

Glass Sided Refrigerator with Hydrocarbon Refrigerant~Non Standard Look Version 01



STANDARD FEATURES

DESIGN

- Designed using the highest quality materials and components to provide the user with colder product temperatures and lower utility costs in an attractive merchandiser that brilliantly displays packaged food and beverages.

REFRIGERATION SYSTEM

- Factory engineered, self-contained refrigeration system using environmentally friendly R290 hydrocarbon refrigerant that has zero (0) ozone depletion potential (ODP), & 0.02 global warming potential (GWP).
- Time and temperature-initiated, time and temperature-terminated off cycle defrost system.
- High capacity, factory balanced refrigeration system that maintains cabinet temperatures of 33°F to 40°F (0.5°C to 4.4°C) for the best in food preservation.
- State of the art, electronically commutated evaporator and condenser fan motors. ECM motors operate at higher peak efficiencies and move a more consistent volume of air which produces less heat, reduces energy consumption and provides greater motor reliability.
- Bottom mounted condensing unit positioned for easy maintenance.
- True's self-cleaning RCU technology eliminates the need to clean the condenser coil, reduces energy consumption and helps maintain the coldest temperatures and freshest product.

CABINET CONSTRUCTION

- Exterior - non-peel or chip black powder coated cold rolled steel; durable and permanent.
- Interior - attractive, white aluminum liner. Stainless steel interior floor and deck pans.

- Insulation - entire cabinet structure is foamed-in-place using a high density, polyurethane insulation that has zero ozone depletion potential (ODP) and zero global warming potential (GWP).
- Welded, heavy duty steel frame rail, black powder coated for corrosion protection.
- Frame rail fitted with leg levelers.

SHELVING

- Eight (8) adjustable, solid white powder coated cantilever shelves. Each shelf is equipped with an LED light strip to provide 5 levels of even lighting throughout the cabinet
- Cantilever shelving adjustable up to a 15° tilt.

LIGHTING

- LED interior cabinet lighting and under shelf high output LED interior lighting provides more even lighting throughout the cabinet and illuminates product on each shelf.

MODEL FEATURES

- Glass lower front and side panels. Durable and break resistant maximizes product visibility.
- Night cover.
- NSF/ANSI Standard 7 Type II compliant for the storage and/or display of packaged or bottled product; maximum ambient temperature 80°F (27°C).

ELECTRICAL

- Unit completely pre-wired at factory and ready for final connection to a 208-230V / 60 Hz single phase, 20 amp dedicated outlet. Cord and plug set included.



208-230/60/1
NEMA-6-20R

- Unit utilizes a three compressor system rated at ¾HP each.

RECOMMENDED OPERATING CONDITIONS

- Designed to operate in an environment where temperature and humidity do not exceed 80°F (27°C) and 55% relative humidity.
- Unit should not be installed near HVAC vents, fans or doorways that will disrupt the air curtain and compromise the function of the cabinet. Unit should not be installed in direct sunlight.
- Model will run most efficiently when completely loaded with product.
- Drain plumbing hookup recommended. Factory installed condensate pan heater kit available if there is no access to drain plumbing.
- Please be advised Open Air Merchandisers are substantially louder than standard refrigeration models.

OPTIONAL FEATURES/ACCESSORIES

Upcharge and lead times may apply.

- White exterior.
- Stainless steel exterior.
- Black interior liner with black cantilever shelves.
- Stainless steel interior liner with stainless steel cantilever shelves.
- 2 ½" (64 mm) diameter castors (set of 6).
- 4" (102mm) castors
- 5" (127mm) castors
- 6" (153mm) standard legs.
- 6" (153mm) seismic/flanged legs.
- Electric heated condensate pan.
- pricing strips.
- Additional Shelves without lighting.

PLAN VIEW

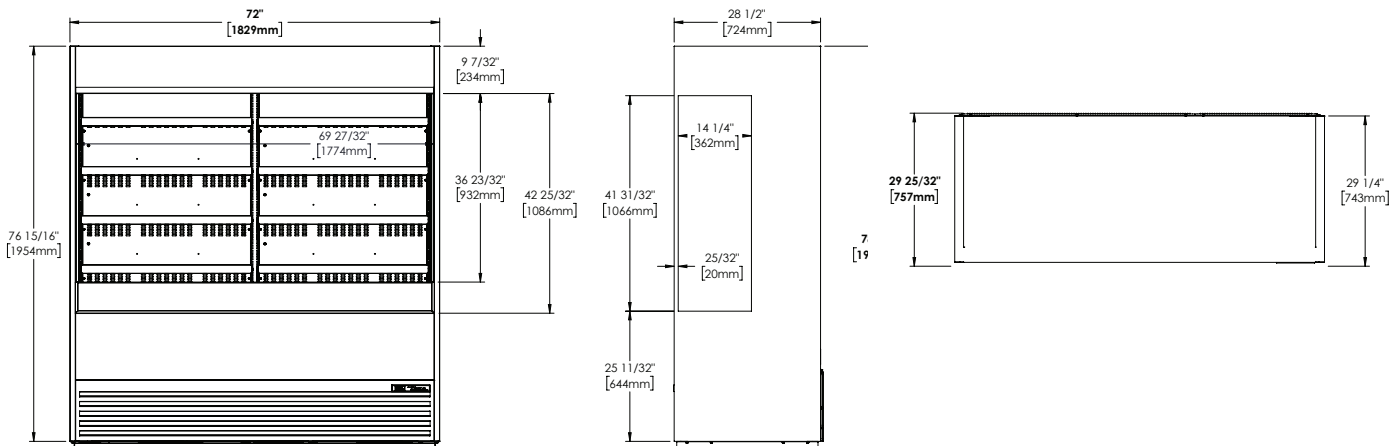

METRIC DIMENSIONS ROUNDED UP TO THE NEAREST WHOLE MILLIMETER

SPECIFICATIONS SUBJECT TO CHANGE WITHOUT NOTICE



Model	Elevation	Right	Plan	3D	Back
TOAM-72GS-HC~NSL01					

TRUE MANUFACTURING CO., INC.

2001 East Terra Lane • O'Fallon, Missouri 63366-4434 • (636)240-2400 • Fax (636)272-2408 • Toll Free (800)325-6152 • Intl. Fax# (001)636-272-7546 • www.truefmfg.com