

# USER GUIDE

SAFETY • INSTALLATION & INTEGRATION • OPERATING INSTRUCTIONS • MAINTENANCE • **SERVICE**

## Parts

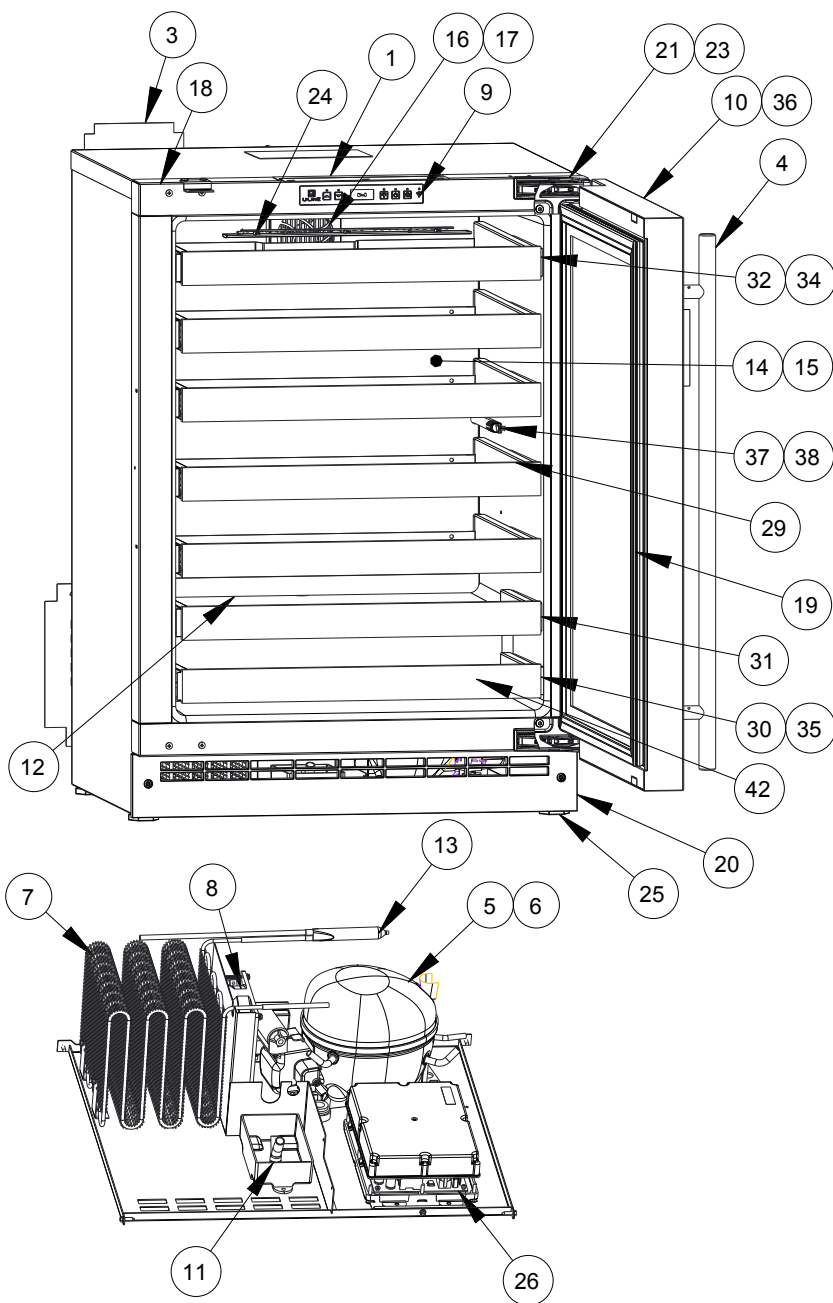

U-2224WCS-13A

Item	Description	U-Line P/N
1	Anti tip brackets w/screws	80-54012-00
2	Keys, baby lock	80-54330-00
3	Back panel	80-54086-00
4	Commercial door Handle	80-54214-00
5	Compressor electricals only	80-54149-00
6	Compressor w/electricals	80-54193-00
7	Condenser assembly	80-54043-00
8	Condenser fan w/screws	80-54014-00
9	Display module	80-54007-00
10	Door assembly w/o hinges	80-54186-00
11	Drain pan w/double sided tape	80-54217-00
12	Drain trough assembly	80-54399-00
13	Drier	80-54055-00
14	Evaporator assembly	80-54057-00
15	Evaporator cover	80-54042-00
16	Evaporator fan	80-54321-00
17	Evap fan w/cover and screws	80-54151-00
18	Frame assembly	80-54820-00
19	Gasket, door, injection molded	80-54039-00
20	Grille w/ screws	80-54040-00
21	Hinge covers (2 pcs)	80-54001-00
22	Hinge mounting hole covers(2)	80-54024-00
23	Hinges (2) w/screws and covers	80-54013-00
24	LED light strip and cover assy	80-54000-00
25	Leg Levelers (4)	80-54019-00
26	Main board (no case or wires)	80-54008-00
27	Packaging	80-54159-00
28	Power cord	80-54171-00
29	Rack assembly	80-54010-00
30	Rack assembly bottom	80-54091-00
31	Rack Assembly, lower	80-54817-00
32	Rack Assembly, middle	80-54818-00
33	Reed switch	80-54134-00
34	Slide assembly, long	80-54047-00
35	Slide assembly, short	80-54048-00
36	Stainless Wrap w/rivets	80-54822-00
37	Thermistor (1 pc)	80-54006-00
38	Thermistor cover and pin	80-54023-00
39	Tool, leg leveler	80-54794-00
40	WIFI antenna	80-54804-00
41	Wire Harness, dual	80-54251-00
42	Wood front w/screws	80-54498-00