

**FEATURES & BENEFITS**



<b>PERFORMANCE</b>	<ul style="list-style-type: none"> <li>• Volume of 6.9 cu ft holds up to 158 bottles (12 oz) or 246 cans (12 oz)</li> <li>• Temperature range: 34°F -70°F</li> <li>• Convection cooling system rapidly and efficiently takes items to the set temperature</li> <li>• U-Select® Control offers five distinct modes: Beverage: 34°F - 65°F, Deli: 34°F - 40°F, Market: 34°F - 40°F, Pantry: 34°F - 70°F, Root Cellar: 45°F - 55°F</li> <li>• U-Select® Control with digital OLED display</li> <li>• Independently controlled dual-zones</li> </ul>
<b>INTERIOR/EXTERIOR</b>	<ul style="list-style-type: none"> <li>• Black interior is illuminated with LED theater lighting that automatically turns off when the door is closed, or can be set to stay on for 3, 6, or 24 hours</li> <li>• Three adjustable tempered glass shelves with 11 height positions in each compartment</li> <li>• Full-extension, slide-out crisper drawers are removable for easy cleaning</li> <li>• LowE coated, argon gas filled triple thermopane glass door provides protection from harmful UV light</li> <li>• Stainless steel handle (7/8" diameter)</li> <li>• Door lock model available</li> <li>• Designed to be built-in (galvanized exterior cabinet)</li> </ul>
<b>INTEGRATION</b>	<ul style="list-style-type: none"> <li>• Robust, concealed and covered hinges with built-in door stop and closer</li> <li>• Adjustable grille can be shifted front-to-back and up-and-down</li> <li>• Integrated model requires 3/4" custom panel of your choice, or can accept U-Line Handleless Stainless Panel Accessory (must be ordered separately)</li> <li>• Grille can accept an integrated toe-kick</li> <li>• Four independently adjustable leveling legs</li> </ul>



STAINLESS FRAME



STAINLESS FRAME (LOCK)



INTEGRATED FRAME (STAINLESS HANDLELESS PANEL)\*



INTEGRATED FRAME

**Model Details**

Model	Voltage/Hz	Door Swing	Finish	Shipping Weight
U-3036RRGLS-00B	115 / 60	Double Doors	Stainless Frame	229 lb
U-3036RRGLS-13B	115 / 60	Double Doors	Stainless Frame (Lock)	229 lb
U-3036RRGLINT-00B	115 / 60	Double Doors	Integrated Frame	217 lb

**Accessories**

Model	Description	Finish	Shipping Weight
ULASHP18FRAME*	Stainless Handleless Panel Frame (single panel)	Stainless	6 lb

\*Installs on integrated models, 2 panels required.

## DIMENSIONS

Dimensions shown apply to all finishes, including Integrated (INT) models with 3/4" integrated panel/frame installed.

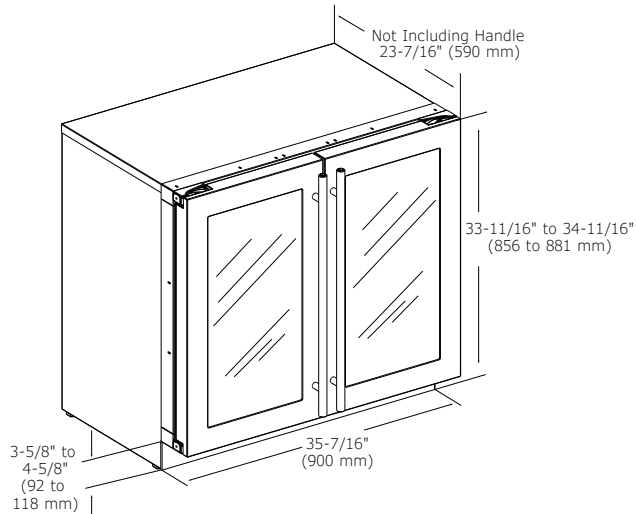

## CABINET CUT-OUT

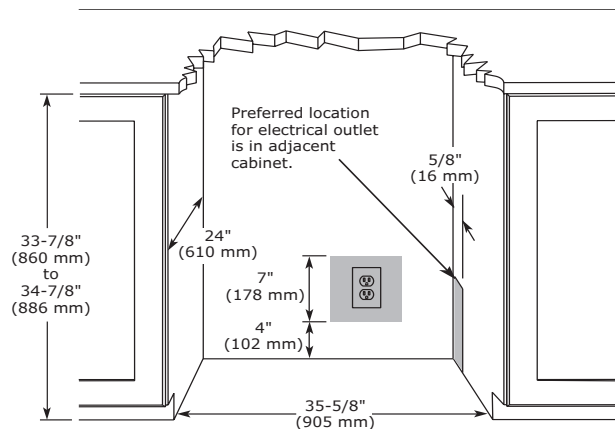

## INSTALLATION NOTES

When installing adjacent to wall, ensure 2 1/2" clearance on hinged side for 90° door opening, allowing ample room for door handle.

No additional clearance around sides, top or rear of unit is needed for ventilation.

Do not obstruct front grille air flow.

## WARRANTY

- 1 Year (parts & labor) / 5 year sealed system (parts)
- + **Additional 1 Year (parts & labor) warranty at no cost with product registration**

See complete warranty for details

## SPECIFICATIONS

Model	3036RRGL
Amps: Running	1.2
Capacity: Bottle (12 oz)	158
Capacity: Can (12 oz)	246
Capacity: Volume (cu ft)	6.9
Control Type	U-Select®
Dimensions: Product Depth	23 7/16" / 590 mm
Dimensions: Product Height	33 11/16" / 856 mm
Dimensions: Product Width	35 7/16" / 900 mm
Energy Consumption: Avg. Per Year	320 kWh
ENERGY STAR	No
Panel Height	30" / 762 mm
Panel Thickness	3/4" / 20 mm
Panel Type	2 3/4" / 70 mm Frame Panel
Panel Width	17 5/8" / 445 mm
Product Weight: Max	203 lb
Refrigerant Type	R600a (1.34 oz)
Sabbath (Star K Certified)	Yes
Temperature Range	34°F - 70°F

## COOLING SYSTEM



## ELECTRICAL REQUIREMENTS

This unit requires a grounded, polarized 115 VAC, 60 Hz, 15 A power supply (normal household current).

