

USER GUIDE

SAFETY • INSTALLATION & INTEGRATION • OPERATING INSTRUCTIONS • MAINTENANCE • **SERVICE**

Parts

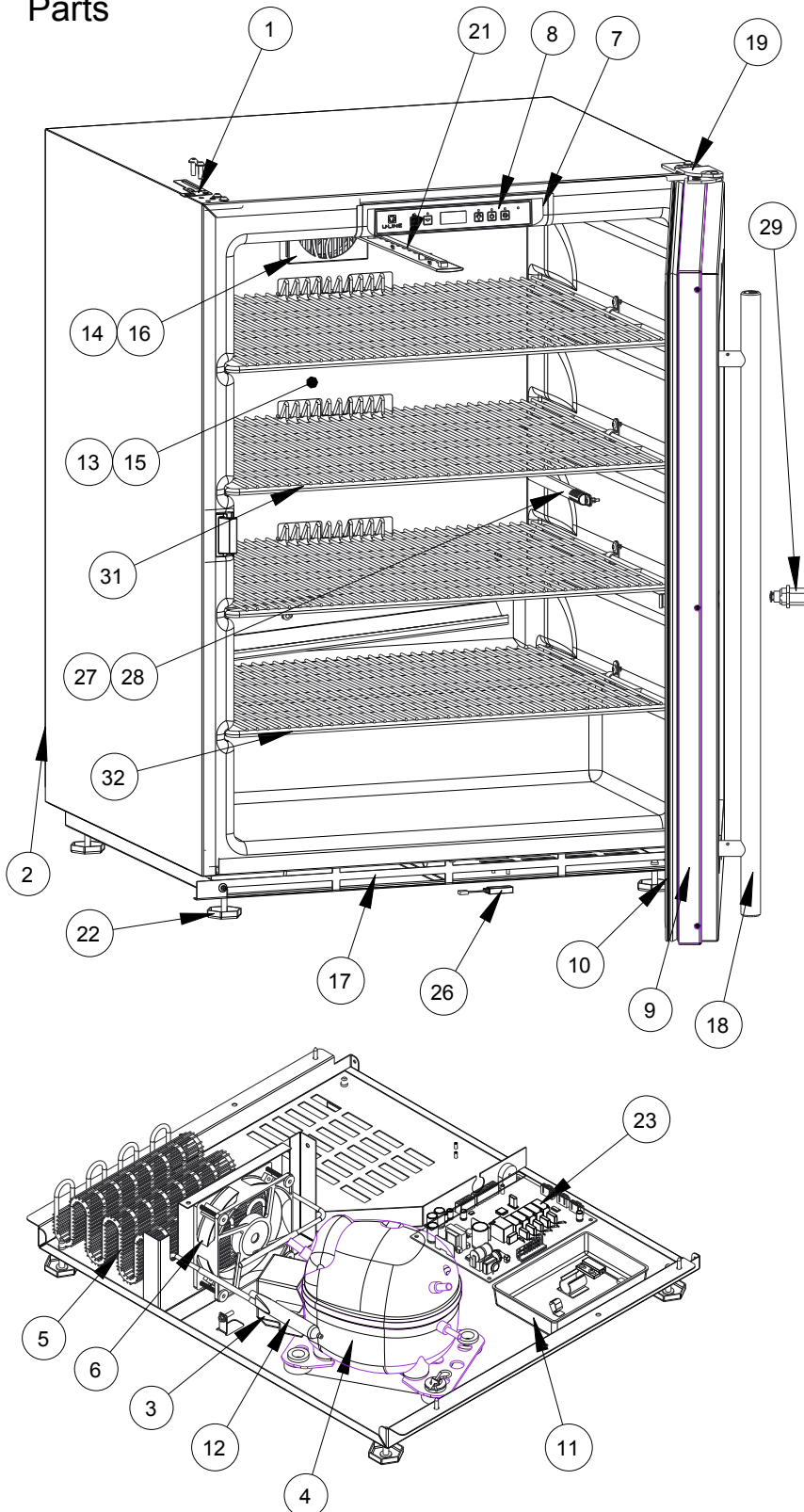

U-ADA24RGLB-13B

Item	Description	U-Line P/N
1	Anti tip bracket w/screws	80-54239-00
2	Back panel	80-54324-00
3	Compressor electricals only	80-54149-00
4	Compressor w/electricals	80-54150-00
5	Condenser assembly	80-54322-00
6	Condenser fan w/screws	80-54014-00
7	Control Housing	80-54259-00
8	Display module	80-54236-00
9	Door assembly w/hinges	80-54331-00
10	Gasket, door	80-54213-00
11	Drain pan w/double sided tape	80-54323-00
12	Drier	80-54055-00
13	Evaporator assembly	80-54275-00
14	Evaporator fan cover w/screws	80-54320-00
15	Evaporator cover	80-54319-00
16	Evaporator fan	80-54321-00
17	Grille w/screws	80-54325-00
18	Handle w/logo	80-54214-00
19	Hinges (2) w/screws	80-54208-00
20	Keys, babylock	80-54330-00
21	LED light strip and cover assy	80-54000-00
22	Leg Levelers (4)	80-54201-00
23	Main board (no case or wires)	80-54008-00
24	Packaging	80-54209-00
25	Power cord	80-54171-00
26	Reed switch assembly	80-54134-00
27	Thermistor (1 pc)	80-54006-00
28	Thermistor cover and pin	80-54237-00
29	Universal lock assembly	80-54153-00
30	Wire harness, board	80-54251-00
31	Wire shelf w/clips(1)	80-54328-00
32	Wire shelf btm, w/clips(1)	80-54329-00