

49 cu ft Freezers, Reach-In

CFZ553-SS: Solid Door Freezer, Reach-In

CFZ553-SG: Glass Door Freezer, Reach-In



CFZ553-SS



CFZ553-SG

Features and Specifications

Volume of 49 cu ft comfortably fits 18" x 26" sheet pans
AISI 304 Stainless steel interior and exterior with locks
Temperature range: -13°F to 14°F
Electronic digital temperature control with alarms
Autodefrost
High efficiency top-mounted compressor with 9.6 running amps
High efficiency evaporator coil & condenser
Self-lubricating, sealed cast iron evaporator fan motor with high volume air flow design
Removable magnetic gasket for easy cleaning
CFC-free high-density polyurethane insulated cabinet
Factory pre-wired for dedicated outlet, 11 ft cord and plug included NEMA 5-15P
Environmentally friendly R290 refrigerant - 4.2 oz (0.120kg)
2 sections, includes 6 epoxy coated wire shelves
Dimensions: 82 9/32" H x 52 9/16" W x 31 1/2" D
LED lighting
6 Adjustable stainless steel legs

Model Details

Model	Description	Voltage/Hz	Shipping Weight
UCFZ553-SS71A	49 cu ft Freezer Solid Door, Reach-In	115v / 60hz	441 lb
UCFZ553-SG71A	49 cu ft Freezer Glass Door, Reach-In	115v / 60hz	617 lb

Accessories

Model	Description	Shipping Weight
ULA4080534	Shelf Guide	.88 lb
ULAQ32-0002	Epoxy Coated Wire Shelf (20.86" x 25.6")	2.2 lb
ULA81040300	Caster Kit (6 casters, 2 with brakes)	11.02 lb



Product Specifications • 49 cu ft Freezers, Reach-In

Front

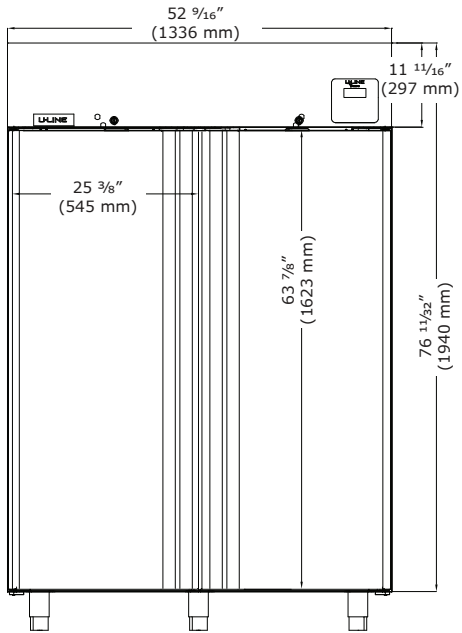

**Front
(Closed - Glass Door)**

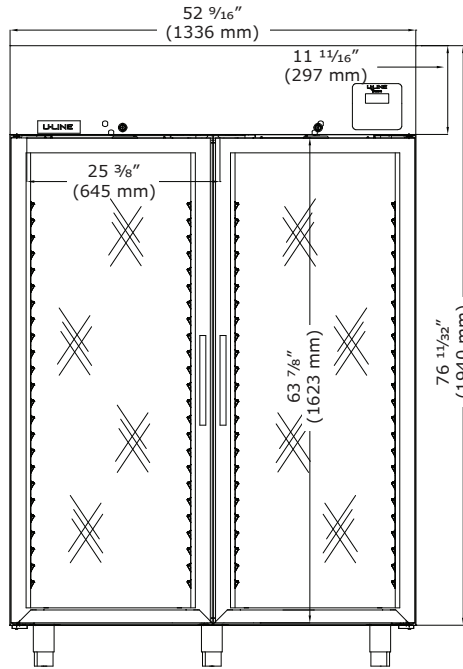

Side

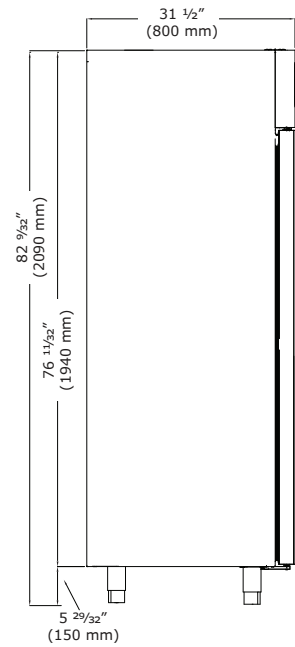

Top

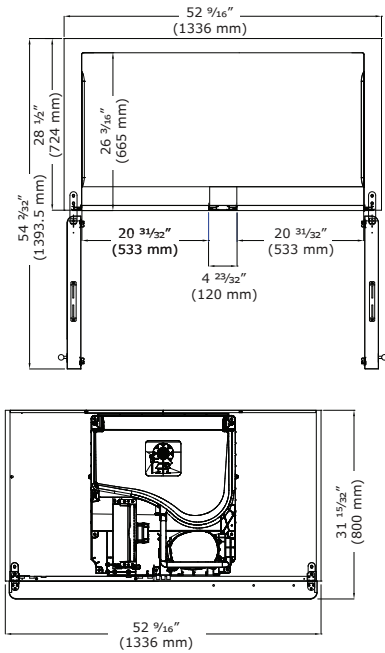

Back

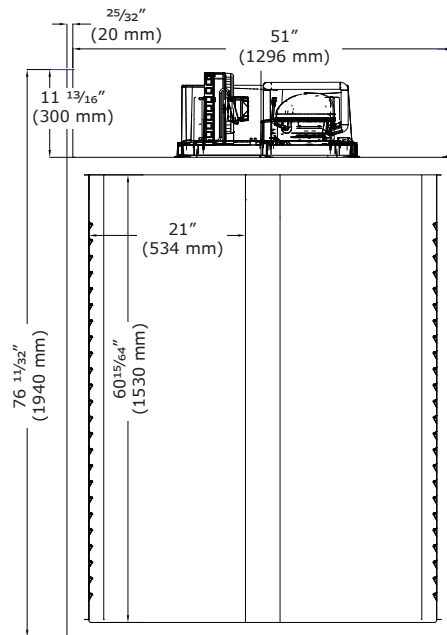

Side

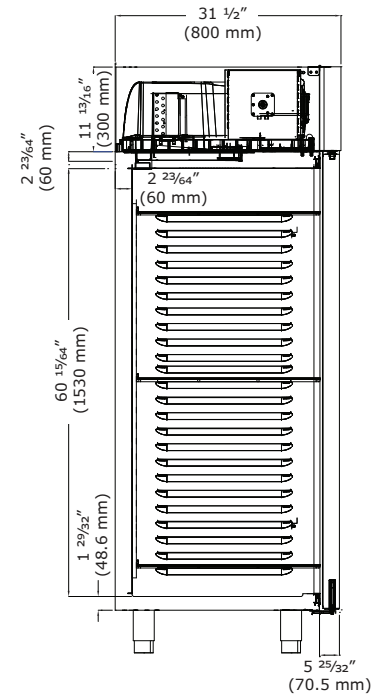

Commercial Warranty

1 Year (parts & labor) / 5 year sealed system (parts)
See complete warranty for details

