

QUICK START GUIDE



DISPENSERS • HDE215 (115v) • 2 Tap Coffee

QUICK START GUIDE

WELCOME TO U-LINE

Congratulations on your U-Line purchase. Your product comes from a company with over five decades of premium modular ice making, refrigeration, and wine preservation experience. U-Line continues to be the American leader, delivering versatility and flexibility for multiple applications including residential, light commercial, outdoor and marine use. U-Line's complete product collection includes Wine Captain® Models, Beverage Centers, Clear Ice Machines, Nugget Ice Machines, Crescent Ice Makers, Glass & Solid Door Refrigerators, Drawer Models, Freezers, Combo® Models, and more.

U-Line has captivated those with an appreciation for the finer things with exceptional functionality, style, inspired innovations and attention to even the smallest details. We are known and respected for our unwavering dedication to product design, quality and selection. U-Line is headquartered in Milwaukee, Wisconsin and has shipped product to five continents for over two decades and is proud to have the opportunity to ship to you.

PRODUCT INFORMATION

Looking for additional information on your product? User Guides, Spec Sheets, CAD Drawings, Compliance Documentation, and Product Warranty information are all available for reference and download at u-line.com.

PROPERTY DAMAGE / INJURY CONCERNS

In the unlikely event property damage or personal injury is suspected related to a U-Line product, please take the following steps:

1. U-Line Customer Care must be contacted immediately at +1.800.779.2547.
2. Service or repairs performed on the unit without prior written approval from U-Line is not permitted. If the unit has been altered or repaired in the field without prior written approval from U-Line, claims will not be eligible.

GENERAL INQUIRIES

U-Line Corporation
8900 N. 55th Street
Milwaukee, Wisconsin 53223 USA
Monday - Friday 8:00 am to 4:30 pm CST
T: +1.414.354.0300
F: +1.414.354.7905
Email: sales@u-line.com
u-line.com

SERVICE & PARTS ASSISTANCE

Monday - Friday 8:00 am to 4:30 pm CST
T: +1.800.779.2547
F: +1.414.354.5696
Service Email: onlineservice@u-line.com
Parts Email: onlineparts@u-line.com

CONNECT WITH US



Designed, engineered and assembled in WI, USA

QUICK START GUIDE

This Quick Start Guide covers the basics of installation and general use of your product.

CONTENTS

Safety and Warning	4
Environmental Requirements	5
Electrical	5
Door Swing	5
Door Adjustments	6
General Installation	8
Control Operation	15
First Use	15
Airflow & Product Loading	18
Cleaning	18
Warranty	20

For more details, see the complete User Guide & Service Manual on u-line.com.



This product is eligible for an additional one-year warranty at no charge when you register your product on u-line.com. See complete warranty for details.

QUICK START GUIDE

Safety and Warning

NOTICE

Please read all instructions before installing, operating, or servicing the appliance.

Use this appliance for its intended purpose only and follow these general precautions with those listed throughout this guide:

SAFETY ALERT DEFINITIONS

Throughout this guide are safety items labeled with a Danger, Warning, or Caution based on the risk type:



Danger means that failure to follow this safety statement will result in severe personal injury or death.



Warning means that failure to follow this safety statement could result in serious personal injury or death.



Caution means that failure to follow this safety statement may result in minor or moderate personal injury, property, or equipment damage.



This unit contains R600a (Isobutane) which is a flammable hydrocarbon. It is safe for regular use. Do not use sharp objects to expedite defrosting. Do not service without consulting the "R600a specifications" section included in the User Guide. Do not damage the refrigerant circuit.



Service must be done by factory authorized service personnel. Any parts shall be replaced with like components. Failure to comply could increase the risk of possible ignition due to incorrect parts or improper service.

CALIFORNIA PROPOSITION 65

This product contains chemicals known to the state of California to cause cancer and birth defects or other reproductive harm.

www.P65warnings.CA.gov

QUICK START GUIDE

Environmental Requirements

This model is intended for indoor/interior applications only and is not to be used in installations that are open/exposed to natural elements.

This unit is designed to operate between 50°F (10°C) and 100°F (38°C). Higher ambient temperatures may reduce the unit's ability to reach low temperatures and/or reduce ice production on applicable models.

For best performance, keep the unit out of direct sunlight and away from heat generating equipment.

In climates where high humidity and dew points are present, condensation may appear on outside surfaces. This is considered normal. The condensation will evaporate when the humidity drops.



Damages caused by ambient temperatures of 40°F (4°C) or below are not covered by the warranty.

Electrical

SHOCK HAZARD — Electrical Grounding Required. Never attempt to repair or perform maintenance on the unit until the electricity has been disconnected.

Never remove the round grounding prong from the plug and never use a two-prong grounding adapter.

Altering, cutting or removing power cord, removing power plug, or direct wiring can cause serious injury, fire, loss of property and/or life, and will void the warranty.

Never use an extension cord to connect power to the unit.

Always keep your working area dry.

NOTICE

Electrical installation must observe all state and local codes. This unit requires connection to a grounded (three-prong), polarized receptacle that has been placed by a qualified electrician.

The unit requires a grounded and polarized 115 VAC, 60 Hz, 15A power supply (normal household current). An individual, properly grounded branch circuit or circuit breaker is recommended. A GFCI (ground fault circuit interrupter) is usually not required for fixed location appliances and is not recommended for your unit because it could be prone to nuisance tripping. However, be sure to consult your local codes.

See CUTOUT & PRODUCT DIMENSIONS for recommended receptacle location.

Door Swing

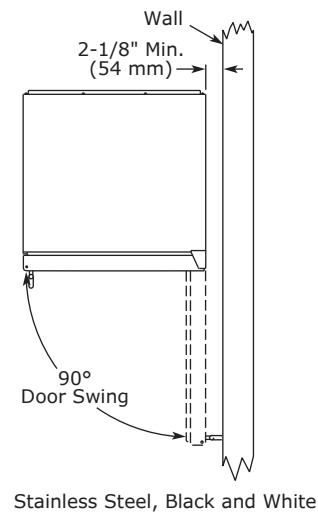

Units have a zero clearance for the door to open 90°, when installed adjacent to cabinets.

Stainless steel models require 2-1/8" (54 mm) door clearance to accommodate the handle if installed next to a wall.

QUICK START GUIDE

Door Adjustments

HINGE COVER

Hinge cover included with the literature bag is optional.

To install hinge cover:

Press hinge cover squarely over hinge

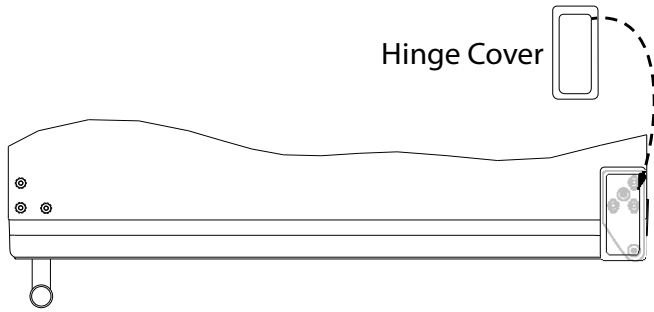

DOOR ALIGNMENT AND ADJUSTMENT

Align and adjust the door if it is not level or is not sealing properly. If the door is not sealed, the unit may not cool properly, or excessive frost may form in the interior.

NOTICE

Properly aligned, the door's gasket should be firmly in contact with the cabinet all the way around the door (no gaps). Carefully examine the door's gasket to ensure that it is firmly in contact with the cabinet. Also make sure the door gasket is not pinched on the hinge side of the door.

To align and adjust the door:

1. Gently pry off hinge cover from top of unit.
2. Loosen (do not remove) top and bottom hinge screws using a Torx T-25 screwdriver on the top and a 1/4" socket on the bottom.
3. Align door squarely with cabinet.
4. Make sure gasket is firmly in contact with cabinet all the way around the door (no gaps).
5. Tighten bottom hinge screws.

6. Tighten top hinge screws and replace hinge cover.

REVERSING THE DOOR

Location of the unit may make it desirable to mount the door on the opposite side of the cabinet.

The hinge hardware will be removed and reinstalled on the opposite side of the cabinet.

TO REVERSE THE DOOR

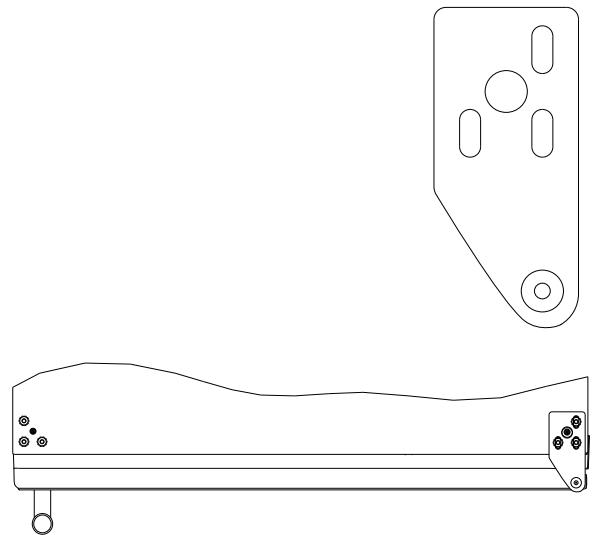

Remove top hinge and door:

1. Remove hinge cover from top of unit.
2. Hold door to keep it from falling.
3. Remove top hinge from cabinet using a Torx T-25 screwdriver to remove three screws. Set aside and save for possible future use.

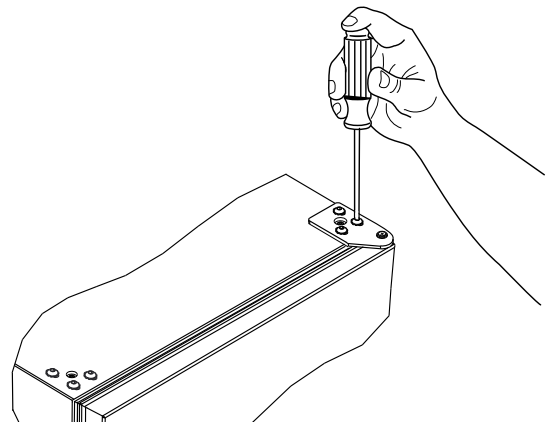

QUICK START GUIDE

4. Remove door by tilting forward and lifting door off bottom hinge. Retain shoulder washers; they will be reused.
5. Remove three screws from hinge holes on the opposite side. Reinstall into holes where the hinge was removed. Take care not to scratch cabinet.

Remove bottom hinge:

1. Remove bottom hinge from cabinet using 1/4" socket.

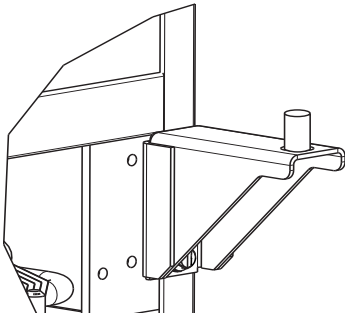

2. Remove corresponding screws on opposite side of cabinet. On some models there may be a nut behind one or both screws on either side.

Install bottom hinge:

Install two or three screws, depending on model. Replace nuts if used.

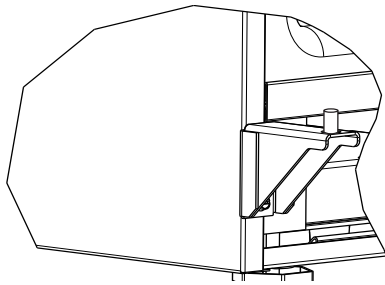

Prepare door for reinstallation:

1. Remove gasket.
2. Rotate gasket 180° and press firmly into the gasket channel starting at the corners.
3. Rotate door 180° to reverse.

Install top hinge and door:

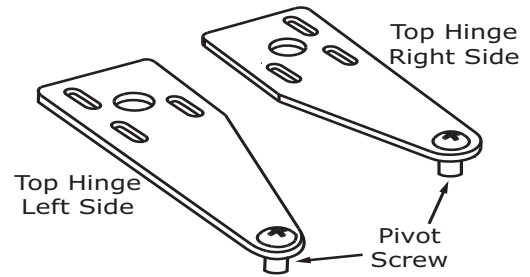

1. Remove pivot screw from hinge, flip hinge over, and install the pivot screw in the same hole from the opposite surface.

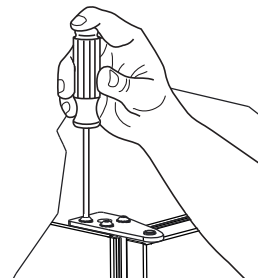

2. Rotate door 180° and lift the door onto the bottom hinge.
3. Align edge of the hinge with the outer edge of the unit.
4. Tighten three screws and replace hinge cover.

Align and adjust the door:

Align and adjust the door (see DOOR ALIGNMENT AND ADJUSTMENT).

QUICK START GUIDE

General Installation

The following components are shipped inside the unit:

1. Double Tower (faucets, handles, gaskets, & hardware)
2. Nitrogen regulator (hose and valve)
3. Infuser regulator (hoses & hardware)
4. Liquid jumper line (with in-line filter) and gas jumper line
5. 2.5-gallon ball tap keg (you may use 3-gallon or 5-gallon keg)
6. Drip tray
7. Cleaning solution (2-ounce packet)
(Additional cleaner, ULACOFFEECLEAN, is available at u-line.com)

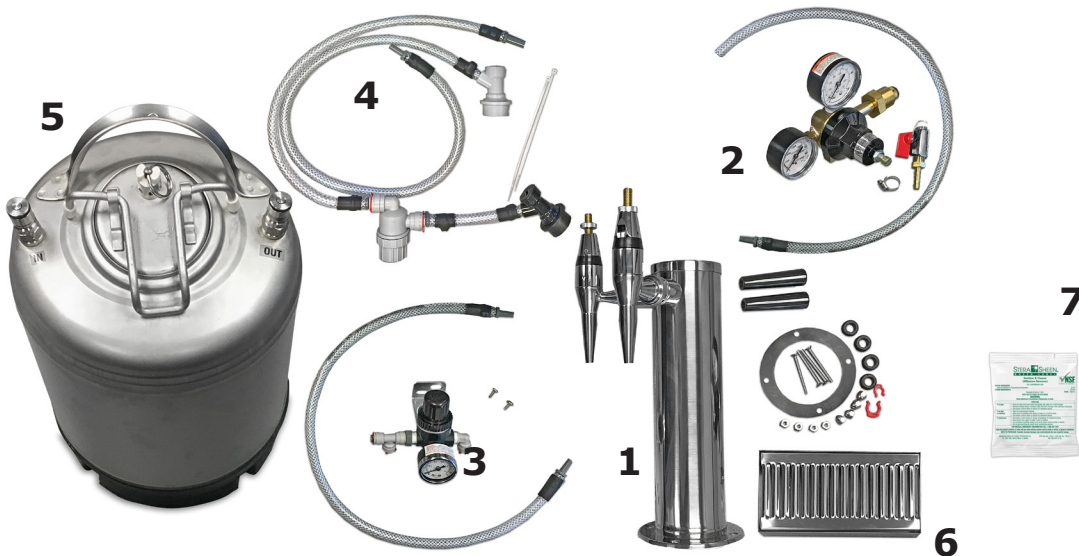

Required (not included):

1. Nitrogen tank with food grade nitrogen - available at your local gas supplier. 22 cubic feet aluminum empty tank available (ULANITROTANK) at u-line.com.



Safety and Warning



Keep nitrogen tank in an upright position and handle with care.

Never exceed 60 PSI.

Ventilate area after nitrogen leak.

2. Your favorite cold coffee or tea.

QUICK START GUIDE

Install Tower on Free-Standing Refrigerator

If your refrigerator is new out of the box, do not remove all the protective film on the stainless exterior until the tower is installed.

1. Remove four Phillips screws (secured with nuts on the inside of the refrigerator) and lift off cap to reveal tower mounting hole. Peel back enough film for tower to clear.

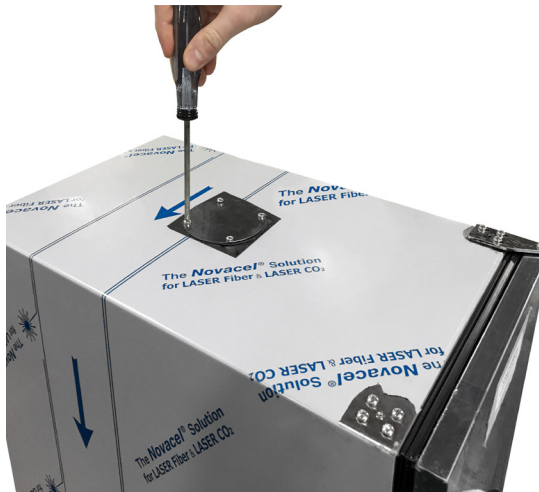

3. Screw the handles onto the faucets and continue to assemble and connect regulator to Nitrogen tank.



2. Position gasket over mounting hole and install tower using four Phillips screws and nuts.



QUICK START GUIDE

Install Tower on Countertop

(See template on next page)

Note: These instructions are designed for a standard 36" countertop application.

Note: For a customized fit, it may be necessary to acquire screws that are sized to the thickness of your countertop.

1. Position keg refrigerator under countertop to determine the desired depth.
2. Use the dimensions from Diagram A to determine the center point of the tower mounting hole.
3. Remove keg refrigerator from under countertop.
4. Use template to drill four mounting holes.
5. Drill 3-1/8" diameter hole through countertop.
6. Secure tower to countertop.
7. Screw the handles onto the faucets and continue to CONNECTIONS in this User Guide.



Diagram A

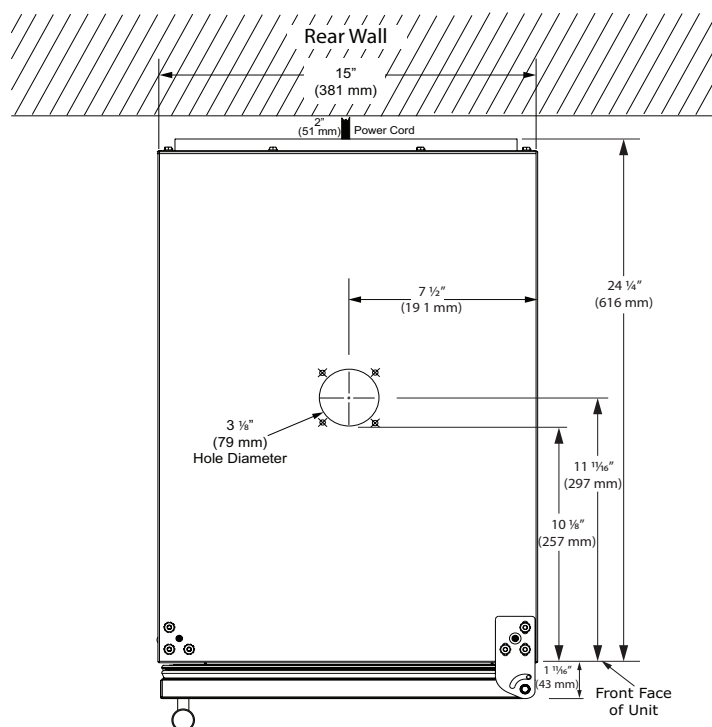
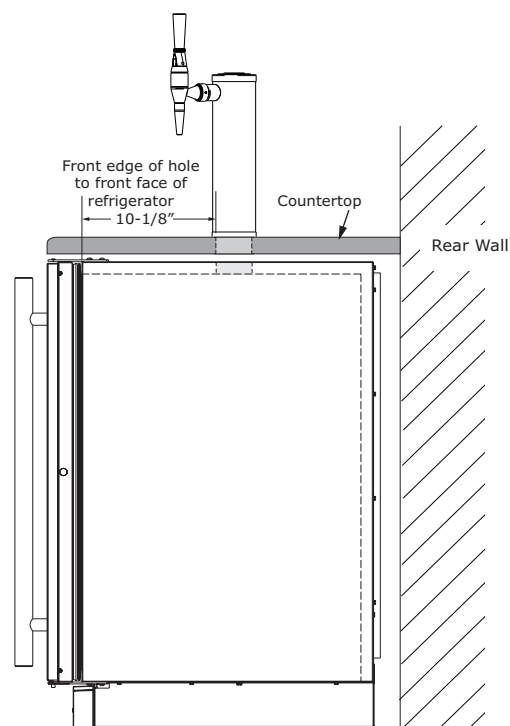

Diagram B



QUICK START GUIDE

Template for Countertop Installation

Note: Verify template has printed true to scale - double check hole dimensions and placement.

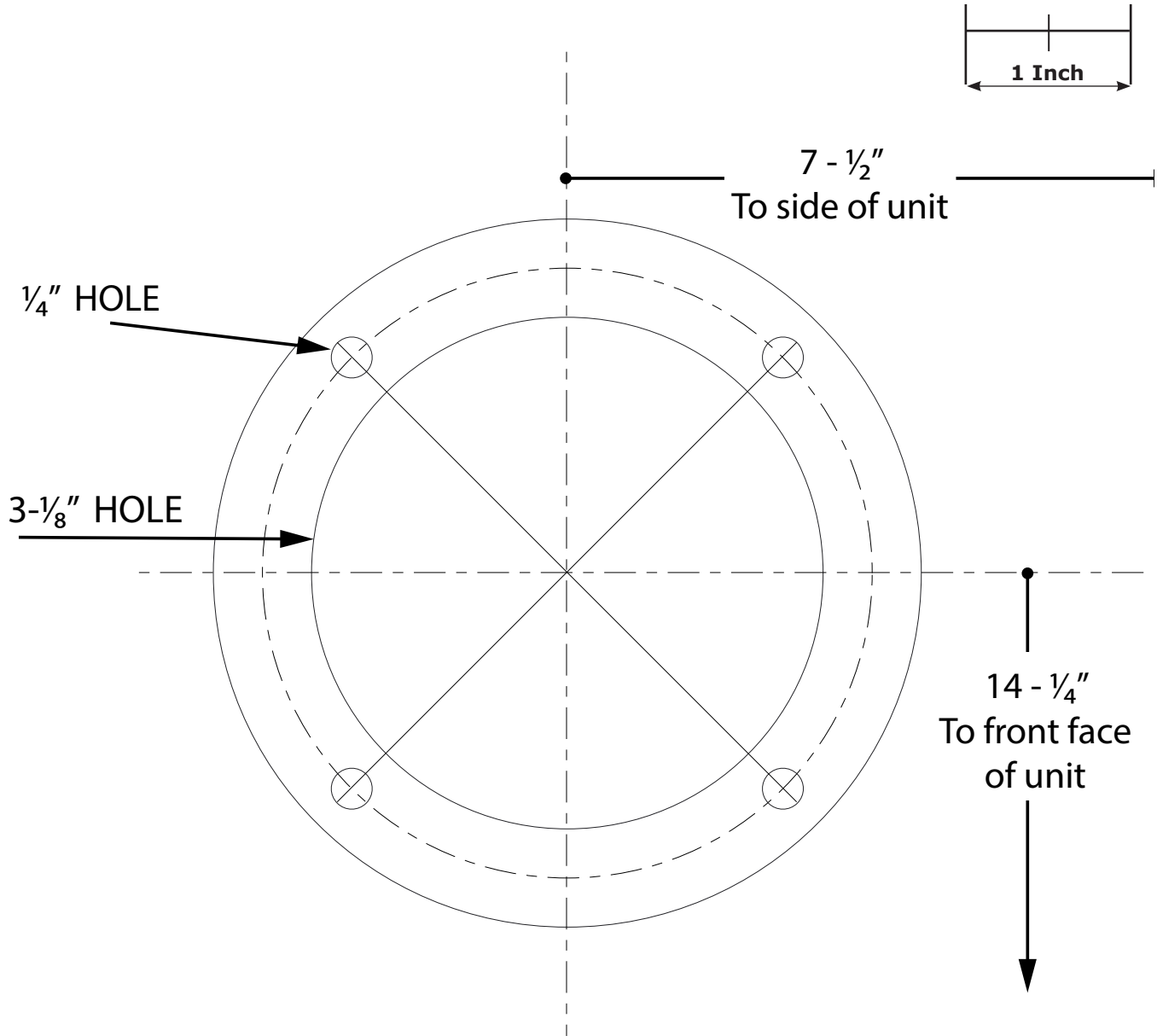

QUICK START GUIDE

Assemble and Connect Regulator to Nitrogen Tank

1. Attach ball valve to tank regulator. Tighten with an adjustable wrench. Make sure valve is in the off position - turned clockwise as far as it can go.

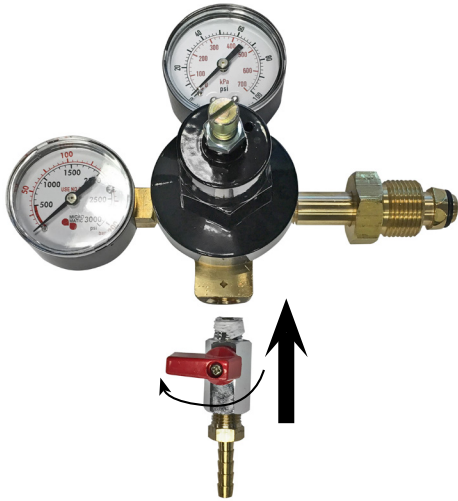

2. Attach regulator to nitrogen tank. Hand tighten the coupling nut and then use an adjustable wrench for an additional quarter turn. DO NOT OVER TIGHTEN

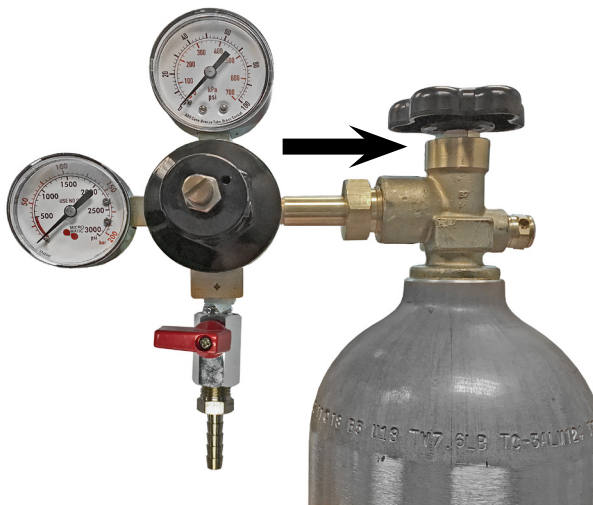

Connect Keg to Dispenser Tower

1. Attach black nitrogen coupler of the liquid jumper line to keg. With your thumb on top of the coupler, pull up on collar and press coupler down firmly onto out valve. Release collar - listen for a click. Pull up on the coupler to ensure it is locked down.

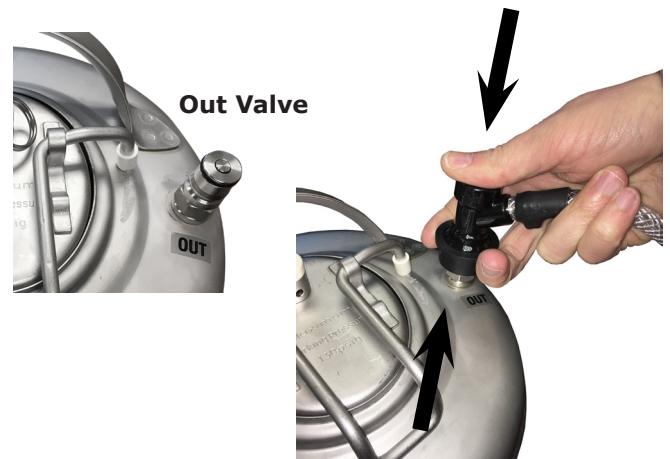

2. Attach other end of beverage hose to "Y" connection within dispenser tower - line up and press in firmly.

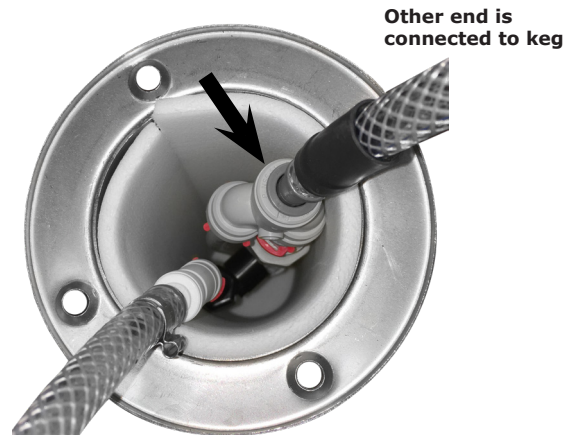

3. Attach hose to elbow connector on infuser regulator.

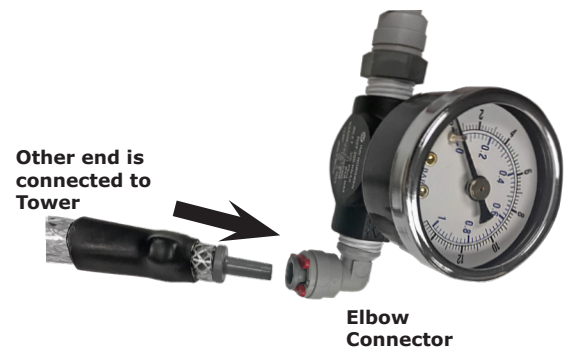

QUICK START GUIDE

4. Attach other end of hose to the single connection within the beverage tower.



3. Attach gray coupler of the gas jumper line to keg. With your thumb on top of the coupler, pull up on collar and press coupler down firmly onto in valve. Release collar - listen for a click. Pull up on the coupler to ensure it is locked down.



Connect Nitrogen Tank to Keg

1. Attach nitrogen line to ball valve on tank regulator. Make sure valve is in the off position - turned clockwise as far as it can go. Tighten hose clamp.



4. Attach other end of gas jumper line to T connector on infuser regulator - line up and press in firmly.

2. Attach other end of nitrogen line to T connector on infuser regulator - line up and press in firmly.



QUICK START GUIDE

Connections

When complete, the connections should look like this:

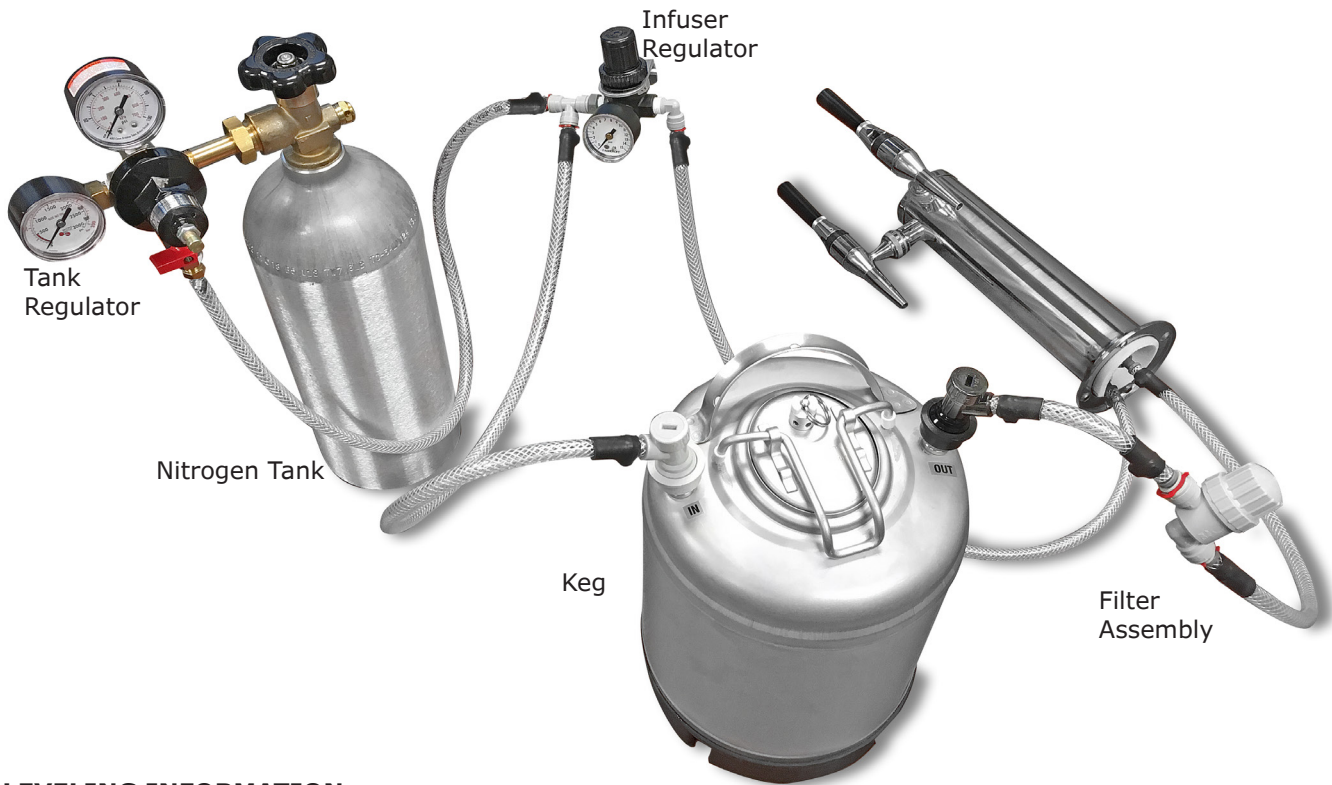

LEVELING INFORMATION

1. Use a level to confirm the unit is level. Level should be placed along top edge and side edge as shown.

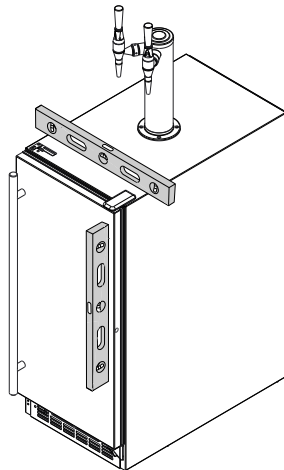

3. Confirm the unit is level after each adjustment and repeat the previous steps until the unit is level.

When ready to use, see **FIRST USE** section in this manual.

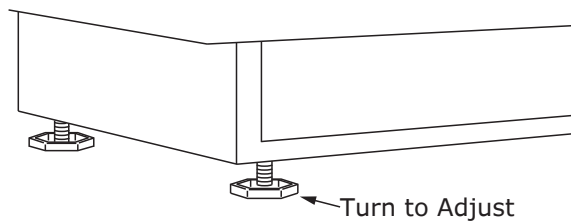

QUICK START GUIDE

Control Operation

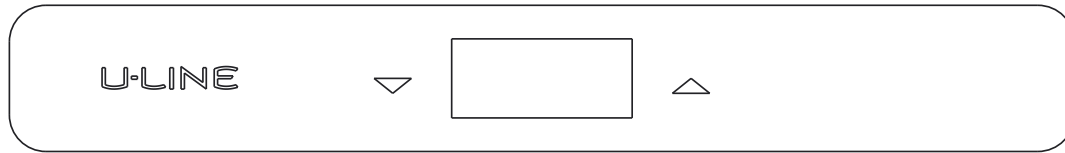

CONTROL FUNCTION GUIDE

FUNCTION	COMMAND	NOTES
ON/OFF	Press ▾ and hold for 5 seconds	Unit will turn On or OFF
Adjust Temperature	Press ▲ or ▾ and release	When the display is flashing, press ▲ or ▾ to adjust the set point temperature. Note: temperature displayed is the actual temperature inside unit
Toggle between °F / °C	Hold ▲ and ▾ for 5 seconds	The display will change units

First Use

Initial startup requires no adjustments. If the unit was turned off, press and hold ▾ for 5 seconds to turn unit on. See "Control Operation" section for more details.

NOTICE

Temperature displayed reflects actual temperature inside unit.

If the temperature displayed is different than selected, the unit is progressing towards the selected temperature. Time to reach set point varies based upon ambient temperature, temperature of product loaded, door openings, etc. U-Line recommends allowing the unit to reach set points before loading.

To dispense cold coffee, make sure the components are assembled according to the instructions in GENERAL INSTALLATION.

Fill the Keg

DE-PRESSURIZE SYSTEM

NOTICE

Before attempting to fill the keg it is necessary to confirm system is not pressurized.

1. Shut off nitrogen tank by turning handle clockwise until it stops.



2. Lift up on pressure release valve ring. Allow pressure to release.



3. Detach hoses from keg. (See General Installation section of this guide.)

QUICK START GUIDE

- Remove keg from refrigerator.
- Lift handle and remove lid.



- Fill keg with cold brew.
- Replace and lock down lid.
- Reattach hoses.

Set Nitrogen Pressure

The pressure should be set around 20 - 30 PSI. Start at 25 PSI on regulated gauge; 7 PSI at infuser regulator.

- Make sure red regulator valve is in the OFF position.

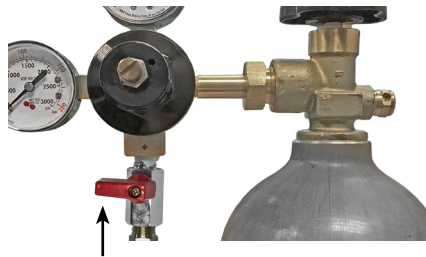

- On top of Nitrogen tank, turn black handle counterclockwise until it stops.
- Rotate the red regulator valve to ON Position; turn counterclockwise 1/4 turn until it stops

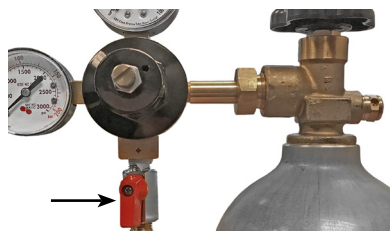

TO ADJUST PRESSURE

- Loosen locking nut, turn adjusting screw until desired pressure is reached, and retighten locking nut.

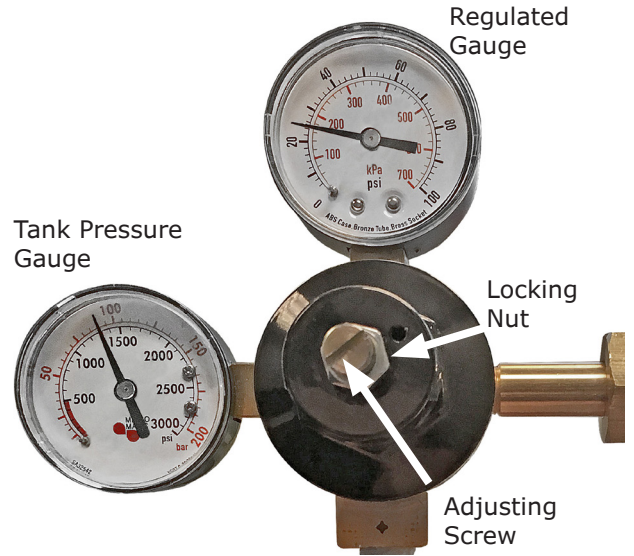

- On infuser regulator, pull out middle knob to unlock then turn knob until needle points at 7 - turn right to increase; left to decrease.

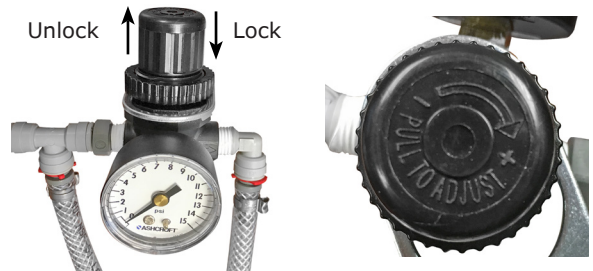

- Once set, lock in place by pressing middle knob in until it clicks.

QUICK START GUIDE

Dispensing Coffee

The left tap delivers still cold brew which is refreshing and less acidic than hot coffee. The right tap delivers nitrogen-infused coffee which is the ultimate cold brew experience. Thousands of micro-nitrogen bubbles are infused as the coffee is dispensed. This creates a naturally slightly sweet taste and thicker and smoother texture.

Troubleshooting

ISSUE	CAUSE	SOLUTION
No/reduced liquid flow through faucet(s).	The strainer inside of the filter bowl assembly is clogged or beginning to clog.	See cleaning section
	Nitrogen source is empty or turned off.	If applicable, assure that the nitrogen tank is not empty and that the nitrogen shutoff switch is in the on position (in-line with the tube). Also assure that the knob on top of the tank is turned all the way counterclockwise. If the tank is empty, replace it with a full one.
	Liquid and/or nitrogen ball lock disconnects are not fully connected to product tank.	Attach the liquid/nitrogen ball lock disconnects to the product tank. If they already appear to be connected, disconnect/reconnect them.
	The nose cone of the faucet is clogged.	Detach the nose cone assembly from the stout faucet by turning it counterclockwise. Remove the stainless steel restrictor disc and inspect the small holes to assure that none of them are clogged.
	The system is dirty and requires a thorough line cleaning/sanitizing procedure.	Follow the line cleaning procedure above to remove buildup and restore full flow.
Too much or not enough nitrogen being infused into the product (head is too big or too small).	The secondary regulator is set to a pressure that is either too high or low.	If there is less/more nitro effect than desired, use the black knob on the secondary regulator assembly to make a change. To adjust the secondary regulator, pull the black knob out until you feel a slight click. This is the adjustment mode. To increase the level of nitro, turn this knob clockwise. To decrease the level of nitro, turn the knob counterclockwise. Continue adjusting and pouring until the level of nitro meets your requirements. Once you have found your desired level of nitrogenation, push the black knob back in to lock it in place.
	The strainer inside of the filter bowl assembly is beginning to clog.	See cleaning section
	The system is dirty and needs cleaned.	See cleaning section
Liquid leak.	Loose connection, broken fitting/tube, or loose faucet, nose cone or filter bowl assembly.	Immediately turn the nitrogen off to the system, disconnect the quick disconnects from the product tank and call customer support for consultation to assess the system.
Nitrogen leak (system is using nitrogen even when faucets are closed).	Product tank lid is not sealed completely.	Remove the lid and reattach making sure that the lid is centered and sealed.
	Fitting is loose, disconnected, or broken.	Immediately turn the nitrogen off to the system, disconnect the quick disconnects from the product tank and call customer support for consultation to assess the system.
The product is pouring too warm/cold or is freezing in the lines.	Hot/Warm - The refrigeration is not plugged in or turned on.	Plug in the refrigerator and assure it is powered on.
	Frozen - The thermostat on the refrigeration needs adjusted.	See control section
	The condenser coil on the refrigeration is dirty and needs cleaned.	See condenser cleaning

QUICK START GUIDE

Airflow and Product Loading

AIRFLOW

External

- Do not block the front grille - no additional clearance around sides, top or rear of unit is needed for ventilation
- Do not install behind a closed door

Internal

- When loading, leave space between internal fans, vents, and side walls to allow air to circulate freely

NOTICE

Restricting airflow may result in poor product performance, product failure, and uneven internal temperatures and may freeze contents.

Cleaning

Stainless Models

Stainless door panels, handles and frames can discolor when exposed to chlorine gas, pool chemicals, saltwater or cleaners with bleach.

Keep your stainless unit looking new by cleaning with a good quality all-in-one stainless steel cleaner and polish monthly. For best results use Claire® Stainless Steel Polish and Cleaner. Comparable products are acceptable. Frequent cleaning will remove surface contamination that could lead to rust. Some installations may require cleaning weekly.

Do not clean with steel wool pads.

Do not use stainless steel cleaners or polishes on any glass surfaces.

Clean any glass surfaces with a non-chlorine glass cleaner.

Do not use cleaners not specifically intended for stainless steel on stainless steel surfaces (this includes glass, tile, and counter cleaners).

If any surface discoloring or rusting appears, clean it quickly with Bon-Ami® or Barkeepers Friend Cleanser® and a nonabrasive cloth. Always clean with the grain. Always finish with Claire® Stainless Steel Polish and Cleaner or comparable product to prevent further problems.

Using abrasive pads such as ScotchBrite™ will cause the graining in the stainless steel to become blurred.

Rust not cleaned up promptly can penetrate the surface of the stainless steel and complete removal of the rust may not be possible.

INTERIOR CLEANING

Disconnect power to the unit.

Clean the interior and all removed components using a mild nonabrasive detergent and warm solution applied with a soft sponge or non-abrasive cloth.

Rinse the interior using a soft sponge and clean water.

Do not use any solvent-based or abrasive cleaners. These types of cleaners may transfer taste and/or odor to the interior products and damage or discolor the interior.

DEFROSTING

Under normal conditions this unit does not require manual defrosting. Minor frost on the rear wall or visible through the evaporator plate vents is normal and will melt during each cycle.

If there is excessive build-up of 1/4" (6 mm) or more, manually defrost the unit.

Ensure the door is closing and sealing properly.

High ambient temperature and excessive humidity can also produce frost.



DO NOT use an ice pick or other sharp instrument to help speed up defrosting. These instruments can puncture the inner lining or damage the cooling unit. DO NOT use any type of heater to defrost. Using a heater to speed up defrosting can cause personal injury and damage to the inner lining.

QUICK START GUIDE

NOTICE

The drain pan was not designed to capture the water created when manually defrosting. To prevent water from overflowing the drain pan and possibly damaging water sensitive flooring, the unit must be removed from cabinetry.

To defrost:

1. Disconnect power to the unit.
2. Remove all products from the interior
3. Prop the door in an open position (2 in. [50 mm] minimum).
4. Allow the frost to melt naturally.
5. After the frost melts completely, clean the interior and all removed components.
6. When the interior is dry, reconnect power and turn unit on.

Cleaning the System

The system should be cleaned each time you change your coffee tank and before extended periods of non use using a solution of water and ULACOFFEECLEAN. One packet of ULACOFFEECLEAN (Stera-Sheen®) was included with your product and more can be purchased at u-line.com.

Notice

Confirm system is not pressurized by turning off nitrogen – turn handle clockwise. Release pressure in system by pulling up on the release valve.



Cleaning Solution Preparation

Follow safety instructions on packet. Mix ULACOFFEECLEAN with 2 gallons of warm (100°F/38°C) potable water.



Tap Heads

Clean the faucet with warm soapy water. Remove nose cone and soak in the cleaning solution for at least five minutes. Rinse with clean potable water, dry and reattach.



Infuser Filter

Disassemble by unscrewing the cap. Rinse cap and filter with warm potable water and reassemble.



Line and System Cleaning

1. Remove the contents, clean the keg with water warm soapy water, and rinse.
2. Pour the cleaning solution into keg, attach hoses and open the nitrogen valve to pressurize the system.
3. Place a bucket under the taps. Pull and hold the left tap open until approximately ½ gallon of cleaning solution is dispensed. Close the left faucet. Pull and hold the right faucet handle until ½ gallon of solution is dispensed. Discard solution.
4. Allow the cleaning solution to remain in the system for a minimum of five minutes.
5. Dispense approximately ¼ gallon of the solution through the left tap. Dispense the remaining solution from the right tap. No rinsing is required.
6. Unless refilling, remove lid from keg to allow keg to air dry.

U-Line Corporation (U-Line) Limited Warranty

One Year Limited Warranty

For one year from the date of original purchase, this warranty covers all parts and labor to repair or replace any part of the product that proves to be defective in materials or workmanship. For products installed and used for normal residential use, material cosmetic defects are included in this warranty, with coverage limited to 60 days from the date of original purchase. All service provided by U-Line under the above warranty must be performed by a U-Line factory authorized servicer, unless otherwise specified by U-Line. Service provided during normal business hours.

Two Year Limited Warranty (5 Class Product)

For two years from the date of original purchase, this warranty covers all parts and labor to repair or replace any part of the product that proves to be defective in materials or workmanship. For products installed and used for normal residential use, material cosmetic defects are included in this warranty, with coverage limited to 60 days from the date of original purchase. All service provided by U-Line under the above warranty must be performed by a U-Line factory authorized servicer, unless otherwise specified by U-Line. Service provided during normal business hours.

Available Second & Third Year Limited Warranty

In addition to the standard one and two year warranties outlined above, U-Line offers a one year extension of the warranties from the date of purchase, free of charge. To take advantage of this extension, you must register your product with U-Line within 60 days from the date of purchase at u-line.com and provide proof of purchase.

Five Year Sealed System Limited Warranty

For five years from the date of original purchase, U-Line will repair or replace the following parts, labor not included, that prove to be defective in materials or workmanship: compressor, condenser, evaporator, drier, and all connecting tubing. All service provided by U-Line under the above warranty must be performed by a U-Line factory authorized servicer, unless otherwise specified by U-Line. Service provided during normal business hours.

Terms

These warranties apply only to products installed in any one of the fifty states of the United States, the District of Columbia, or the ten provinces of Canada. The warranties do not cover any parts or labor to correct any defect caused by negligence, accident or improper use, maintenance, installation, service, repair, acts of God, fire, flood or other natural disasters. The product must be installed, operated, and maintained in accordance with your product's User Guide.

The remedies described above for each warranty are the only ones that U-Line will provide, either under these warranties or under any warranty arising by operation of law. U-Line will not be responsible for any consequential or incidental damages arising from the breach of these warranties or any other warranty, whether express, implied, or statutory. Some states do not allow the exclusion or limitation of incidental or consequential damages, so the above limitation or exclusion may not apply to you. These warranties give you specific legal rights, and you may also have other rights which vary from state to state.

Any warranty that may be implied in connection with your purchase or use of the product, including any warranty of *merchantability* or any warranty *fit for a particular purpose* is limited to the duration of these warranties, and only extends to five years in duration for the parts described in the section related to the five year limited warranty above. Some states do not allow limitations on how long an implied warranty lasts, so the above limitations may not apply to you.

- The warranties only apply to the original purchaser and are non-transferable.
- The second, third, and five year warranties cover products installed and used for normal residential or designated marine use only.
- The warranties apply to units operated outside only if designed for outdoor use by model and serial number.
- U-Line Commercial products are covered by the one year and 5 year limited warranties and are not eligible for the second and third year limited warranties.
- Replacement water filters, light bulbs, and other consumable parts are not covered by these warranties.
- The start of U-Line's obligation is limited to four years after the shipment date from U-Line.
- In-home instruction on how to use your product is not covered by these warranties.
- Food, beverage, and medicine loss are not covered by these warranties.
- If the product is located in an area where U-Line factory authorized service is not available, you may be responsible for a trip charge or you may be required to bring the product to a U-Line factory authorized service location at your own cost and expense.
- Units purchased after use as floor displays, and/or certified reconditioned units, are covered by the limited one year warranty only and no coverage is provided for cosmetic defects.
- Signal issues related to Wi-Fi connectivity are not covered by these warranties.

For parts and service assistance, or to find U-Line factory authorized service near you, contact U-Line:
8900 N. 55th Street, Milwaukee, WI 53223 • u-line.com • onlineservice@u-line.com • +1.800.779.2547