

Stainless Solid

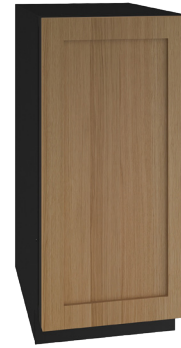

Integrated Solid

### Additional Options

- Accessory panels are designed for easy installation on Integrated models



Stainless Handleless Panel

### Key Features

- **Industry Exclusive: U-Choose™ feature allows you to select ice density**
- **Industry Leading: Produces up to 90 lb of ice per day**
- **Industry Leading: Stores 30 lb of ice**
- Makes cylindrical compressed ice bits approx. 3/4" L x 1/2" H
- Eco friendly - most efficient type of specialty ice
- Digital touch pad control with blue LED display
- Indicator alert notifies user when cleaning is needed
- Soft close door with articulating hinge
- Bright white LED lighting
- White interior
- Stainless steel handle (7/8" diameter)
- Easiest nugget ice machine cleaning process in the industry
- Free cleaning kit with product registration at u-line.com
- Integrated model requires 3/4" custom door panel and handle (not supplied by U-Line)
- Field reversible door is shipped right-hand hinged
- Built-in or freestanding
- Four adjustable leveling legs
- Factory installed drain pump model recommended if a gravity drain is not accessible

### Model Details

Model	Voltage/Hz	Door Swing	Pump	Finish	Shipping Weight
UHNB115-SS01B	115 / 60	Field Reversible	-	Stainless Solid	101 lb
UHNP115-SS01B	115 / 60	Field Reversible	Pump Included	Stainless Solid	106 lb
UHNB115-IS01B	115 / 60	Field Reversible	-	Integrated Solid	96 lb
UHNP115-IS01B	115 / 60	Field Reversible	Pump Included	Integrated Solid	100 lb

### Accessories

Model	Description	Finish	Shipping Weight
ULALINEFILTERHEAD	In-Line Water Filter Head 3/8" NPT (Required for initial setup)	N/A	1 lb
ULALINEFILTER	In-Line Water Filter (Standard)	N/A	4.5 lb
ULALINEFILTERL	In-Line Water Filter (Large)	N/A	7 lb
ULANUGGETCLEANKIT	Includes 1 Bottle Nugget Ice Cleaner, Funnel, & Hose	N/A	1 lb
ULANUGGETCLEAN	Nugget Ice Cleaner (Single 8 oz. bottle)	N/A	1 lb
ULAWATERHOOKUP	Braided Water Supply Line Kit	N/A	2 lb
ULASHP15SOLID*	Stainless Handleless Panel Solid	Stainless	6 lb

\*Installs on integrated models.

# HNB115 / HNP115 • 15" Nugget Ice • 1 Class

## Front

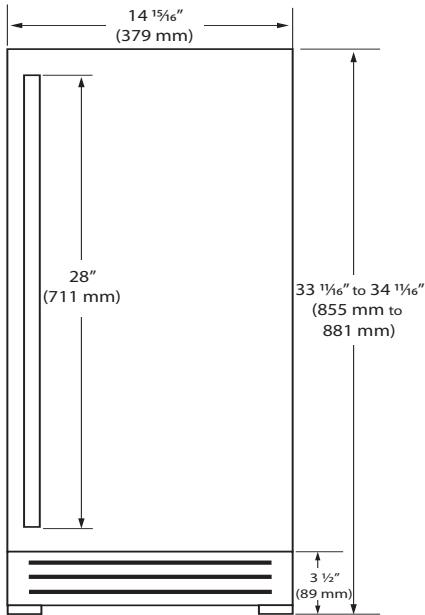

## Side

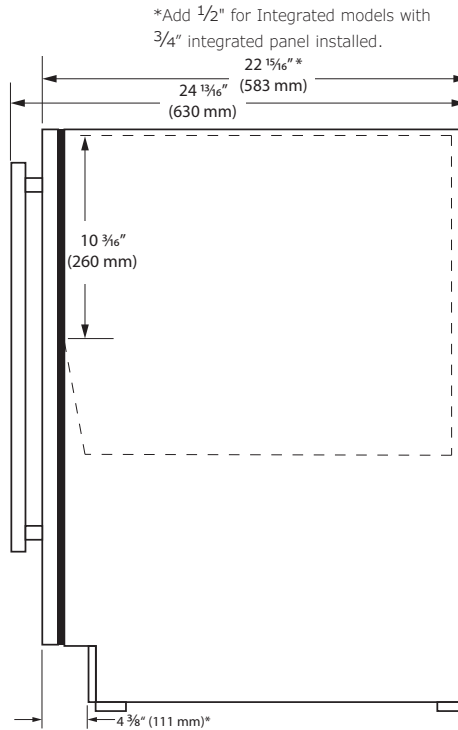

## Top

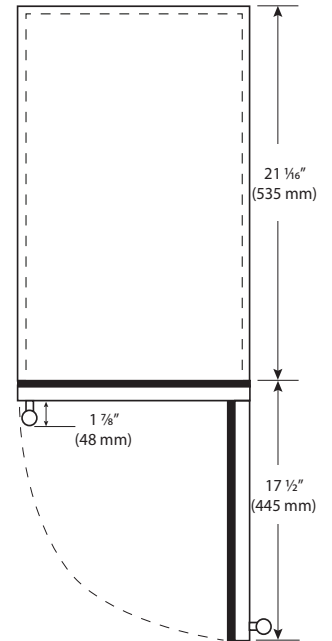

## Specifications

Model	HNB115 / HNP115
Amps: Running	3
Dimensions: Product Depth*	22 15/16" / 583 mm
Dimensions: Product Height	33 1/16" / 855 mm
Dimensions: Product Width	14 15/16" / 379 mm
ENERGY STAR	Yes
Ice Production Per Day	90 lb
Ice Storage	30 lb
Panel Height	30" / 762mm
Panel Thickness	3/4" 20mm
Panel Type	Solid Panel
Panel Width	14 15/16" / 379 mm
Product Weight: Max	106 lb
Refrigerant Type:	R600a (1.59 oz)
Sabbath (Star K Certified)	Yes

### Water Mineral Content Requirements:

- TDS: Greater than 5 ppm (mg/l) but less than 400 ppm (mg/l)
- Hardness: Less than 200 mg/l (12 gpg)

Not recommended for use with softened water

Visit [u-line.com/waterfilters](http://u-line.com/waterfilters) to learn about water quality solutions.

## Warranty

- 1 Year (parts & labor) / 5 year sealed system (parts)
- + **Additional 1 Year (parts & labor) warranty at no cost with product registration**

See complete warranty for details



## Back

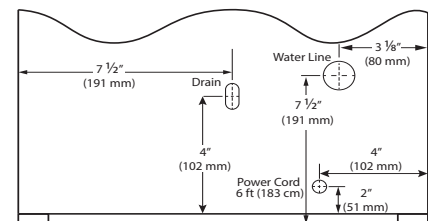

## Cabinet Cut-Out

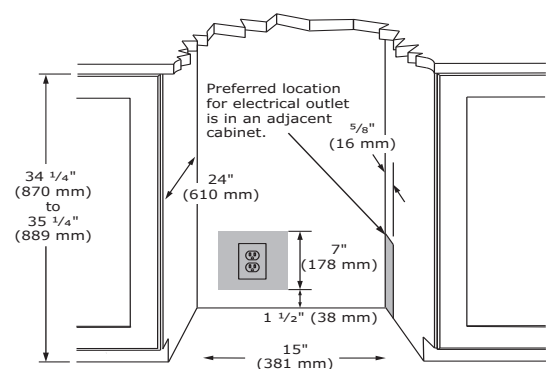

## Installation Notes

- No additional clearance is needed for ventilation
- Do not obstruct front grille air flow

Please visit [u-line.com](http://u-line.com) to view this model's User Guide & Service Manual. All Specifications are subject to change without notice.

8900 North 55th Street • Milwaukee, Wisconsin 53223 USA • +1.414.354.0300 • [sales@u-line.com](mailto:sales@u-line.com) • [u-line.com](http://u-line.com)