

USER GUIDE & SERVICE MANUAL



Model: UONB115-SS01B

USER GUIDE & SERVICE MANUAL

[Click on any section below to jump directly there](#)

Table of Contents

Intro

Safety

Safety and Warning

Disposal And Recycling

Installation

Environmental Requirements

Electrical

Cutout & Product Dimensions

Side by Side Installation

Water Hookup

Drain

Anti-Tip Bracket

General Installation

Grille Installation

Door Swing

Door Adjust

Maintenance

Cleaning

Cleaning Condenser

Extended Non-Use

Operating Instructions

First Use

Control Operation

Ice

Airflow and Product Loading

Service

Troubleshooting

Wire Diagram

Product Liability

Parts

R600a Specifications

System Diagnosis Guide

Compressor Specifications

Troubleshooting Extended

Control Operation - Service

Thermistor

Warranty

USER GUIDE

WELCOME TO U-LINE

Congratulations on your U-Line purchase. Your product comes from a company with over five decades of premium modular ice making, refrigeration, and wine preservation experience. U-Line continues to be the American leader, delivering versatility and flexibility for multiple applications including residential, light commercial, outdoor and marine use. U-Line's complete product collection includes Wine Captain® Models, Beverage Centers, Clear Ice Machines, Nugget Ice Machines, Crescent Ice Makers, Glass & Solid Door Refrigerators, Drawer Models, Freezers, Combo® Models, and more.

U-Line has captivated those with an appreciation for the finer things with exceptional functionality, style, inspired innovations, and attention to even the smallest details. We are known and respected for our unwavering dedication to product design, quality, and selection. U-Line is headquartered in Milwaukee, Wisconsin, and has shipped product to five continents for over two decades and is proud to have the opportunity to ship to you.

U-LINE — RIGHT PRODUCT. RIGHT PLACE. RIGHT TEMPERATURE®

PRODUCT INFORMATION

IMPORTANT - Before connecting your new Nugget Ice Machine, be sure to carefully follow all manufacturer recommendations throughout this guide regarding water quality. Please see WATER HOOKUP section for more information.

Looking for additional information on your product? User Guides, Spec Sheets, CAD Drawings, Compliance Documentation, and Product Warranty information are all available for reference and download at u-line.com.

PROPERTY DAMAGE / INJURY CONCERNS

In the unlikely event property damage or personal injury is suspected related to a U-Line product, please take the following steps:

1. U-Line Customer Care must be contacted immediately at +1.414.354.0300.
2. Service or repairs performed on the unit without prior written approval from U-Line is not permitted. If the unit has been altered or repaired in the field without prior written approval from U-Line, claims will not be eligible.

GENERAL INQUIRIES

U-Line Corporation
8900 N. 55th Street
Milwaukee, Wisconsin 53223 USA
Monday - Friday 8:00 am to 4:30 pm CST
T: +1.414.354.0300
Email: sales@u-line.com
u-line.com

SERVICE & PARTS ASSISTANCE

Monday - Friday 8:00 am to 4:30 pm CST
T: +1.414.354.0300
Service Email: onlineservice@u-line.com
Parts Email: onlineparts@u-line.com

CONNECT WITH US



Designed, engineered and assembled in WI, USA

Safety and Warning

NOTICE

Please read all instructions before installing, operating, or servicing the appliance.

Use this appliance for its intended purpose only and follow these general precautions with those listed throughout this guide:

SAFETY ALERT DEFINITIONS

Throughout this guide are safety items labeled with a Danger, Warning, or Caution based on the risk type:



Danger means that failure to follow this safety statement will result in severe personal injury or death.



Warning means that failure to follow this safety statement could result in serious personal injury or death.



Caution means that failure to follow this safety statement may result in minor or moderate personal injury, property, or equipment damage.



This unit contains R600a (Isobutane) which is a flammable hydrocarbon. It is safe for regular use. Do not use sharp objects to expedite defrosting. Do not service without consulting the “R600a specifications” section included in the User Guide. Do not damage the refrigerant circuit.



Service must be done by factory authorized service personnel. Any parts shall be replaced with like components. Failure to comply could increase the risk of possible ignition due to incorrect parts or improper service.

CALIFORNIA PROPOSITION 65

This product contains chemicals known to the state of California to cause cancer and birth defects or other reproductive harm.

www.P65warnings.CA.gov



This equipment is to be installed with adequate backflow protection to comply with applicable federal, state and local codes.

Disposal and Recycling



RISK OF CHILD ENTRAPMENT. Before you throw away your old refrigerator or freezer, take off the doors and leave shelves in place so children may not easily climb inside.

If the unit is being removed from service for disposal, check and obey all federal, state, and local regulations regarding the disposal and recycling of refrigeration appliances, and follow these steps completely:

1. Remove all consumable contents from the unit.
2. Unplug the electrical cord from its socket.
3. Remove the door(s)/drawer(s).

Environmental Requirements

This unit is designed to operate between 50°F (10°C) and 100°F (38°C). Higher ambient temperatures may reduce the unit's ability to reach low temperatures and/or reduce ice production on applicable models.

For best performance, keep the unit out of direct sunlight and away from heat generating equipment.

In climates where high humidity and dew points are present, condensation may appear on outside surfaces. This is considered normal. The condensation will evaporate when the humidity drops.



Damages caused by ambient temperatures of 40°F (4°C) or below are not covered by the warranty.

Electrical



SHOCK HAZARD — Electrical Grounding Required. Never attempt to repair or perform maintenance on the unit until the electricity has been disconnected.

Never remove the round grounding prong from the plug and never use a two-prong grounding adapter.

Altering, cutting or removing power cord, removing power plug, or direct wiring can cause serious injury, fire, loss of property and/or life, and will void the warranty.

Never use an extension cord to connect power to the unit.

Always keep your working area dry.

NOTICE

Electrical installation must observe all state and local codes. This unit requires connection to a grounded (three-prong), polarized receptacle that has been placed by a qualified electrician.

The unit requires a grounded and polarized 115 VAC, 60 Hz, 15A power supply (normal household current). An individual, properly grounded branch circuit or circuit breaker is recommended. A GFCI (ground fault circuit interrupter) is usually not required for fixed location appliances and is not recommended for your unit because it could be prone to nuisance tripping. However, be sure to consult your local codes.

See CUTOUT & PRODUCT DIMENSIONS for recommended receptacle location.

USER GUIDE

Cutout & Product Dimensions

PREPARE SITE

Your U-Line product has been designed for either free-standing or built-in installation. When built-in, your unit does not require additional air space for top, sides, or rear. However, the front grille must NOT be obstructed, and clearance is required for an electrical connection in the rear.



Unit can NOT be installed behind a closed cabinet door.

If you would like to align the face of the unit with other adjacent cabinet doors, you may need to alter the wall just behind the drain connection on the unit to accommodate the drain.

CUTOUT DIMENSIONS

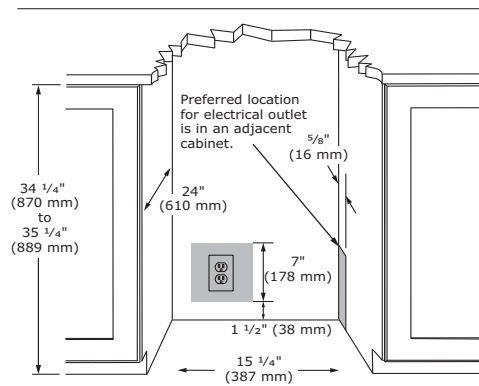

*15\" cutout width sufficient if door protrudes beyond adjacent cabinetry

PRODUCT DIMENSIONS

REAR

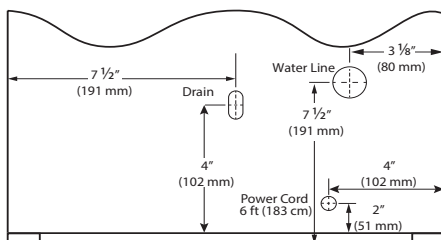

FRONT

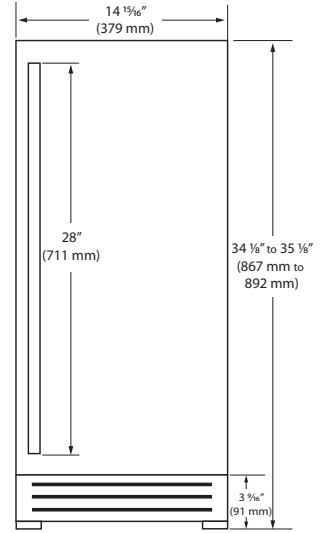

TOP

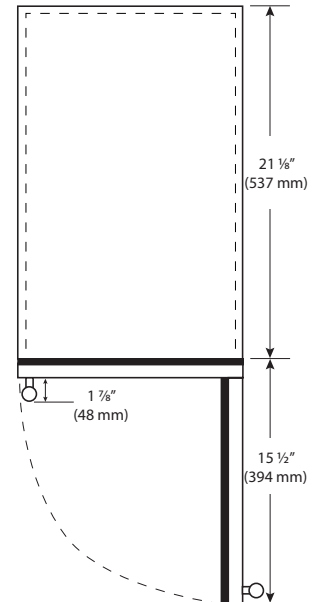

SIDE

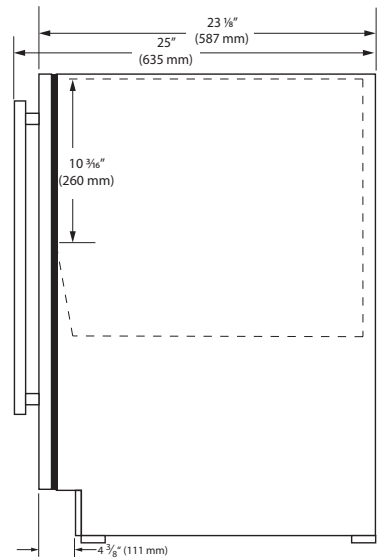

Side-by-Side Installation

Two units may be installed side-by-side.

Cutout width for a side-by-side installation is the cutout dimension of a single unit times two.

No trim kit is required. However, 1/4" (6 mm) of space needs to be maintained between the units to ensure unobstructed door swing.

Units must operate from separate, properly grounded electrical receptacles placed according to each unit's electrical specifications requirements.

Side-by-Side Installation with Bracket

1. Slide both units out so screws on top of units are easily accessible.
2. Remove screws as shown below.



3. Place bracket over holes and attach to unit with two screws removed in step 2 using a T-25 Torx driver. Tighten screws fully.
4. Gently push units into position. Be careful not to entangle the electrical cord or water line, if applicable.
5. Re-check the leveling, from front to back and side to side. Make any necessary adjustments. The unit's top surface should be approximately 1/8" (3 mm) below the countertop.

Water Hookup

⚠ CAUTION

TO PREVENT DAMAGE TO YOUR ICE MACHINE AND/OR VOID YOUR WARRANTY, FOLLOW ALL WATER SUPPLY GUIDELINES AS LISTED BELOW.

PREPARE PLUMBING

The water valve uses a standard 1/4" (6.35 mm) compression fitting. U-Line recommends using accessory water hook up kit – part # 80-54674-00. The kit includes a 10' (3 m) braided flexible water supply line and a brass hose fitting.

⚠ CAUTION

Plumbing installation must observe all state and local codes. All water and drain connections MUST BE made by a licensed/qualified plumbing contractor. Failure to follow recommendations and instructions may result in damage and/or harm.

Water Supply

When connecting the water supply, please note the following:

- Water Mineral Content must meet the following:
 - TDS: less than 200 ppm (mg/l)
 - Hardness: Less than 200 mg/l (12 gpg)
- **Water supply MUST NOT be from a water softener.**
- A TDS meter is included with your unit
- Water Treatment Options
 - TDS level of 200 ppm or higher and/or a hardness of 12-19 gpg can be treated by U-Line's in-line water filter accessories available at u-line.com or your local dealer:
 - ULALINEFILTER — Standard
 - ULALINEFILTERL — Large
 - ULALINEFILTERHEAD — 3/8" NPT, initial setup requires head & filter
 - Use bypass level 6

Measure Water TDS

Every Nugget Ice Machine comes with a TDS meter similar to the one below. The TDS meter measures the **Total Dissolved Solids** level that exists in the water supply; this is measured in ppm (parts per million).

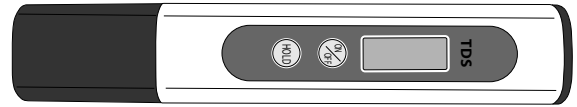

⚠ WARNING

The TDS meter does not test the toxicity of the water and is not to be used to determine potability. A TDS METER CANNOT DETECT THE TOXINS THAT MAKE WATER UNSAFE TO DRINK.

1. Turn on sink faucet and let run for 30 seconds.
2. Fill a clean glass (2 inches of water is sufficient).
3. Remove cap from meter.
4. Turn on meter and immerse meter into the water.

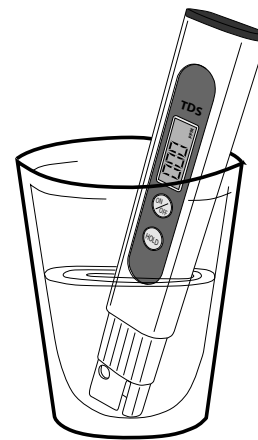

5. Leave meter immersed for 30 seconds.
6. Remove meter and check the readout for the TDS level in ppm - to save the reading, press the hold button.

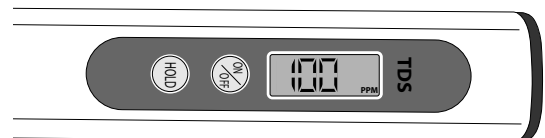

7. Turn off meter, dry off, and replace cap.

USER GUIDE

Based upon the TDS measurement, see the below table to determine the correct filter required to protect the ice machine.

Water Quality	1-3 Users	4+ Users
200 TDS and/or 12 gpg hardness or less	Required for extended warranty Standard Filter Change 1x per year	Required for extended warranty Large Filter Change 1x per year
201-400 TDS and/or 12-19 gpg hardness	Required Large Filter Change 1x per year	Required Large Filter Change 2x per year
400+ TDS, and/or 20+ gpg hardness	Contact your local water quality professional prior to installation	

- The water pressure should be between 20 and 120 psi (138 and 827 kPa).
- The water line MUST have a shut-off valve in the supply line.
- The water line should be looped into 2 coils. This will allow the unit to be removed for cleaning and servicing. Make certain that the tubing is not pinched or damaged during installation.

CAUTION

Do not use any plastic water supply line. The line is under pressure at all times. Plastic may crack or rupture with age and cause damage to your home.

Do not use tape or joint compound when attaching a braided flexible water supply line that includes a rubber gasket. The gasket provides an adequate seal – other materials could cause blockage of the valve.

Failure to follow recommendations and instructions may result in damage and/or harm, flooding or void the product warranty.

Use new hose set. Do not reuse old hose set.

CAUTION

Turn off water supply and disconnect electrical supply to unit prior to installation.

Use caution when handling back panel. The edges could be sharp.

HOOKUP WATER

1. Turn off water supply and disconnect electrical supply to product prior to attempting installation.
2. Remove the back panel.
3. Thread water line through back panel hole (with bushing).
4. Locate water valve inlet and connect to valve.

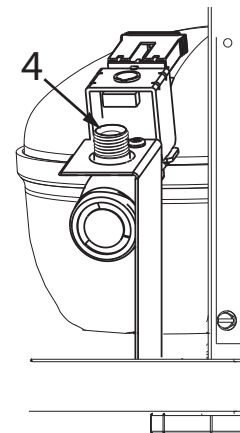
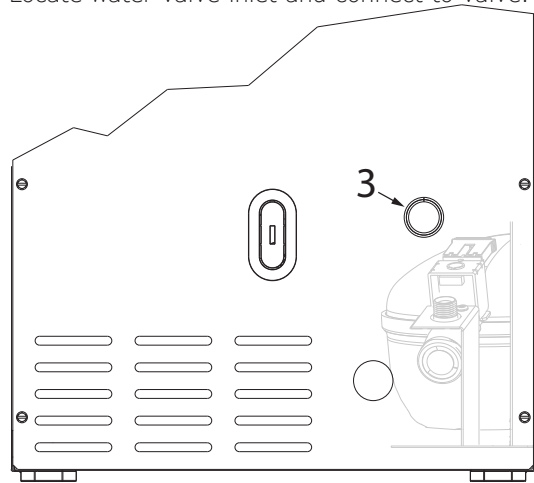

5. Turn on water supply and check for leaks.
6. Reinstall back panel.

Drain

Model numbers including "CL" or "NB" do not include a factory installed drain pump.

Model numbers including "CP" or "NP" include a factory installed drain pump.

DRAIN CONNECTION



If your U-Line unit did not come with a factory installed drain pump you must use a gravity style drain connection. For assistance in determining if your unit has a pump please contact U-Line. The floor drain must be large enough to accommodate drainage from all attached drains. Follow these guidelines when installing drain lines to prevent water from flowing back into the ice maker storage bin and/or potentially flowing onto the floor, which may result in personal injury or property damage

NOTICE

Drain can NOT be located directly below the unit. Unit has a solid base that will not allow the unit to drain below itself.

There is a possibility that hose connections may have loosened during shipment.

Verify all connections and fittings are free from leaks.



This equipment is to be installed with adequate backflow protection to comply with applicable federal, state and local codes

GRAVITY DRAIN

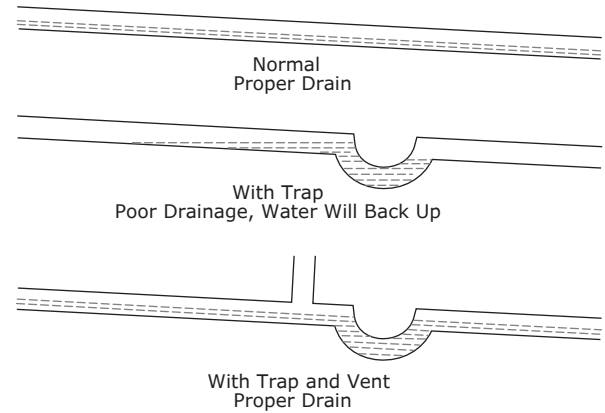

A gravity drain may be used if:

Drain line has at least a 1" drop per 48" (approximately 2 cm drop per 100 cm) of run.

Drain line does not create traps and is vented per local code.

1. Cut the pre-installed drain tube to length.
2. Connect to your local plumbing per the local code.
3. If necessary, insulate drain line to prevent condensation.



Failure to connect water supply or drain line connections properly can result in personal injury and property damage. Gravity drain connections must be routed downward from the rest of the unit at the rate of 1/4" per foot (1 cm per 50 cm).

USER GUIDE

FACTORY INSTALLED DRAIN PUMP

If your drain line will run up to a stand pipe, disposal or spigot assembly, or does not otherwise meet the requirements for a gravity drain, you may have ordered a factory installed drain pump.

If you need to install a drain pump into your unit, see DRAIN PUMP section in the User Manual.

To order a drain pump, order part number 80-54147-00 online at u-line.com.

See below for typical installations requiring a drain pump.

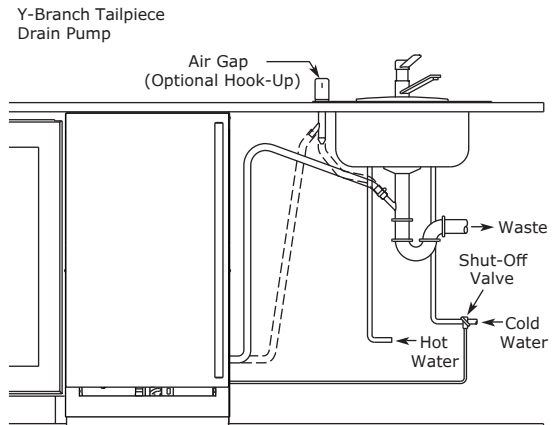

NOTICE

The maximum lift for the drain pump is 10 feet. This must be done as close to the rear of the unit as possible.

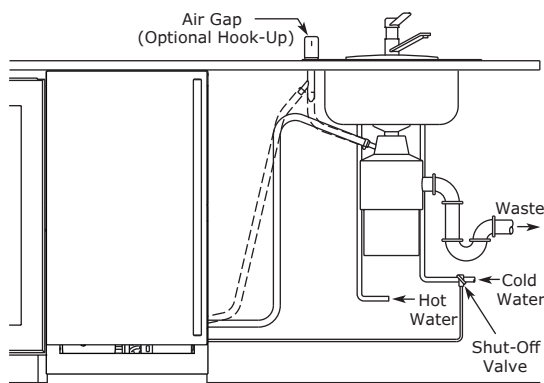
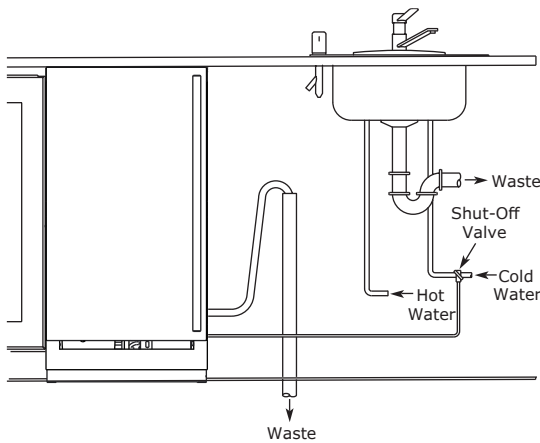

Anti-Tip Bracket

1. Slide unit out so screws on top of unit are easily accessible.
2. Remove the two screws from the opposite side of the hinge assembly using a T-25 Torx driver (see below).

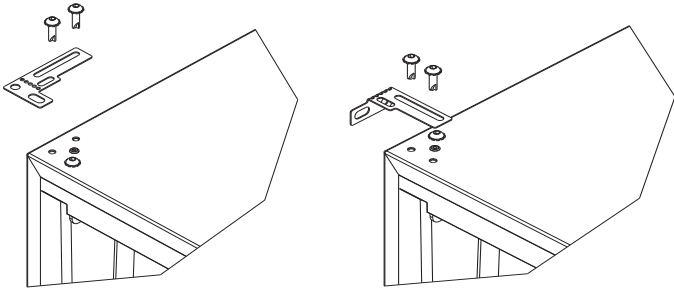

3. Place bracket over holes and attach to unit with two screws removed in step 2 using a T-25 Torx driver. Tighten screws fully.
4. Gently push unit into position. Be careful not to entangle the electrical cord or water line, if applicable.
5. Check to be sure the unit is level from front to back and side to side. Make any necessary adjustments. The unit's top surface should be approximately $\frac{1}{8}$ " (3 mm) below the countertop.
6. Secure bracket into adjoining surface.

General Installation

LEVELING INFORMATION

1. Use a level to confirm the unit is level. Level should be placed along top edge and side edge as shown.

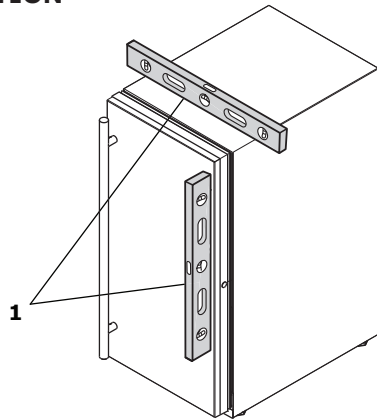

2. If the unit is not level, adjust the legs on the corners of the unit as necessary.



3. Confirm the unit is level after each adjustment and repeat the previous steps as needed.

INSTALLATION TIP

If the room floor is higher than the floor in the cutout opening, adjust the rear legs to achieve a total unit rear height of $\frac{1}{8}$ " (3 mm) less than opening's rear height. Shorten the unit height in the front by adjusting the front legs. This allows the unit to be gently tipped into the opening. Readjust the front legs to level the unit after it is correctly positioned in the opening.

INSTALLATION

1. Plug in the power/electrical cord.
2. Gently push the unit into position. Be careful not to entangle the cord or water and drain lines, if applicable.
3. Re-check the leveling, from front to back and side to side. Make any necessary adjustments. The unit's top surface should be approximately $\frac{1}{8}$ " (3 mm) below the countertop.
4. Install the anti-tip bracket.
5. Remove interior packing material and wipe out the inside of the unit with a clean, water-dampened cloth.

Grille Installation

REMOVING AND INSTALLING GRILLE



Disconnect electric power to the unit before removing the grille.

When using the unit, the grille must be installed.



DO NOT touch the condenser fins. The condenser fins are SHARP and can be easily damaged.

Removing the grille

1. Disconnect power to the unit.
2. Loosen the two screws (1).
3. Remove grille (2) from unit.

Installing the grille

1. Align cabinet and grille holes and secure, but do not over tighten grille screws (1).
2. Reconnect power to the unit.

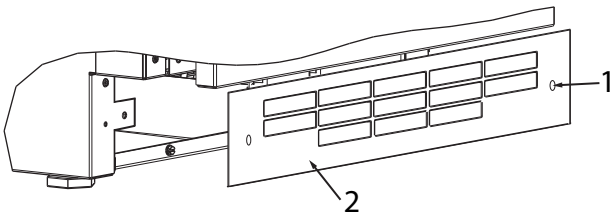

Door Swing

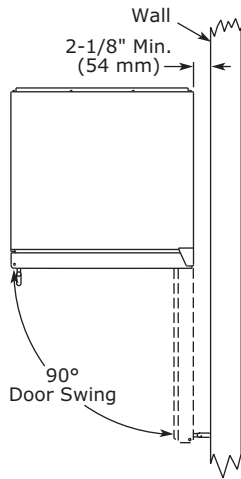

Units have a zero clearance for the door to open 90°, when installed adjacent to cabinets.

Stainless Steel models require 2-1/8" (54 mm) door clearance to accommodate the handle if installed next to a wall.

Door Adjustments

HINGE COVER

Hinge cover included with the literature bag is optional.

To install hinge cover:

1. Press hinge cover squarely over hinge.

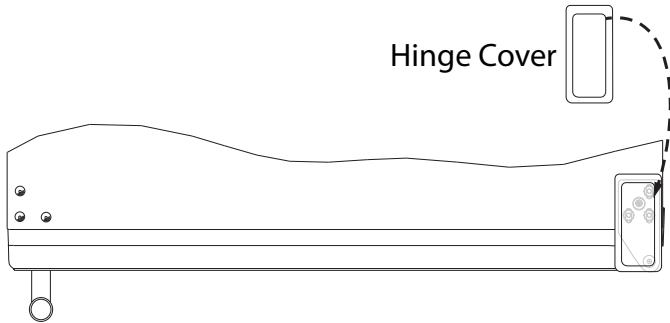

DOOR ALIGNMENT AND ADJUSTMENT

Align and adjust the door if it is not level or is not sealing properly. If the door is not sealed, the unit may not cool properly, or excessive frost may form in the interior.

NOTICE

Properly aligned, the door's gasket should be firmly in contact with the cabinet all the way around the door (no gaps). Carefully examine the door's gasket to ensure that it is firmly in contact with the cabinet. Also make sure the door gasket is not pinched on the hinge side of the door.

To align and adjust the door:

1. Gently pry off hinge cover from top of unit.
2. Loosen (do not remove) top and bottom hinge screws using a Torx T-25 screwdriver on the top and a 1/4" socket on the bottom.
3. Align door squarely with cabinet.
4. Make sure gasket is firmly in contact with cabinet all the way around the door (no gaps).
5. Tighten bottom hinge screws.
6. Tighten top hinge screws and replace hinge cover.

REVERSING THE DOOR

Location of the unit may make it desirable to mount the door on the opposite side of the cabinet.

The hinge hardware will be removed and reinstalled on the opposite side of the cabinet.

TO REVERSE THE DOOR

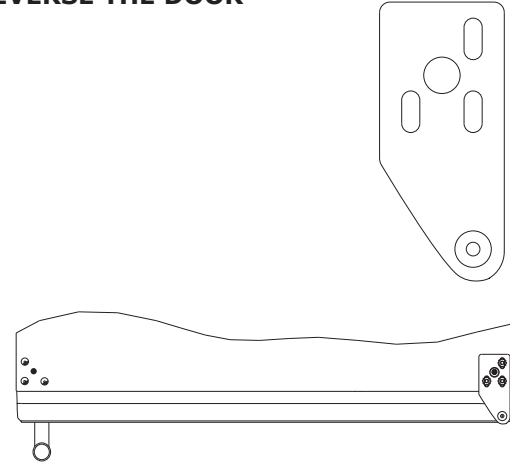

Remove arrow clips:

1. With a puddy knife or other flat tool, gently pry each arrow clip from hinge mounting holes.
2. Set aside arrow clips to be reused on the opposite side.

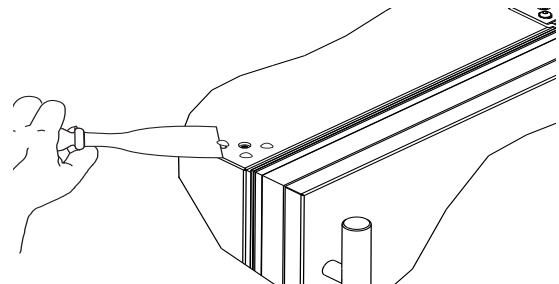

Remove top hinge and door:

1. Remove hinge cover from top of unit
2. Hold door to keep it from falling.
3. Remove top hinge from cabinet using a Torx T-25 screwdriver to remove three screws.

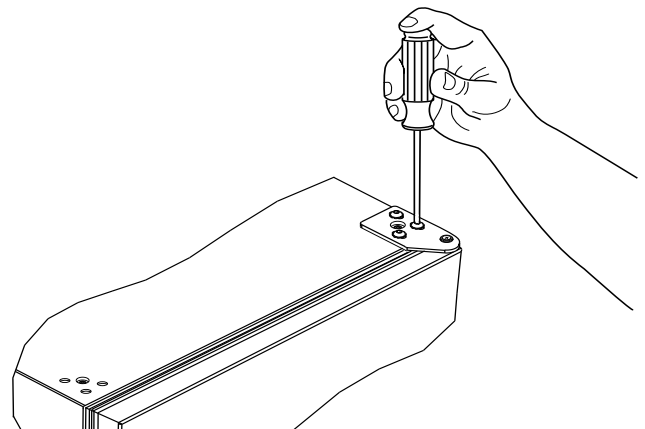

USER GUIDE

- Remove door by tilting forward and lifting door off bottom hinge. Retain shoulder washers; they will be reused.
- Insert arrow clips into holes

Remove bottom hinge:

- Remove bottom hinge from cabinet using a T-25 TORX screw driver to remove three screws.
- Remove corresponding screws on opposite side of cabinet. On some models there may be a nut behind one or both screws on either side.

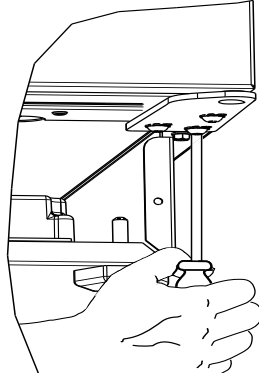

Install bottom hinge:

Install three screws. Replace nuts if used.

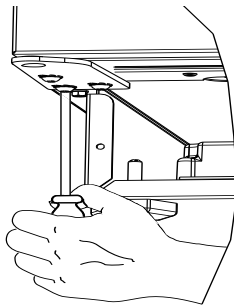

PREPARE DOOR FOR RE-INSTALLATION

Rotate gasket

- With a flat tool, such as a putty knife, gently pry up beneath the gasket and spacer until it is completely free from the door surface.

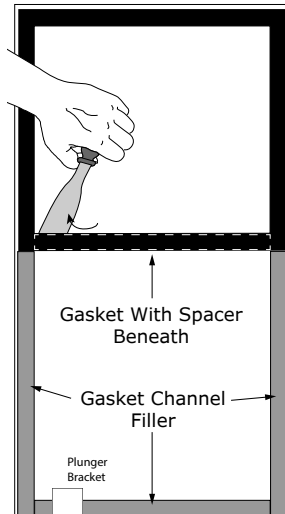

- Remove the rest of the gasket, by grabbing hold and gently pulling gasket from gasket channel.

- Remove the 3 pieces of gasket channel filler and set aside to be used on the opposite end.
- Remove 2 screws holding plunger bracket. Reinstall plunger bracket in the gasket channel on opposite corner of door. Fasten bracket using same 2 screws in the pre-drilled holes.

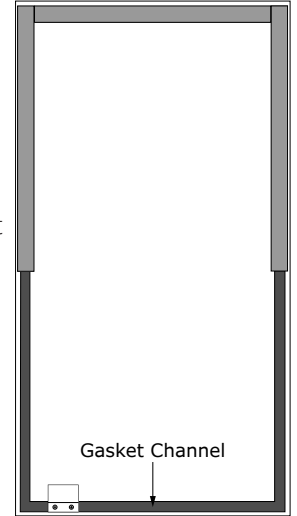
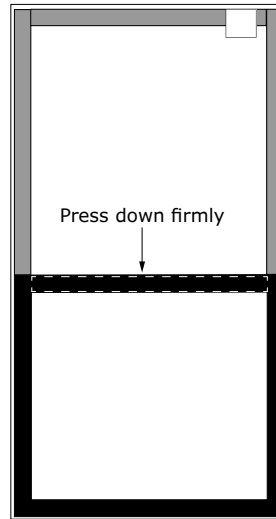

- Install 3 pieces of gasket channel filler into the gasket channel, pressing in firmly.
- Install gasket into channel, beginning at one corner and pressing in firmly.

Note: It may be necessary to apply a strip of two-sided tape for a firm adhesion.

- Press down on middle horizontal portion of gasket until it adheres to the door surface.

Install top hinge and door:

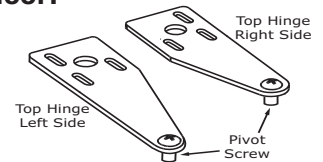

- Remove pivot screw from hinge, flip hinge over, and install the pivot screw in the same hole from the opposite surface.
- Lift the door onto the bottom hinge.
- Align edge of the hinge with the outer edge of the unit.
- Tighten three screws and replace hinge cover.
- Replace hinge cover.

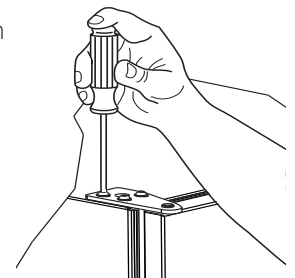

Align and adjust the door:



Align and adjust the door (see DOOR ALIGNMENT AND ADJUSTMENT)

First Use

Initial startup requires no adjustments. See CONTROL OPERATION section for more details.

NOTICE

Discard the ice produced during the first two or three hours of operation to avoid possible dirt or scale that may dislodge from the water line.

When plugged in, the unit will begin operating under the factory default settings. If the unit was turned off during installation, simply press  and the unit will immediately switch on. To turn the unit off, press  and release.

Control Operation

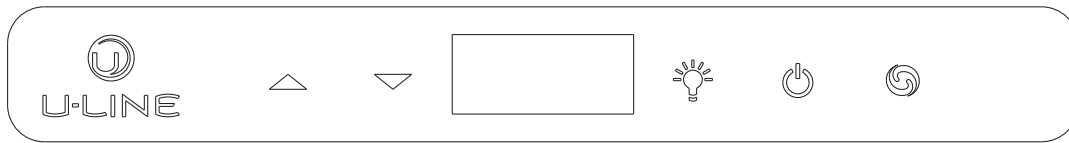

CONTROL FUNCTION GUIDE

FUNCTION	COMMAND	NOTES
ON/OFF	Press and release	Unit will immediately turn On or OFF
Adjust ice density	See "Ice" section	
Enable Sabbath Mode	Press and hold for 5 seconds and release	The °F / °C symbol will flash briefly after 5 seconds. Interior light and display will go dark and remain so until user resets mode - unit continues to operate
Disable Sabbath Mode	Press and release	Display and interior light return to normal operation
Clean Mode	See "Cleaning" section	
Showroom Mode	Hold and for 5 seconds	The °F / °C symbol will flash. Display will be lit and interior light will function. Unit will not cool. Repeat command to return to normal operation

This unit is Star-K certified. See www.star-k.org for more details.

DOOR ALERT NOTIFICATION

When the door is left open for more than 30 minutes:

- Ice production will cease
- A tone will sound for several seconds every minute
- will appear in display

Close door to silence alert and reset (Ice production will resume if bin sensor is not satisfied)





Ice

The Nugget Ice Machine produces cylindrical bits of compressed ice approximately $\frac{3}{4}$ " x $\frac{1}{2}$ ".

Ice is produced until the machine senses the bin is full. As ice slowly melts in the bin, the level of ice drops and ice production resumes. This ensures a constant supply of fresh ice is always available.

The factory default ice setting is 0, which produces a firm and compact ice nugget. U-Line's exclusive U-Choose™ ice adjustability feature allows you five levels of adjustment from 0 to -5. At -5 the ice is soft and chewable.

To adjust the ice density:

1. Hold  for 5 seconds - display will flash current ice setting
2. Adjust using  or 
3. Confirm setting by pressing 

Airflow and Product Loading

NOTICE

The unit requires proper airflow to perform at its highest efficiency. Do not block the front grille at any time, or the unit will not perform as expected. Do not install the unit behind a door.

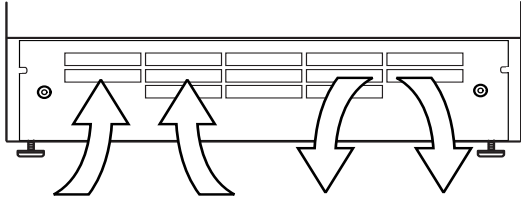

Cleaning

EXTERIOR CLEANING

Vinyl Clad (Black or White) Models

Clean surfaces with a mild detergent and warm water solution. Do not use solvent-based or abrasive cleaners. Use a soft sponge and rinse with clean water. Wipe with a soft, clean towel to prevent water spotting.

Clean any glass surfaces with a non-chlorine glass cleaner.

Stainless Models

Stainless door panels, handles and frames can discolor when exposed to chlorine gas, pool chemicals, saltwater or cleaners with bleach.

Keep your stainless unit looking new by cleaning with a good quality all-in-one stainless steel cleaner and polish monthly. For best results use Claire® Stainless Steel Polish and Cleaner. Comparable products are acceptable. Frequent cleaning will remove surface contamination that could lead to rust. Some installations may require cleaning weekly.

Do not clean with steel wool pads.

Do not use stainless steel cleaners or polishes on any glass surfaces.

Clean any glass surfaces with a non-chlorine glass cleaner.

Do not use cleaners not specifically intended for stainless steel on stainless steel surfaces (this includes glass, tile, and counter cleaners).

If any surface discoloring or rusting appears, clean it quickly with Bon-Ami® or Barkeepers Friend Cleanser® and a nonabrasive cloth. Always clean with the grain. Always finish with Claire® Stainless Steel Polish and Cleaner or comparable product to prevent further problems.

Using abrasive pads such as ScotchBrite™ will cause the graining in the stainless steel to become blurred.

Rust not cleaned up promptly can penetrate the surface of the stainless steel and complete removal of the rust may not be possible.

For information on Keg and Tap Towers, please reference the Single and Double Tap Tower Kits User Guide on u-line.com.

Integrated Models

To clean integrated panels, use household cleaner per the cabinet manufacturer's recommendations.

INTERIOR CLEANING



Disconnect power to the unit.

Clean the interior and all removed components using a mild nonabrasive detergent and warm solution applied with a soft sponge or non-abrasive cloth.

Rinse the interior using a soft sponge and clean water.

Do not use any solvent-based or abrasive cleaners. These types of cleaners may transfer taste and/or odor to the interior products and damage or discolor the interior.

NUGGET ICE MACHINE CLEANING CYCLE

This ice machine has an automatic clean alert function. The control will indicate  in the display, reminding you to clean your unit. When  is displayed, ice production will continue. Depending on water conditions, more frequent cleaning may be necessary: see chart below. Cleaning removes lime scale, other mineral deposits, and sanitizes the machine. Poor ice quality and reduced ice output are signs that cleaning is necessary.



BEFORE RUNNING THE CLEANING CYCLE, MEASURE THE TDS (TOTAL DISSOLVED SOLIDS) LEVEL OF YOUR WATER SUPPLY.

(See WATER HOOKUP section in this guide to find instructions for using the TDS meter that was included with this ice machine.)

TDS (Total Dissolved Solids) (ppm)	Cleaning Interval
5 - 150 ppm	6 months
150 - 200 ppm	4 months

Replacement TDS meter may be ordered at u-line.com

Part # 80-55672-00

Under normal conditions cleaning should be done when the display shows $\square L$. You may initiate a cleaning cycle at any time by pressing and holding the clean button for 10 seconds. $\square I$ will appear in the display indicating the start of the cleaning process.

Failure to clean may reduce the quality and quantity of ice produced. Once the clean cycle begins, it can be canceled by pressing ⏻ three times. Press ⏻ once more to start making ice. The clean cycle will automatically cancel if user fails to activate control at steps 2, 3b, and 5b within 2 hours.

Required for cleaning:

- Clean potable water
- Bucket and cleaning sponge
- Internal water filter (if applicable) — ULANUGGETFILTER**
- SafeCLEAN Plus™ Cleaner — ULANUGGETCLEAN**
- Hose (7/16" ID x 9/16" OD) and funnel
 - Register your product at u-line.com and receive a free cleaning kit - ULANUGGETCLEANKIT** (cleaner, hose, & funnel)

** available for purchase at u-line.com or your local dealer

Need more cleaner? Visit u-line.com



Use only SafeCLEAN Plus™ Cleaner. Use of any other cleaner may damage the finish of the evaporator and will void the warranty.

Follow safety and handling instructions printed on the SafeCLEAN Plus™ bottle.

Notice:

Select models include a water filter. The filter must remain in place when using and cleaning the machine. The filter is designed to filter out scale, sediment, particles and cloudiness as well as reduce chlorine and other off tastes and odors. U-Line recommends replacing the filter (Part No. ULANUGGETFILTER) when you clean your machine. The filter is available at u-line.com.

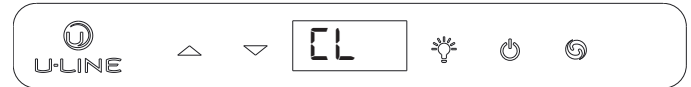

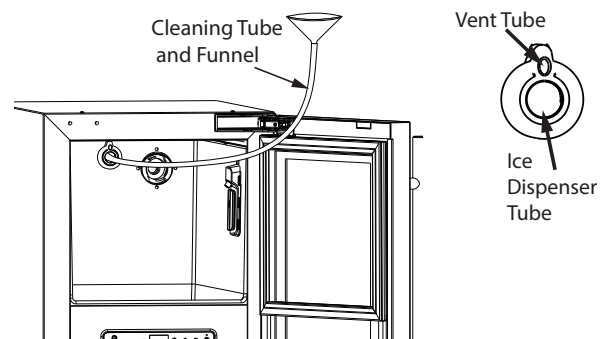

1. Press and Hold ⏻ for 10 seconds
 - a. $\square I$ will appear in the display
 - b. Remove access shield
 - c. Remove all ice in bin
 - d. Remove any ice protruding from the ice dispenser tube.
2. Insert the end of the cleaning tube into the ice dispenser; slowly pour in approximately 1 quart of hot (min. 100° F) potable water. This will melt ice inside the dispenser tube. It is normal for some water to flow from the ice dispenser tube and exit from the vent tube while pouring. Omit this step if no ice is in the ice dispenser tube.

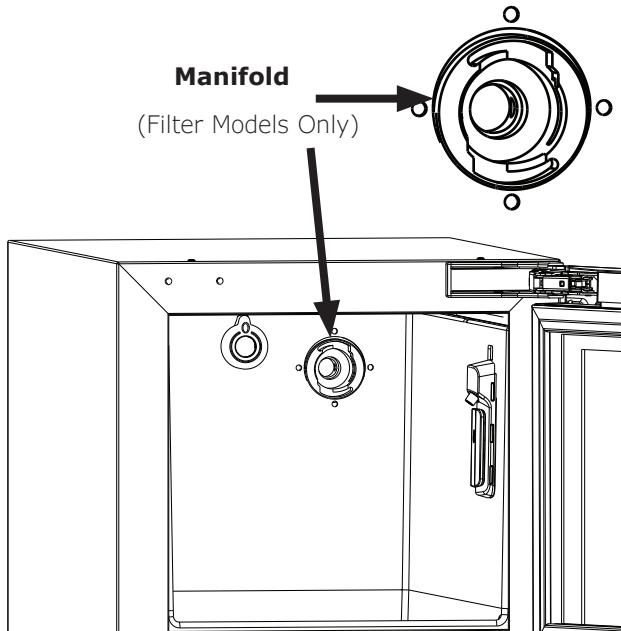

3. Press and release ⏻
 - a. $\square 2$ will appear in the display
 - b. Mix 4 ounces of SafeCLEAN Plus™ with 2 quarts of potable water.
4. Wait until $\square 3$ appears in the display
 - a. Using the funnel and cleaning tube, slowly pour 3/4 of the cleaning solution into the dispenser tube. Air and some water will exit the vent tube. Remove cleaning tube. (Optional - for deeper cleaning, allow solution to soak for 60 minutes)
 - b. Press and release ⏻
5. $\square 4$ will appear in the display
 - a. The machine will circulate the solution, cleaning and sanitizing the internal components, for approximately 20 minutes.
 - b. While the machine is circulating the cleaning solution, use 1/2 of the remaining cleaning solution and a sponge to wipe down the inside of the ice bin and scoop. Rinse with clean potable water.

6. When **05** appears in the display, 3 soft tones will sound, indicating the cleaning phase is complete
 - a. Remove and discard water filter if applicable by rotating $\frac{1}{4}$ turn counterclockwise.
 - b. Use the remaining cleaning solution to wipe the manifold and surrounding area. Rinse with clean potable water.



- c. Using the hose and funnel, slowly pour 1.5 quarts (48 oz.) of clean potable water into the ice dispenser tube. Air and some water will exit the vent tube.
 - d. Install new water filter. Press and rotate $\frac{1}{4}$ turn clockwise
 - e. Press and release 
7. **06** will appear in the display
 - a. Reinstall shield and close door.
 - b. The machine will circulate water and perform a series of final rinses for approximately 15 minutes.
 - c. The unit will resume making ice - indicated by 3 soft tones and **ICE** scrolling in the display.
 - . uop[Discard first 10 minutes of ice production.

Cleaning Condenser

INTERVAL - EVERY SIX MONTHS

To maintain operational efficiency, keep the front grille free of dust and lint, and clean the condenser when necessary. Depending on environmental conditions, more or less frequent cleaning may be necessary.

⚠ WARNING

Disconnect electric power to the unit before cleaning the condenser.

NOTICE

DO NOT use any type of cleaner on the condenser unit. Condenser may be cleaned using a vacuum, soft brush, or compressed air.

1. Remove the grille. See GRILLE INSTALLATION).
2. Clean the condenser coil using a soft brush or vacuum cleaner.
3. Install the grille.

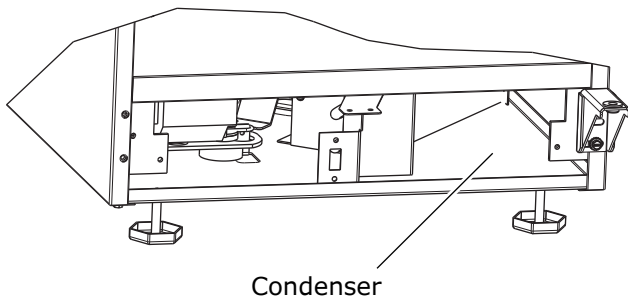

Extended Non-Use

VACATION/HOLIDAY, PROLONGED SHUTDOWN

The following steps are recommended for periods of extended non-use:

1. Remove all consumable content from the unit.
2. Disconnect the power cord from its outlet/socket and leave it disconnected until the unit is returned to service.
3. Turn off the water supply.
4. If ice is on the evaporator, allow ice to thaw naturally.
5. Clean and dry the interior of the cabinet. Ensure all water has been removed from the unit.
6. Disconnect the water and drain line (if applicable) making sure all water is removed from the lines.
7. The door must remain open to prevent formation of mold and mildew. Open door a minimum of 2" (50 mm) to provide the necessary ventilation.

WINTERIZATION

If the unit will be exposed to temperatures of 40°F (5° C) or less, the steps above must be followed. In addition, drain pumps in clear ice machines must be drained according to the following procedure:

1. Remove the drain pump from the ice machine.
2. Drain the water in the pump's reservoir by turning the pump upside down and allowing the water to drain through the pump's inlet and vent tube fittings.
3. After water is drained, reinstall the drain pump and reattach all connections.

For questions regarding winterization, please call U-Line at 414.354.0300.



Damage caused by freezing temperatures is not covered by the warranty.

Do not put anti-freeze in your unit.

Troubleshooting

BEFORE CALLING FOR SERVICE

If you think your U-Line product is malfunctioning, read the CONTROL OPERATION section to clearly understand the function of the control.

If the problem persists, read the NORMAL OPERATING SOUNDS and TROUBLESHOOTING GUIDE sections below to help you quickly identify common problems and possible causes and remedies. Most often, this will resolve the problem without the need to call for service.

If your product needs service, please go to www.U-Line.com and navigate to the Find a Servicer page to locate a U-Line Authorized servicer. If your product is in warranty please make sure to register it at www.U-Line.com/u-lineregistration. If you have any issues following this process you can contact the U-Line Corporation by phone at +1.414.354.0300

If you call, you will need your product Model and Serial Numbers. This information appears on the Model and Serial number plate located on the interior of your product, most often placed on the ceiling.

NORMAL OPERATING SOUNDS

All models incorporate rigid foam insulated cabinets to provide high thermal efficiency and maximum sound reduction for its internal working components. Despite this technology, your model may make sounds that are unfamiliar.

Normal operating sounds may be more noticeable because of the unit's environment. Hard surfaces such as cabinets, wood, vinyl or tiled floors and paneled walls have a tendency to reflect normal appliance operating noises.

Listed below are common refrigeration components with a brief description of the normal operating sounds they make. NOTE: Your product may not contain all the components listed.

- Compressor: The compressor makes a hum or pulsing sound that may be heard when it operates.

- Evaporator: Refrigerant flowing through an evaporator may sound like boiling liquid.
- Condenser Fan: Air moving through a condenser may be heard.
- Running Water: As your unit continues to produce ice you will hear water flowing into the collection chambers and running through the evaporator.

TROUBLESHOOTING GUIDE



ELECTROCUTION HAZARD. Never attempt to repair or perform maintenance on the unit before disconnecting the main electrical power.

Troubleshooting - What to check when problems occur:

Problem	Possible Cause and Remedy
Unit Does Not Operate. Electronic Display Blank.	No electrical supply. Plug unit in or check circuit breaker.
Display Showing Error Code.	If display shows error "dr", check to make sure door is sealing correctly. Make sure to close door completely. If sealing the door does not clear the error, contact U-Line service for more information.
Unit Develops Condensation on External Surfaces.	The unit is exposed to excessive humidity. Moisture will dissipate as humidity levels decrease.
Poor Ice Quality.	Unit may not be level. Check if unit is level. Ice maker system may be dirty. Clean the ice maker.
No Ice Production.	Ensure water is being supplied to the unit. Verify the ice making unit is turned on.
Not Enough Ice.	Ensure the condenser coil is clean and free of any dirt or lint build-up.
Water in Ice Bin.	Drain may be restricted, ensure drain is free of foreign debris.

Wire Diagram

42379_B

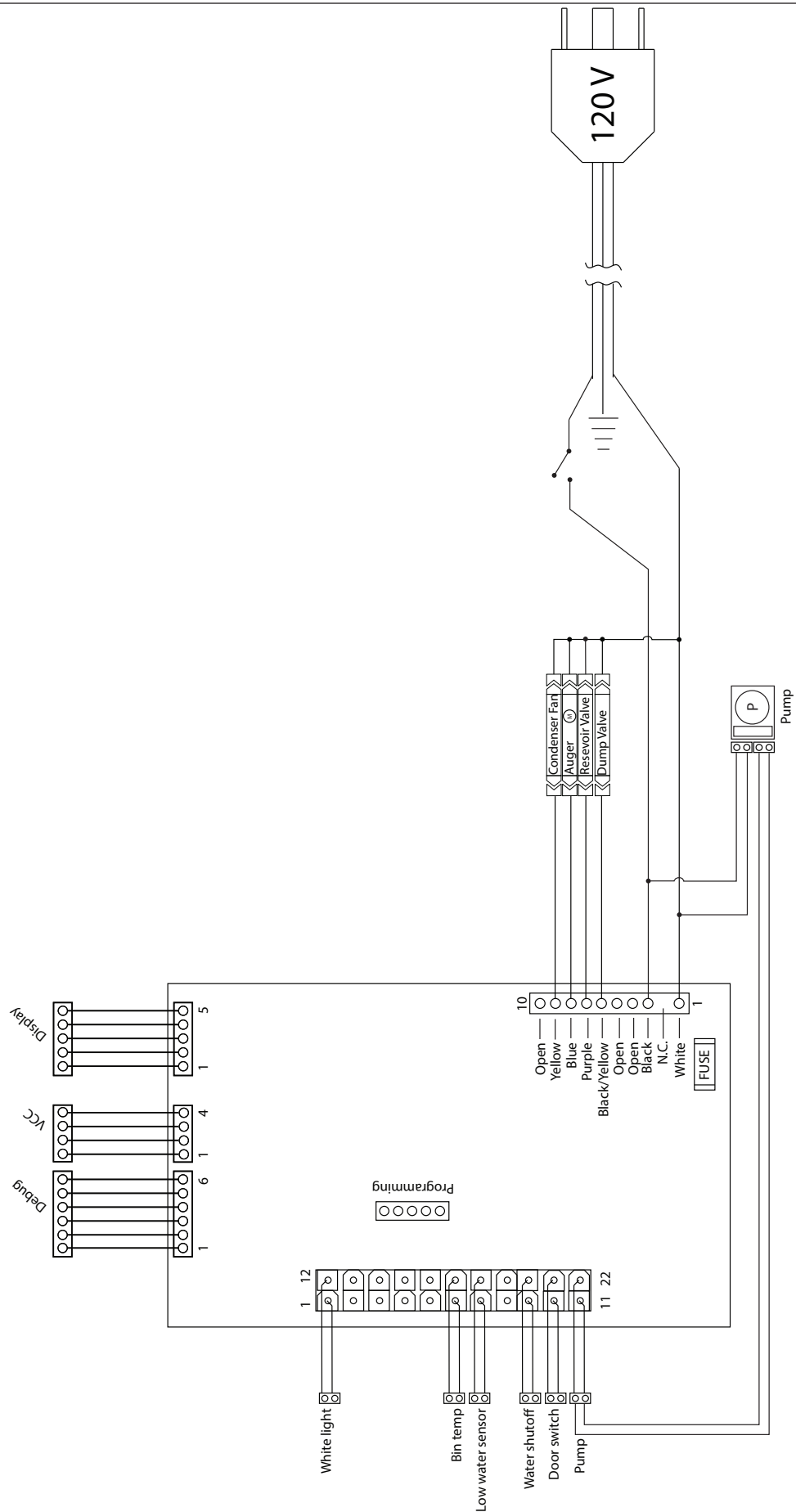

Product Liability

Field service technicians are authorized to make an initial assessment in the event of reported damages. If there are any questions about the process involved, the technician should call U-Line for further explanation.

While inspecting for defects or installation issues, photos should be taken to document any damages or issues found.

During the assessment, if the service technician is able to find the source of the damage and it can be resolved by replacement of a part, the servicer is authorized to replace the part in question. The part that caused the damage must be returned to U-Line in its entirety. The part must be clearly labeled with the serial number of the unit it was removed from, the date, and the servicer who removed the part.

If the service technician determines the damage is the result of installation issues (water connection/drain, etc.), the consumer would be notified and the issues shall be resolved at the direction of the consumer.

If damage is evident and the service technician is unable to find the source, U-Line must be contacted at +1.414.354.0300 for further direction.

8900 N. 55th Street • Milwaukee, WI 53223

T: +1.414.354.0300 • F: +1.414.354.5696

Website: www.u-line.com

**Right product. Right place.
Right temperature Since 1962.**

USER GUIDE

Parts

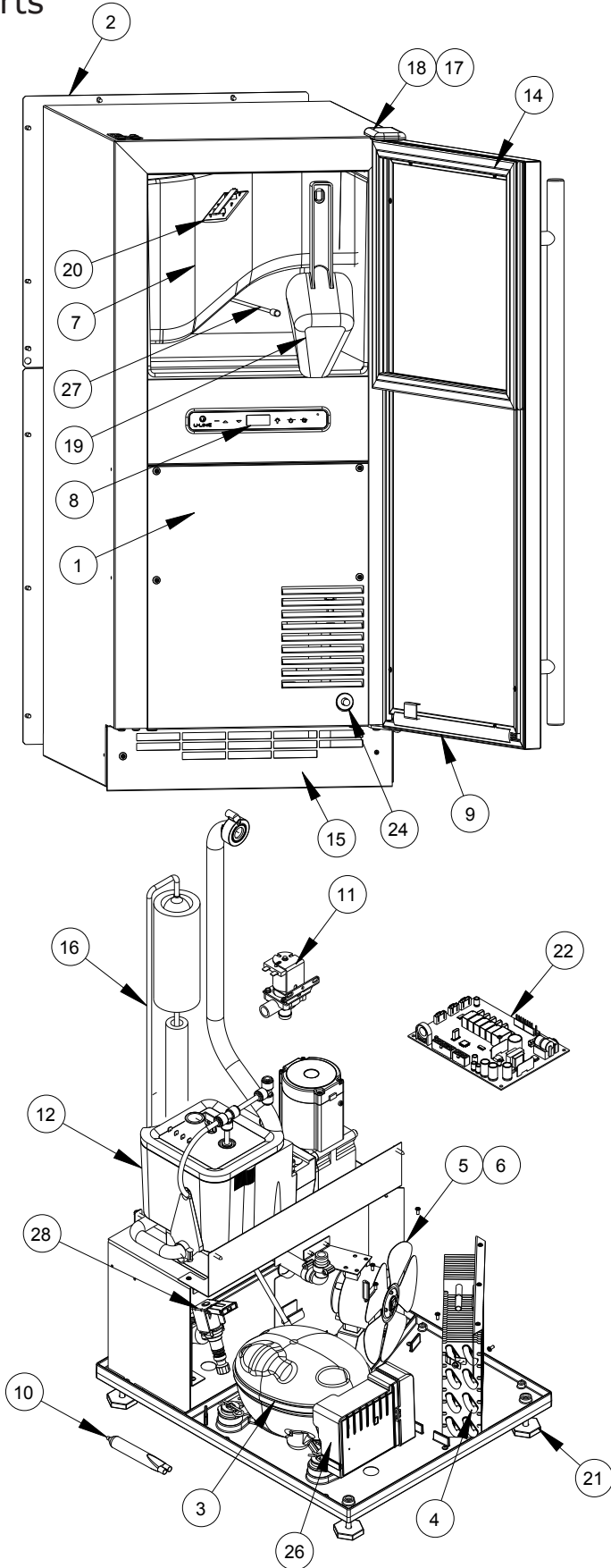

UONB115-SS01B

1	ACCESS PANEL	80-55385-00
2	BACK PANEL	80-55377-00
3	COMPRESSOR ASSEMBLY	80-55211-00
4	CONDENSER ASSEMBLY	80-55379-00
5	CONDENSER FAN BLADE	80-54066-00
6	CONDENSER FAN MOTOR	80-54138-00
7	COVER W/HOOK	80-54332-00
8	DISPLAY MODULE	80-55214-00
9	DOOR ASSEMBLY, OUTDOOR	80-55386-00
10	DRIER	80-54055-00
11	DUMP VALVE ASSEMBLY	80-55232-00
12	EVAPORATOR ASSEMBLY**	80-55216-00
13	FLOAT SWITCH*	80-55538-00
14	GASKET, DOOR	80-55396-00
15	GRILLE ASSY NUGGET	80-55389-00
16	HEAT EXCHANGER ASSEMBLY	80-55434-00
17	HINGE ASSEMBLY	80-55390-00
18	HINGE COVER	80-55499-00
19	ICE SCOOP	80-54080-00
20	LED LIGHT STRIP AND COVER	80-54000-00
21	LEG LEVELERS (4)	80-54019-00
22	MAIN BOARD	80-55398-00
23	PACKAGING*	80-54238-00
24	PLUNGER SWITCH NUG OUTDR	80-55391-00
25	POWER CORD, NUGGET*	80-55399-00
26	SERIAL INVERTER	80-55570-00
27	THERMISTOR	80-54006-00
28	WATER VALVE, RESERVOIR/INLET	80-55448-00
29	WIRE HARNESS, BOARD*	80-55226-00

*Not Pictured

**See next page for parts breakdown

Parts

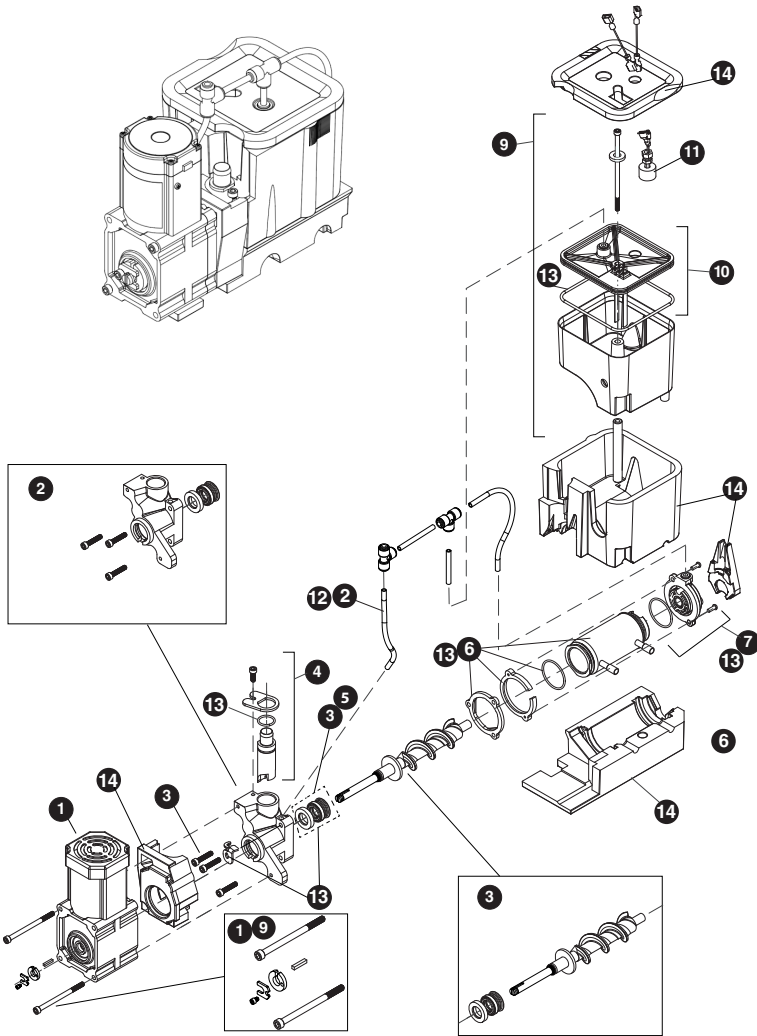

NUGGET ICE EVAPORATOR		
1	GEAR MOTOR ASSEMBLY	80-55371-01
2	MAIN HOUSING W/SEAL & SCREWS	80-55371-02
3	AUGER W/FRONT SEAL	80-55371-04
4	ICE COMPRESSION NOZZLE ASSY	80-55371-05
5	FRONT SEAL AND O-RING	80-55371-06
6	EVAPORATOR W/FLANGES & O-RING	80-55371-07
7	HOUSING, BUSHING	80-55371-08
8	HARDWARE KIT, GEAR MOTOR	80-55371-09
9	RESERVOIR & FLOAT COMPLETE ASSY	80-55371-10
10	RESERVOIR LID & O-RING	80-55371-11
11	FLOAT SWITCH	80-55538-00
12	WATER LINE, 12" SEGMENT	80-54722-01
13	WATER SEAL KIT	80-55371-13
14	INSULATION KIT*	80-55371-14
15	DUMP VALVE TUBE ASSY	80-55447-01
16	RESERVOIR DUMP VALVE TUBE ASSY	80-55371-20
17	ICE TRANSPORT TUBE ASSY	80-55371-19

*Insulation foam pieces are sold only as a complete set

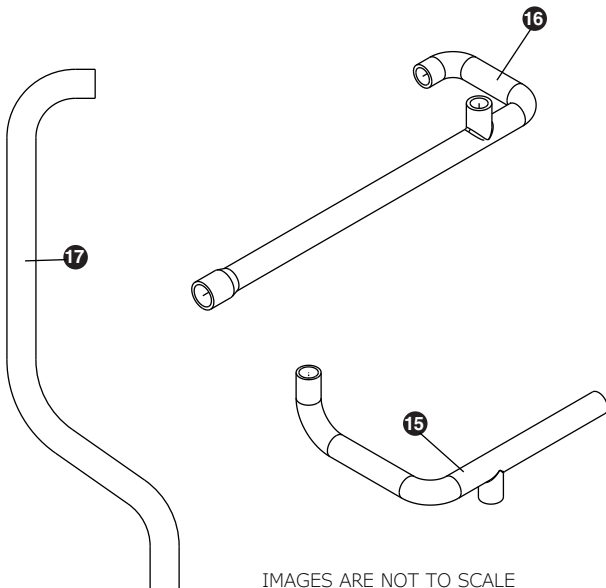

IMAGES ARE NOT TO SCALE

R-600A Specifications

For R-600a refrigerant service tips and more videos, go to: www.u-line.com/videos.

WARNING

Flammability warnings for a pure-iso-butane refrigerant.



Gloves and Eye Protection must be used.



R-600a is considered non-toxic, but is flammable when mixed with air.

Keep a dry powder type fire extinguisher in the work area.



R-600a is heavier than air, do not allow any leakage/migration to low areas such as basements and stairs.

Never use a torch on a fully charged refrigeration system.

Never substitute U-Line OEM replacement parts or methods of construction.

R-600a must be stored and transported in approved containers.

WARNING

Only skilled and well trained service technicians permitted to service R-600a equipped products.

All tools and equipment must be approved for use with R-600a refrigerant.

Local, state and federal laws, standards must be observed along with proper certification and licensing.

Ventilation is required during servicing.

No conversions to R-600a from any other refrigerants. OEM R-600a equipped unit only.

Service area must be free of ignition sources.

No smoking is allowed in the service area.

All replacement electrical components must be OEM and installed properly (sealed and covered).

If the evaporator is cold prior to service, it must be thawed prior to service.

When using a vacuum pump, start pump before opening refrigeration system.

Vacuum pump and recovery equipment should be at least 10 feet from the work area.

It is recommended that a simple LPG gas detector is on site during service.

Ensure that all R-600a is removed from the system prior to brazing any part of the sealed system.

Only a clean, dry leak free system should be charged with R-600a.

R-600A SPECIFICATIONS/LABELING

R-600a equipped products are labeled (both the unit and the compressor).

R-600a is colorless and odorless.

R-600a is considered non-toxic, but is flammable when mixed with air.

Do not remove or alter any R-600a labeling on the product.

Use only a refrigerant grade R-600a from a properly labeled container.

RECOVERING/RECLAIMING R-600A

(R-600a has been exempted from recovery/reclaiming requirements by the US EPA)

Recovery/Reclaiming equipment must be approved for use with R-600a.

Ensure the evaporator is at room temperature prior to recovery/reclaiming R-600a.

Use a common piercing pliers or piercing valve to remove R-600a from the compressor process tube. (Note: Piercing devices must not be left on the system and must be replaced with a Schrader type valve.)

USER GUIDE

Evacuate/reclaim via the piecing pliers to ensure the system is empty of R-600a before any system work is performed.



The recovery cylinder must be evacuated (no air inside) prior to accepting R-600a.

The recovery cylinder must not be filled more than 45% safe fill level and refrigerants must not be mixed.

The recovery cylinder must be clearly marked with R-600a and Flammable Warning labels.

Ensure proper ventilation during recovery/reclaiming of R-600a.

Start vacuum pump/recovery pump prior to piercing the compressor process tube.

Follow recovery/reclaim OEM instructions for the specific equipment used.

SYSTEM REPAIR

Ensure no residual R-600a refrigerant is left within the system prior to repair (simple venting is not sufficient).

Evacuate and charge with dry nitrogen for leak checks.

Repair leaks or replace system parts as required.

When re-brazing, the system must be purged with dry nitrogen and at least one access point open to the atmosphere.

When re-brazing, proper ventilation is required along with constant monitoring for the presence of R600a refrigerant.

The filter dryer must be replaced any time the sealed system is serviced.

No system should be open to the atmosphere for longer than 15 minutes to avoid moisture migration into the system components.

LEAK DETECTION

After removal of the R-600a, the unit can be charged with dry nitrogen or helium.

Electronic leak detection or soap solution can be used to check for nitrogen/helium leaks.



Never use a halide torch or lighted match to check the system for leaks at any time.

The high side of the refrigeration system (compressor discharge to outlet of drier) must be leak tested with the compressor running.

USER GUIDE

The low side of the refrigeration system (evaporator, compressor and suction line) must be leak tested with the compressor off (equalized pressure).

RECHARGING

No air is ever to be allowed inside the refrigeration system (R-600a refrigerant or dry nitrogen only).

Never use a torch on a fully charged refrigeration system.

Install a Schrader Type access port on the compressor process stub.



Evacuate the system to 100 microns prior to charging.

Weigh in the R-600a charge using a refrigerant scale. (run compressor an extra two minutes to clear the charging hoses).

Seal the Schrader Type access port, a proper cap and seal must be used to close the system.



SUMMARY

Safely handling R-600a requires proper procedures and training.

R-600a approved service tools must be used.

R-600a labeling must not be removed or altered.

Proper ventilation during service is required.

Never apply a torch to a charged R-600a refrigeration system.

Use OEM replacement service parts and do not alter the construction of the unit.

System Diagnosis Guide

REGRIGERATION SYSTEM DIAGNOSIS GUIDE

System Condition	Suction Pressure	Suction Line	Compressor Discharge	Condenser	Capillary Tube	Evaporator	Wattage
Normal	Normal	Slightly below room temperature	Very hot	Very hot	Warm	Cold	Normal
Overcharge	Higher than normal	Very cold may frost heavily	Slightly warm to hot	Hot to warm	Cool	Cold	Higher than normal
Undercharge	Lower than normal	Warm-near room temperature	Hot	Warm	Warm	Extremely cold near inlet - Outlet below room temperature	Lower than normal
Partial Restriction	Somewhat lower than normal vacuum	Warm-near room temperature	Very hot	Top passes warm - Lower passes cool (near room temperature) due to liquid	Room temperature (cool) or colder	Extremely cold near inlet - Outlet below room temperature backing up	Lower than normal
Complete Restriction	In deep vacuum	Room temperature (cool)	Room temperature (cool)	Room temperature (cool)	Room temperature (cool)	No refrigeration	Lower than normal
No Gas	0 PSIG to 25"	Room temperature (cool)	Cool to hot	Room temperature (cool)	Room temperature (cool)	No refrigeration	Lower than normal

Refrigeration Schematic

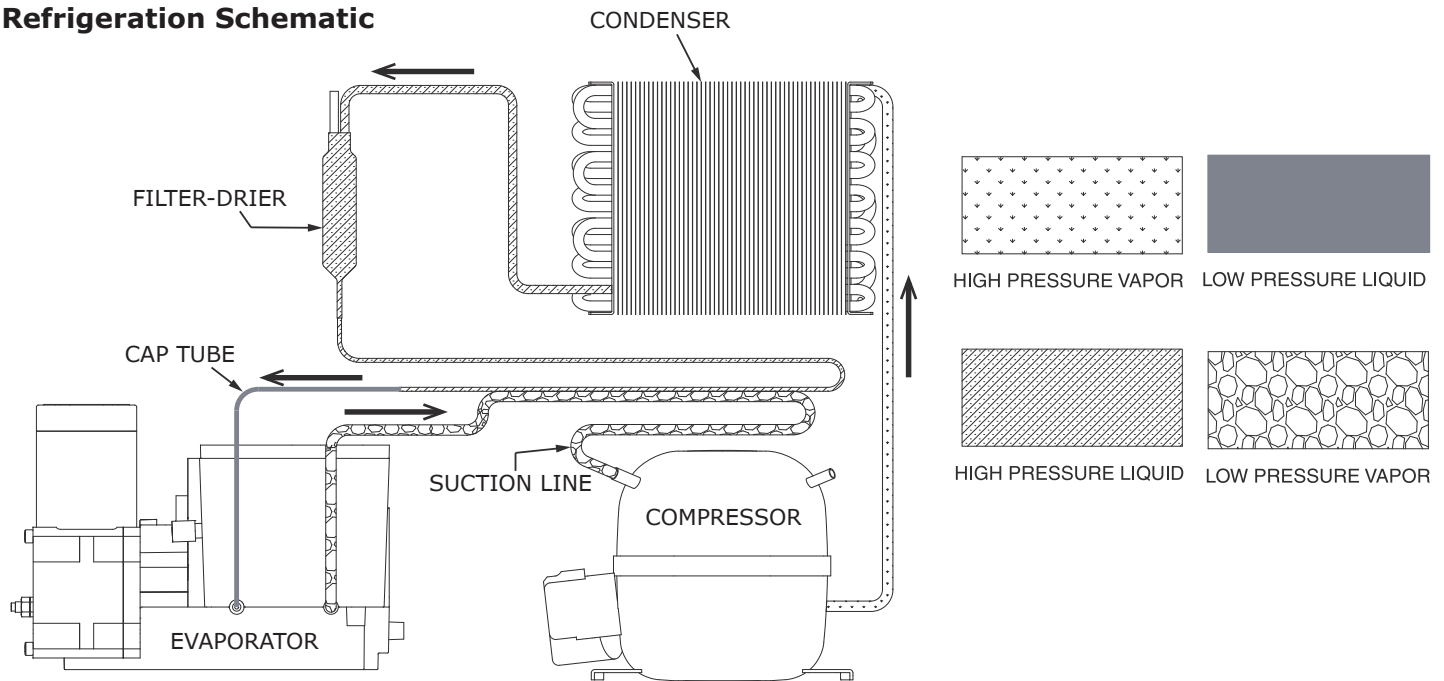

Compressor Specifications



Electrocution can cause death or serious injury. Burns from hot or cold surfaces can cause serious injury. Take precautions when servicing this unit.

Disconnect the power source.

Do not stand in standing water when working around electrical appliances.

Make sure the surfaces you touch are not hot or frozen.

Do not touch a bare circuit board unless you are wearing an anti-static wrist strap that is grounded to an electrical ground or grounded water pipe.

Handle circuit boards carefully and avoid touching components.

	FMXA9C
REFRIGERANT	R600A
VOLTAGE	230 VAC
FREQUENCY	43-134 Hz
START WINDING	20 Ohm at 77° F
RUN WINDING	20 Ohm at 77° F
RUN TO START	20 Ohm at 77° F
LRA	1.7 A
FLA	1.7 A
STARTING DEVICE	Inverter CF02C05
OVERLOAD	Inverter CF02C05

*All resistance readings are $\pm 10\%$

Troubleshooting - Extended



Never attempt to repair or perform maintenance on the unit until the main electrical power has been disconnected from the unit.

SPECIFIC ERRORS AND ISSUES

The advanced diagnostic capabilities of the electronic controls utilized on this unit allows for easy and thorough troubleshooting.

Navigation of the control is the key and is explained in the CONTROL OPERATION section of the manual, along with control button layout, control function descriptions, a service mode menu and service menu selection explanations.

Verification of temperature and thermistor performance can be identified by directly viewing thermistor readings in the service mode.

Component failure issues can be identified through service mode menu #20, "Component Testing." Individual components can be switched on and off to check for both proper function of a specific component and also delivery of supply voltage to the components through the relays and DC outputs located on the relay/power board.

Included in this section are some diagnostic tips and of course, if additional help is required, please contact the U-Line Corp, "Customer Care Facility" at +1.414.354.0300 for assistance.

NORMAL OPERATING SOUNDS

All models incorporate rigid foam insulated cabinets to provide high thermal efficiency and maximum sound reduction for its internal working components. Despite this technology, your model may make sounds that are unfamiliar.

Normal operating sounds may be more noticeable because of the unit's environment. Hard surfaces such as cabinets, wood, vinyl or tiled floors and paneled walls have a tendency to reflect normal appliance operating noises.

Listed below are common refrigeration components with a brief description of the normal sounds they make. NOTE: Your product may not contain all the components listed.

- Compressor: The compressor makes a hum or pulsing sound that may be heard when it operates.
- Evaporator: Refrigerant flowing through an evaporator may sound like boiling liquid.
- Condenser Fan: Air moving through a condenser may be heard.

Solenoid Valves: An occasional clicking sound may be heard as solenoid valves are operated.

USER GUIDE

MAIN CONTROL

The main control board is very robust and is rarely the cause of system issues. It is important to fully diagnose the board for any suspected failures before attempting to remove the board for replacement or service. Follow the guidelines below to fully test and diagnose the main control.

Power Fault

If the unit does not (or seems to not) power on, follow the flow chart below to help diagnose the issue. Before beginning it is important to first verify the unit is not simply set to sabbath mode.

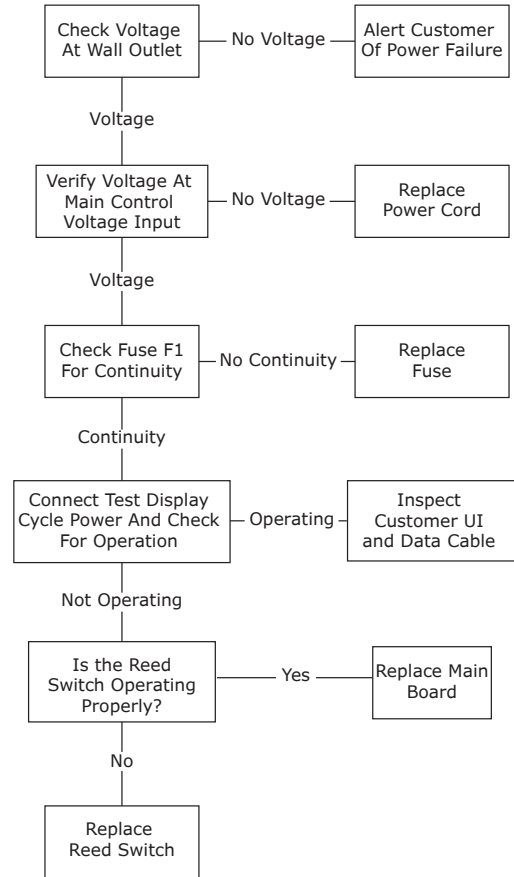

TROUBLESHOOTING GUIDE (see Appendix)

Concern	Potential Causes	Action
No Display or Interior Lights	Unit may be in Sabbath mode	<ul style="list-style-type: none"> Hold  for 5 seconds to turn off Sabbath mode, test the door switch circuit Unplug unit, wait 5 seconds, plug back in. If main board does not beep, check for 120V at black and white cables on power cord.
No Interior Light	Light may be set to OFF Check LED strip for power Defective door switch	Use component testing in service mode and test light circuit, manually test door switch
Condensation on exterior of unit	Is unit exposed to high humidity or high ambient temps?	Moisture will dissipate as ambient temp. and humidity levels fall.
No Ice Production	Is the unit getting water?	Go to component testing and turn on fill valve and verify 120V at the valve.
Low Ice Production	Dirty condenser, faulty bin thermistor	Clean the condenser coil if needed, check bin thermistor reading in service mode.
Alert light flashing	Check error log	View errors in service mode, review error and take corrective action to resolve
Ice is too dense/ not dense enough	Water starvation Dirty evaporator	Check water supply Run a clean cycle Adjust ice thickness
Standing Water in Ice Bin	Drain hose is restricted, debris in bin drain hole, failed drain pump, failed dump valve	Make sure drain hose run is as straight as possible. Remove any kinks or tight bends.

Relay & DC Outputs

One of the primary functions of the main control is to operate the multiple relay and DC outputs during each cycle. Verify proper operation of these relays using the following procedure.

1. Enter "Component Toggle" through the service menu.

NOTICE

Frequently toggling the compressor relay could force the compressor into overload. The compressor will automatically deactivate during an overload and will remain deactivated until the overload switch cools. This could take some time. It is important to allow the compressor at least 5 minutes off time between relay cycles.

2. Toggle the desired relay. (Refer to Control Operation for complete relay list) Its related component should activate / deactivate with the switching of the relay. If it does not, test component

Other Suspected Main Control Faults

If other components have been ruled out as being faulty, but the unit continues to have operating issues, it is most likely due to a configuration error. Some configuration errors can be cleared by restoring the unit to its factory default setting. Factory defaults may be restored through the service menu. If that does not work, check that the board is programmed to the correct model in the service menu.

CAUTION

Precautions must be taken while working with live electrical equipment. Be sure to follow proper safety procedures while performing tests on live systems.

PLUNGER SWITCH

A plunger switch is used to monitor door state. When the door is closed it comes into contact with the plunger which closes a circuit which turns the light and display off. When the door is open the plunger moves outward and opens the circuit. If the door is left open for longer than 5 minutes the switch will trigger an error code and set an audible warning.

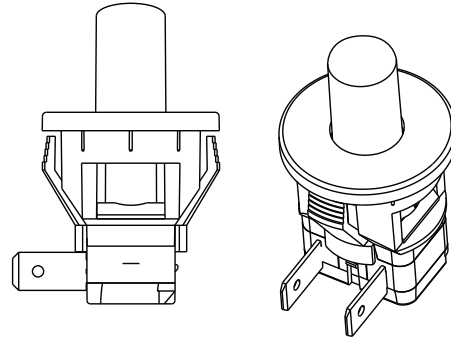

ERROR CODES

*All errors are logged in memory.

*Only door error is displayed on the display and has an audible signal.

E1: Thermistor 1 open.

E2: Thermistor 2 open.

E3: Thermistor 3 open.

E4: Thermistor 4 open.

E5: Thermistor 1 shorted.

E6: Thermistor 2 shorted.

E7: Thermistor 3 shorted.

E8: Thermistor 4 shorted.

E9: Door 1 open error.

E10: (displayed as 10): Door 2 open

*E11: (displayed as 11): Water level (tray or reservoir) high.

*E12: (displayed as 12): Water level low.

*E13: Unit not calling for water

*P1: Pump circuit open

*Ice Level Issues

* See APPENDIX on following pages

APPENDIX

E11: Sensor in base near fan detecting water

This sensor is designed to detect water escaping the product due to any type of malfunction inside the machine. Once activated, the only way to reset this error is to completely dry the two probes and cycle power to the machine via the rocker switch or power cord. Once power is cycled, it will take 20 minutes to reactivate the error code. Only the drain pump will retain power and be able to activate under this condition.

Inspect the entire base area in front and behind the sensors.

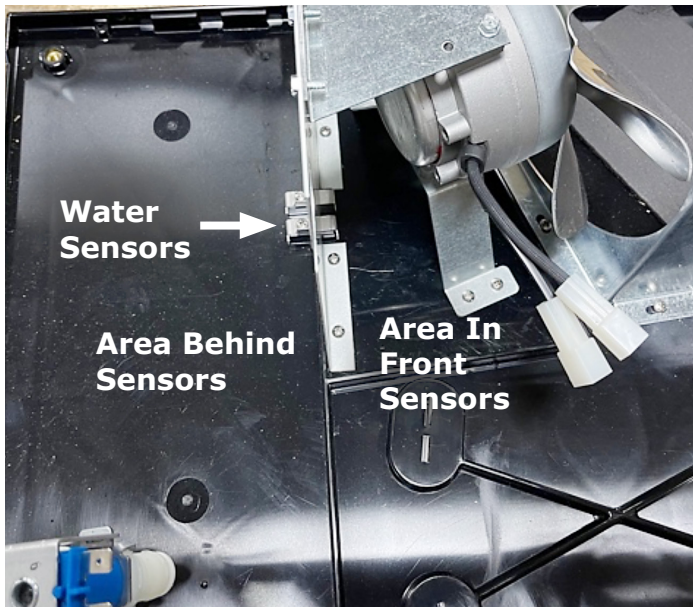

1. If the unit is equipped with a drainage pump, inspect it for leaks - check connections.
2. Remove pump and check all connections on water valves, water supply, and drain.
3. Check bolt on water reservoir. If loose, it may leak during a clean cycle when reservoir is filled to the top. Torque Spec. is 16 in-lbs.
4. Check areas around ice maker auger on both ends. If any leakage is evident, it is likely poor water quality and/or failure to clean is the cause.
 - a. Check TDS (see WATER HOOK UP section) - if outside tolerance, please report to factory and advise homeowner that repairs cannot be made to unit until water quality issue is resolved. Filters available at u-line.com are able to treat TDS up to 600.*

- b. If TDS is acceptable, unit must be cleaned and any leakage addressed with a seal kit. (U-Line service part # 80-55371-13)

***SEE "WATER HOOKUP" SECTION FOR SPECIFIC INFORMATION REGARDING TDS LEVELS**

Area in Front of Sensors (Condenser Side) is Wet

- Check connection from bin to drain.

No Water is Evident

1. Power cycle to reset error
2. Check sensors to ensure there is a gap between sensors and pan as shown.
3. If error persists, check wiring to sensors for a short.

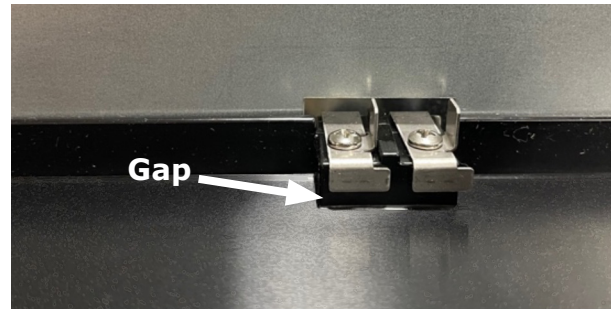

E12: Float switch in reservoir not rising

This error is designed to ensure sufficient water exists to produce ice, thus preventing permanent damage to the module. In order for this error to occur, the ice-making sequence must initiate two tries to fill the reservoir. This may take an hour or more to generate the error code.

Steps to check and correct - remember it is necessary to power cycle after making the corrections.

1. Check incoming water supply to ensure it is turned on and has sufficient pressure.
2. Verify water filter (if applicable) is in place and has been replaced on schedule.
3. If unit is a 1 Class product, enter service mode and activate relay 4 to determine if unit fills with water.
 - a. If it does not fill, check water valve for power during sequence.
 - If there is power, check valve resistance to determine if coil is shorted.
 - Check valve to ensure it is not blocked with debris.

- b. If unit fills, the float switch is malfunctioning and needs to be replaced (part # 80-55538-00).
4. If unit is 3 Class product, enter service mode and activate relays 1 and 4 to determine if unit fills with water.
 - a. If it does not fill, check water valve for power during sequence.
 - If there is power, check valve resistance to determine if coil is shorted.
 - Check valve to ensure it is not blocked with debris.
 - b. If unit fills, the float switch is malfunctioning and needs to be replaced (part # 80-55538-00).

E13: Float switch in reservoir not dropping quickly enough

This error is designed to detect insufficient ice product due to overheating or poor water quality. Failure to address this error can cause permanent damage not covered under warranty. The user may notice deteriorating ice quality prior to the error.

Steps to check and correct - remember it is necessary to power cycle after making the corrections.

1. Ice is slushy and user noticed deterioration in quality prior to the error.
 - a. Check condenser and toe kick. Fan must be operating and clear of debris.
 - b. Check TDS level. (see WATER HOOK UP section) High levels of TDS will result in this error.
2. In more severe conditions, not covered above, the unit may run up to an hour prior to generating this error, resulting in very slushy ice or no ice production at all.*
 - a. High TDS. High TDS restricts ability to produce ice and causes excessive buildup of minerals on the ice-making mechanism. A single cleaning may not resolve this condition.
 - b. General cleaning has not been performed. A single cleaning may not resolve this condition.
 - c. If customer has unit connected to a water softener, have them consult a plumber to disconnect from the softener.

***SEE "WATER HOOKUP" SECTION FOR SPECIFIC INFORMATION REGARDING TDS LEVELS**

- d. Check compressor operation.
 - If unit is not cooling or compressor is not operating, diagnose and fix system problem.
 - If unit is cooling, check auger for rotation. If not rotating, check the motor and electrical connections to auger.
3. If the ice has been solid and appears solid after a power cycle check it is possible the float switch is not operating properly and should be replaced.

P1: Drain related error

This error is designed to prevent water related issues due to a failure of the unit to drain water. In most cases this error is not related to the unit and related to improper installation or restriction of the drain line.

1. If the unit does not have a drain pump this error is generated by a missing jumper on the power harness. Inspect and install jumper.
2. If the unit does have a drain pump.
 - a. Check the installation to ensure the drain line is not restricted leaving the unit.
 - b. Inspect the drain pump to determine if the motor is operating. A slight noise should be heard if the pump is full of water.

Ice Level Issues

If there is a complaint regarding the unit filling too full with ice.

1. Check the thermistor to ensure it is installed properly and any holes through the rear of cabinet are completely sealed with sealing compound. Warm air that can make its way to the thermistor will give improper readings and cause the bin to overfill.
2. The bin thermistor offset may be changed via service mode option #5. Be careful to adjust in small increments to suit customer preferences.

Control Operation-Service

UI BUTTON LAYOUT

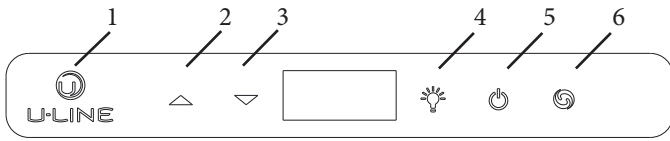

1. **Hidden Button**
 -Access Service Menu
 -No LED directly above. All LEDs turn on with button

2. **Up Button**
 -Increases temperature
 -Navigates through service menu

3. **Down Button**
 -Decreases temperature
 -Navigates through service menu

4. **Light Button**
 -Activates light for 3 hours on select models
 -Used to select items in service menu

5. **Power Button**
 -Turns unit off/on

6. **Clean Button**
 -Activates Clean Cycle on select models

CONTROL FUNCTION GUIDE

FUNCTION	COMMAND	DISPLAY/OPTIONS
ON/OFF	Press and release	Unit will immediately turn ON or OFF
Sabbath Mode	See "Sabbath Mode" section	
Silent Mode (ice production suspended for 3 hours)	Hold and	Display will show "3H"
Clean Mode	See "Cleaning" section	

SILENT MODE

In some cases it may be requested for the unit to be shut down temporarily - during meetings for example. To do this, hold the and for three seconds. The unit will "beep" once and show 3H on the display. This mode can be canceled by pressing and releasing . The mode will automatically be changed back to ON after three hours.

SHOWROOM MODE

This mode is designed to show units in a display environment. When in this mode the only functions will be the control and cabinet lights. The compressor, fans, etc. will not operate. To enter/exit this mode hold the light key and the power key for 5 seconds. The display will flash once and beep and the degree symbol will begin to flash. When the degree symbol is flashing the unit will allow the use of the control for demonstrations. The unit can be left in this mode indefinitely.

SERVICE MODE

This mode has options available for service diagnostics. To enter the mode hold the hidden key for 10 seconds. The display will show "0." When in this mode use the up and down arrows to select the desired option. The LIGHT key is the ENTER key and will initiate the function. If changing a setting, you must press the LIGHT key again to retain the changed setting. To exit the service mode scroll to option "0" and press the LIGHT key. After five minutes of not touching any keys the mode will also exit automatically.

SERVICE MODE GUIDE

0. Exit
1. Thermistor 1 temperature not including offsets.
2. Thermistor 2 temperature not including offsets.
3. Thermistor 3 temperature not including offsets.
4. Thermistor 4 temperature not including offsets.
5. Thermistor 1 offset. (+/- 10)
6. Thermistor 2 offset. (+/- 10)
7. Thermistor 3 offset. (+/- 10)
8. Thermistor 4 offset. (+/- 10)
9. Thermistor 2 set point
10. Thermistor 3 set point.
11. Thermistor 4 set point.
12. Defrost Interval (0 to 99 hr)
13. Defrost duration (0 to 99 min)
14. Error Log (See Appx D)
15. Clear error log (hold light key until cleared)
16. Thermistor 1 differential (+5)
17. Thermistor 3 differential (+5)
18. Evaporator fan on delay (0 to 99 sec)
19. Evaporator fan off delay (0 to 99 sec)
20. Individual component toggle
 - Option #0 - Exit
 - Option #1 - Relay 1
 - Option #2 - Relay 2
 - Option #3 - Relay 3
 - Option #4 - Relay 4
 - Option #5 - Relay 5
 - Option #6 - Relay 6
 - Option #7 - DC Output 1
 - Option #8 - DC Output 2
 - Option #9 - DC Output 3
 - Option #10 - DC Output 4
 - Option #11 - DC Output 5
 - Option #12 - Serial output (Compressor)
21. Model number
22. Light All Segments
23. Activate Defrost/Harvest- press and hold for 3 seconds to activate defrost/harvest
24. Defaults- press and hold for 3 seconds to restore all values to factory defaults.
25. Main Software (Display only)
26. Live Log Period (frequency that data is output to diagnostics port)
27. Factory test mode (0=Off, 1=On)
28. Compressor RPM
29. Freeze time adjust (Model 54 only)
30. Harvest time adjust (Model 54 only)
31. Low temp alarm limit (Model 55 only)
32. High temp alarm limit (Model 55 only)

SERVICE MODE GUIDE

1. **THERMISTOR 1 - BIN**

This shows the pure thermistor reading with no offsets taken into account.
2. Does not apply to this model
3. Does not apply to this model
4. Does not apply to this model
5. **THERMISTOR 1 - OFFSET**

Offset controls the amount of ice in bin
Range: -10 to +10 Higher value = more ice
6. **THERMISTOR 2 - OFFSET**

This shows the pure thermistor reading with no offsets taken into account.
7. Does not apply to this model
8. Does not apply to this model
9. Does not apply to this model
10. Does not apply to this model
11. Does not apply to this model
12. Does not apply to this model
13. Does not apply to this model
14. **VIEW ERROR LOG**

E1: Thermistor 1 open.
E2: Thermistor 2 open.
E3: Thermistor 3 open.
E4: Thermistor 4 open.
E5: Thermistor 1 shorted.
E6: Thermistor 2 shorted.
E7: Thermistor 3 shorted.
E8: Thermistor 4 shorted.
E9: Door 1 open error.
E10: (displayed as 10): Door 2 open
E11: (displayed as 11): Water level (tray or reservoir) high. Generates service notice in app (Not producing enough ice to empty the reservoir)
E12: (displayed as 12): Water level low. Generates service notice in app (Not getting enough water into the reservoir)
E13: Auger error
P1: Pump Circuit open Generates service notice in app (restricted drain line or failed drain pump)

15. CLEAR ERROR LOG

To clear errors, press and hold  (5 seconds) when CLR is flashing.

16. THERMISTOR - 1 DIFFERENTIAL

This number should not be adjusted

17. Does not apply to this model

18. Does not apply to this model

19. Does not apply to this model

20. INDIVIDUAL COMPONENT TOGGLE

Display #	Relay / Output
-----------	----------------

- Option #0 - Exit
- Option #1 - Relay 1
- Option #2 - Relay 2
- Option #3 - Relay 3
- Option #4 - Relay 4
- Option #5 - Relay 5
- Option #6 - Relay 6
- Option #7 - DC Output 1
- Option #8 - DC Output 2
- Option #9 - DC Output 3
- Option #10 - DC Output 4
- Option #11 - DC Output 5
- Option #12 - Serial output (Compressor)

SEE RELAY / OUTPUT CHART

21. MODEL NUMBER INDICATOR

Displays the two-digit model number of the specific unit. See Model list table.

22. LIGHT ALL LED SEGMENTS

This will illuminate all the LEDs on the display to ensure they work properly

23. ACTIVATE DEFROST /HARVEST

-Press and hold for 3 seconds to activate

24. FACTORY DEFAULTS

-Press and hold for 3 seconds to restore all values to factory defaults

25. MAIN SOFTWARE

26. Does not apply to this model

27. FACTORY TEST MODEL

0 = Off, 1 = On

28. COMPRESSOR RPM

29. FREEZE TIME ADJUST (MODEL 54 ONLY)

30. HARVEST TIME ADJUST (MODEL 54 ONLY)

31. LOW TEMP ALARM LIMIT (MODEL 55 ONLY)

32. HIGH TEMP ALARM LIMIT (MODEL 55 ONLY)

Relay / Output Chart

Program	Model	Relay 1	Relay 2	Relay 3	Relay 4	Relay 5	Relay 6	DC1	DC2	DC3	DC4	DC5
53	Nugget Ice, 1 Class	Comp/Fan	-	Dump Valve	Reservoir Fill	Auger	Water Main	Light 1	Light 2	-	-	Cond Fan
57	Nugget Ice, 3 Class	Water Main	Water Dis-pense	Dump Valve	Reservoir Fill	Auger	Cond Fan	Light 1	Light 2	-	-	Cond Fan
11	Clear Ice, 3 Class	Compressor	Water Dis-pense	Circ Pump	Water Inlet	Hot Gas Valve	Cond Fan	Light 1	Light 2	-	-	Cond Fan
01	**BV315-***1A	Compressor	-	-	-	-	-	Light 1	Light 2	Evap Fan	-	Cond Fan
03	**BV318-***1A	Compressor	-	-	-	-	-	Light 1	Light 2	Evap Fan	-	Cond Fan
04	**BV324-***1A	Compressor	-	-	-	-	-	Light 1	Light 2	Evap Fan	-	Cond Fan
06	**BV336-***1A	Compressor	Top/Left Valve	Bot/Right Valve	-	-	-	Light 1	Light 2	Evap Fan	Evap Fan 2	Cond Fan
07	**BV515-***1A	Compressor	-	-	-	-	-	Light 1	Light 2	Evap Fan	-	Cond Fan
09	**BV524-***1A	Compressor	-	-	-	-	-	Light 1	Light 2	Evap Fan	-	Cond Fan
13	**DR324-***1A	Compressor	Mullion Heater	-	-	-	-	Light 1	Light 2	Evap Fan	Evap Fan 2	Cond Fan
15	**FZ124-***1A	Compressor	-	-	-	Heater	Cond Fan	Light 1	Light 2	Evap Fan	-	Cond Fan
17	**RE315-***1A	Compressor	-	-	-	-	-	Light 1	Light 2	Evap Fan	-	Cond Fan
19	**RE318-***1A	Compressor	-	-	-	-	-	Light 1	Light 2	Evap Fan	-	Cond Fan
20	**RE324-***1A	Compressor	-	-	-	-	-	Light 1	Light 2	Evap Fan	-	Cond Fan
22	**RE336-***1A	Compressor	Top/Left Valve	Bot/Right Valve	-	-	-	Light 1	Light 2	Evap Fan	Evap Fan 2	Cond Fan
23	**RE515-***1A	Compressor	-	-	-	-	-	Light 1	Light 2	Evap Fan	-	Cond Fan
25	**RE524-***1A	Compressor	-	-	-	-	-	Light 1	Light 2	Evap Fan	-	Cond Fan
27	**RE324-***1A	Compressor	-	-	-	-	-	Light 1	Light 2	Evap Fan	-	Cond Fan
29	**KR524-***1A	Compressor	-	-	-	-	-	Light 1	Light 2	Evap Fan	-	Cond Fan
32	**WC315-***1A	Compressor	-	-	-	-	-	Light 1	Light 2	Evap Fan	-	Cond Fan
33	**WC318-***1A	Compressor	-	-	-	-	-	Light 1	Light 2	Evap Fan	-	Cond Fan
35	**WC324-***1A	Compressor	-	-	-	-	-	Light 1	Light 2	Evap Fan	-	Cond Fan
37	**WC515-***1A	Compressor	-	-	-	-	-	Light 1	Light 2	Evap Fan	-	Cond Fan
38	**WC524-***1A	Compressor	-	-	-	-	-	Light 1	Light 2	Evap Fan	-	Cond Fan
40	**WC336-***1A	Compressor	Top/Left Valve	Bot/Right Valve	-	-	-	Light 1	Light 2	Evap Fan	Evap Fan 2	Cond Fan
41	**BD324-***1A	Compressor	Top/Left Valve	Bot/Right Valve	-	-	-	Light 1	Light 2	Evap Fan	Evap Fan 2	Cond Fan
43	**BD524-***1A	Compressor	Top/Left Valve	Bot/Right Valve	-	-	-	Light 1	Light 2	Evap Fan	Evap Fan 2	Cond Fan
46	**WD324-***1A	Compressor	Top/Left Valve	Bot/Right Valve	-	-	-	Light 1	Light 2	Evap Fan	Evap Fan 2	Cond Fan
48	**WD524-***1A	Compressor	Top/Left Valve	Bot/Right Valve	-	-	-	Light 1	Light 2	Evap Fan	Evap Fan 2	Cond Fan
50	**RF124-***1A	Compressor	-	-	Pan	Defrost Heater	Cond Fan	Light 1	Light 2	Evap Fan	-	Cond Fan
52	**RI124-***1A	Compressor	Ice maker 2	Ice maker 1	Pan	Defrost Heater	Cond Fan	Light 1	Light 2	Evap Fan	-	Cond Fan

Thermistor

Thermistors are used for various temperature readings. Thermistors provide reliable temperature readings using a resistance which varies based on surrounding temperatures. If a faulty thermistor is suspected, it may be tested using an accurate ohmmeter.

Thermistor connections must be kept clean. A thermistor connection that has become corroded can cause resistance values from the thermistor to change as they pass through a dirty connection to the board.

It is for that reason that we apply dielectric grease to all of our thermistor connections. Dielectric grease will help to keep thermistor connections clean and dry.

If you change a thermistor in the unit, please re-apply dielectric grease to the connection. If you encounter a dirty thermistor connection, you should replace the thermistor and the thermistor harness.

This unit has one thermistor located along the right hand sidewall of the ice bin. It is used to maintain the ice level in the bin.

Thermistor Resistance Data

Temp (F)	Temp (C)	Nominal Resistance (OHMS)*
-40	-40	169157
-31	-35	121795
-22	-30	88766
-13	-25	65333
-4	-20	48614
5	-15	36503
14	-10	27681
23	-5	2116
32	0	16330
41	5	12696
50	10	9951
59	15	7855
68	20	6246
77	25	5000
86	30	4029
95	35	3266
104	40	2665
113	45	2186
122	50	1803
131	55	1495
140	60	1247
149	65	1044
158	70	879
167	75	743
176	80	631

* (+/- 5%)

U-Line Corporation (U-Line) Limited Warranty

One Year Limited Warranty

For one year from the date of original purchase, this warranty covers all parts and labor to repair or replace any part of the product that proves to be defective in materials or workmanship. For products installed and used for normal residential use, material cosmetic defects are included in this warranty, with coverage limited to 60 days from the date of original purchase. All service provided by U-Line under the above warranty must be performed by a U-Line factory authorized servicer, unless otherwise specified by U-Line. Service provided during normal business hours.

Two Year Limited Warranty (5 Class Product)

For two years from the date of original purchase, this warranty covers all parts and labor to repair or replace any part of the product that proves to be defective in materials or workmanship. For products installed and used for normal residential use, material cosmetic defects are included in this warranty, with coverage limited to 60 days from the date of original purchase. All service provided by U-Line under the above warranty must be performed by a U-Line factory authorized servicer, unless otherwise specified by U-Line. Service provided during normal business hours.

Available Second & Third Year Limited Warranty

In addition to the standard one and two year warranties outlined above, U-Line offers a one year extension of the warranties from the date of purchase, free of charge. To take advantage of this extension, you must register your product with U-Line within 60 days from the date of purchase at u-line.com and provide proof of purchase. Nugget Ice Machine proof of purchase must include the purchase of an in-line water filter and filter head to qualify for this additional limited warranty.

Five Year Sealed System Limited Warranty

For five years from the date of original purchase, U-Line will repair or replace the following parts, labor not included, that prove to be defective in materials or workmanship: compressor, condenser, evaporator, drier, and all connecting tubing. All service provided by U-Line under the above warranty must be performed by a U-Line factory authorized servicer, unless otherwise specified by U-Line. Service provided during normal business hours.

Terms

These warranties apply only to products installed in any one of the fifty states of the United States, the District of Columbia, or the ten provinces of Canada. The warranties do not cover any parts or labor to correct any defect caused by negligence, accident or improper use, maintenance, installation, service, repair, acts of God, fire, flood or other natural disasters. The product must be installed, operated, and maintained in accordance with your product's User Guide.

The remedies described above for each warranty are the only ones that U-Line will provide, either under these warranties or under any warranty arising by operation of law. U-Line will not be responsible for any consequential or incidental damages arising from the breach of these warranties or any other warranty, whether express, implied, or statutory. Some states do not allow the exclusion or limitation of incidental or consequential damages, so the above limitation or exclusion may not apply to you. These warranties give you specific legal rights, and you may also have other rights which vary from state to state.

Any warranty that may be implied in connection with your purchase or use of the product, including any warranty of *merchantability* or any warranty *fit for a particular purpose* is limited to the duration of these warranties, and only extends to five years in duration for the parts described in the section related to the five year limited warranty above. Some states do not allow limitations on how long an implied warranty lasts, so the above limitations may not apply to you.

- The warranties only apply to the original purchaser and are non-transferable.
- The second, third, and five year warranties cover products installed and used for normal residential or designated marine use only.
- The warranties apply to units operated outside only if designed for outdoor use by model and serial number.
- U-Line Commercial products are covered by the one year and 5 year limited warranties and are not eligible for the second and third year limited warranties.
- Replacement water filters, light bulbs, and other consumable parts are not covered by these warranties.
- The start of U-Line's obligation is limited to four years after the shipment date from U-Line.
- In-home instruction on how to use your product is not covered by these warranties.
- Food, beverage, and medicine loss are not covered by these warranties.
- If the product is located in an area where U-Line factory authorized service is not available, you may be responsible for a trip charge or you may be required to bring the product to a U-Line factory authorized service location at your own cost and expense.
- Units purchased after use as floor displays, and/or certified reconditioned units, are covered by the limited one year warranty only and no coverage is provided for cosmetic defects.
- Signal issues related to Wi-Fi connectivity are not covered by these warranties.

For parts and service assistance, or to find U-Line factory authorized service near you, contact U-Line:
8900 N. 55th Street, Milwaukee, WI 53223 • u-line.com • onlineservice@u-line.com • +1.414.354.0300