



UNDERCOUNTER BEVERAGE CENTERS

15"W. VUBV515GSS and 24"W. VUBV524GSS

FEATURES

- Storage Capacity
 - 15"W. model:
 - Volume of 2.9 cu. ft. holds up to 8 wine bottles (750ml) and 34 bottles (12 oz.) or 54 cans (12 oz.)
 - 24"W. model:
 - Volume of 5.2 cu. ft. holds up to 14 wine bottles (750ml) and 68 bottles (12 oz.) or 111 cans (12 oz.)
- Full-depth lower interior maximizes storage options
- Variable speed compressor delivers maximum energy efficiency, faster temperature response, and quieter operation
- Convection cooling system provides a quick cool down and consistent temperature
- Temperature range: 33°F – 70°F
- Stainless steel interior
- Stainless steel cabinet, toe kick, and accents
- Easy adjusting interior with 19 adjustable positions
- Two removable, full-extension easy to load bins
- Two removable, full-extension wine racks
- Digital touch pad control with blue LED display
- Adjustable bright white or blue LED lighting
- Soft close door with articulating hinge
- Field reversible door is shipped right-hand hinged
- Built-in or freestanding
- Four adjustable leveling legs

MODEL NUMBERS

- VUBV515GSS – 15"W. Refrigerated Beverage Center
- VUBV524GSS – 24"W. Refrigerated Beverage Center

DESIGN OPTIONS

- Product ships as right hinge; field reversible

COLOR FINISHES

- Available in Stainless Steel (SS)



WARRANTY

- 2-year full covers complete unit
- 6-year full – sealed refrigeration system
- 90-day full – cosmetic parts such as glass, painted items, and decorative items
- 12-year limited – sealed refrigeration system



UNDERCOUNTER BEVERAGE CENTER		
MODEL	VUBV515GSS	VUBV524GSS
Amps: Running	1.2	
Capacity: Bottle (12 oz)	34	68
Capacity: Can (12 oz)	54	111
Capacity Volume (cu ft)	2.9	5.2
Capacity: Wine Bottle (750 ml)	8	14
Dimensions: Product Depth	22 15/16" (583 mm)	
Dimensions: Product Height (Min.)	33 11/16" (855 mm)	
Dimensions: Product Width	14 15/16" (379 mm)	23 5/8" (600 mm)
Energy Consumption: Avg. Per Year	285 kWh	305 kWh
ENERGY STAR (glass door)	No	
Refrigerant Type:	R600a	
Sabbath (Star K Certified)	Yes	
Temperature Range	33°F – 70°F	
Voltage	115/60	
Weight	105 lb.	163 lb.

Please do not prepare installation from brochure data only. See installation instructions for important clearance/installation information.



UNDERCOUNTER BEVERAGE CENTERS

15"W. VUBV515GSS and 24"W. VUBV524GSS

FRONT

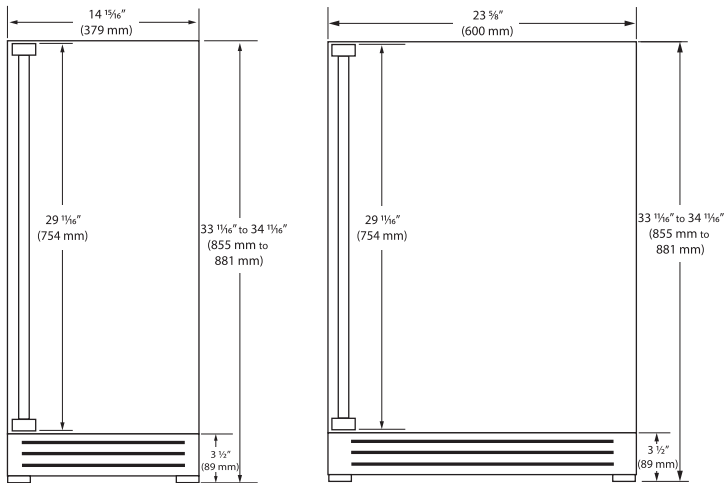

TOP

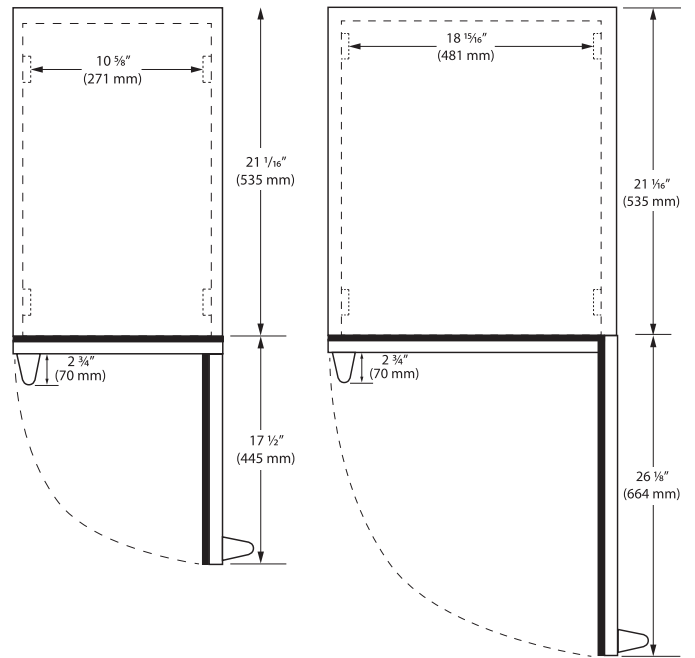

SIDE

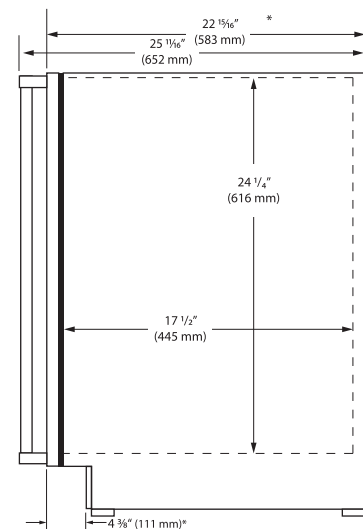

CUTOUT

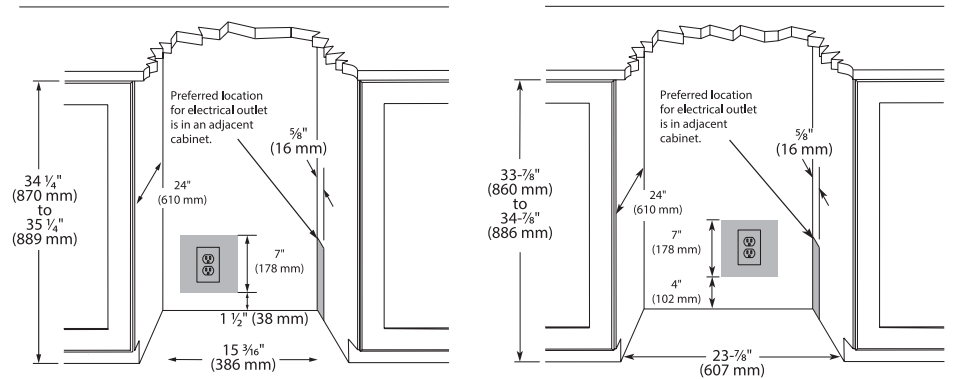

REAR

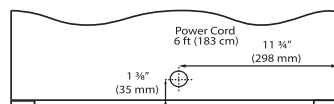
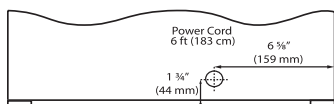

VIKING RANGE, LLC 111 FRONT STREET GREENWOOD, MISSISSIPPI 38930 USA

For detailed product information, model numbers, or to request a quote call 1-888-845-4641 or visit vikingrange.com
 © 2020 Viking Range, LLC All rights reserved. Specifications subject to change without notice.